

Development of  
Information Support Solutions  
for Complex Technical Systems  
using eMaintenance

Olov Candell



**Development of  
Information Support Solutions  
for Complex Technical Systems  
using eMaintenance**

**Olov Candell**

Luleå University of Technology  
Division of Operation and Maintenance Engineering

Printed by Universitetstryckeriet, Luleå 2009

ISSN: 1402-1544

ISBN 978-91-7439-030-8

Luleå 2009

[www.ltu.se](http://www.ltu.se)

## **Acknowledgements**

This research has been carried out at the Division of Operation & Maintenance Engineering at Luleå University of Technology (LTU). The author would like to acknowledge the financial support of the Swedish National Aeronautics Research Programme (NFFP), Saab Aerotech and Saab Aerosystems. The activities in this research have been managed through a joint industrial and academic project, and have been supported by many people in different ways.

The ILS Development Department, Aircraft Services Division at Saab Aerotech has together with individuals at other divisions at Saab Aerotech, Saab Aerosystems, the Swedish Air Force Wing F21 and the Swedish Defence Materiel Administration (FMV), contributed to the NFFP projects and participated in workshops as well as provided valuable information for the study.

First of all, I wish to express my sincere thanks to my main supervisor Professor Uday Kumar and co-supervisors Assistant Professor Ramin Karim and Assistant Professor Peter Söderholm, who have guided, supported and encouraged me during my studies. I would also like to thank Professor Per Anders Akersten and Professor Bengt Klefsjö for valued supervision during my first years as a Ph.D. student. At the Division of Operation & Maintenance Engineering I also owe thanks to Lic. Eng. Alireza Ahmadi, Dr Mattias Holmgren and Dr Aditya Parida, and all other colleagues, for interesting discussions. They have all made me feel welcome during my working sessions at LTU.

During the work with this thesis I have received most valuable support in different ways from many of my colleagues at Saab Aerotech and Saab Aerosystems. The original ideas for the NFFP research were worked out together with Carl-Johan Wilén and Per Nilsson, who also encouraged me to take on the challenge of a 'mid life-upgrade' as a Ph.D. student. Elisabeth Jaksic, Mats Hultin and Kjell Karlsson supported the ideas and made it possible to combine ordinary work with the NFFP-programme and Ph.D. studies. Leif Gyllström introduced me to Product Life Cycle Support (PLCS) and stimulated innovative thinking about data and information. Mårten Szymanowski provided cognitive perspectives and much-needed sparring. Joakim Rylander, Claes Wadsten and Lars Sjöström contributed significantly by promoting Operation & Maintenance R&D. Göran Bengtsson and Katarina Björklund have, through excellent management of the NFFP programme at Saab, provided the best circumstances for implementation of the research project. Thanks also to Lt. Col. Laci Bonivart and Hans Öhlund at SwAF Wing F21, Jan Johansson

## *Acknowledgements*

FMV and all my other colleagues at Saab Aerotech, who all shared their knowledge as experienced aviation maintenance professionals. I would also like to thank Gary Watson who has helped me to improve the English of this thesis. At Saab Aerotech Wanja Strömberg has provided most valuable administrative help, and at LTU Marie Fjällström has done likewise.

Finally, and above all, I would like to thank my family. Their support made my Ph.D. studies possible. A long time has passed since my mother, father and elder brother helped me to realize how much fun and rewarding it is to be curious and to keep on learning new things. Thanks to the inspiration and motivation from my beloved daughters Klara, Lisa and Ebba, and the encouragement from all who are close to me, it has been possible to finally reach the goal for this thesis work.

Olov Candell

Kisa, Oktober 2009

## Abstract

Deployment and use of complex technical systems are common in society and in industry. Many of the complex technical systems have stringent requirements on safety, dependability and cost, which necessitate frequent updates and modification in response to new developments in technology and changing functional requirements. Hence, correct, role-adapted, situation-adapted, context-adapted and timely information and information support, are crucial to be able to access, manage, maintain and improve the services these systems are required to provide. Given the technological development and the changing business environment, system and support providers need to improve the design and provision of information support solutions. This can be facilitated by the utilisation of new and innovative Information & Communication Technology (ICT), manifested in emerging approaches such as eMaintenance. However, there is still a need for methodologies and tools that enable the development and provision of support information services by integrating business and maintenance processes at both customers and providers to achieve novel business solutions such as Performance-Based Logistics (PBL) in the context described above.

Hence, the purpose of this research is to describe how providers of support solutions can develop and provide effective information support solutions related to complex technical systems by enhanced utilisation of ICT. To fulfil this purpose, a single case study within military aviation was performed. Empirical data were collected through interviews, observations, archival records, workshops and action research. The analysis was based on existing, adapted and developed theories, model-based simulations and available international standards.

The results of the research are: I) a definition of system-oriented, service-oriented, process-oriented and lifecycle oriented eMaintenance solutions; II) an identification of critical information and information support requirements of customers and providers while implementing e-maintenance; III) an identification of ICT-related methodologies and technologies suitable to fulfil the information support requirements of customers and providers; and IV) an approach for development and provision of ICT-based information support solutions that satisfy the requirements of customers and providers.

Even though these results are achieved within the context of a modern military aircraft, the results throughout the research process indicate that they to a large extent are generic in nature and can be applicable to other complex

technical systems within the process, power generation and transportation industries as well.

Keywords:

Maintenance process, Product support, Complex Technical System, Aviation Maintenance, Maintenance Support Services, eMaintenance, eMaintenance Framework, Service-Oriented, Process-Oriented, Information Logistics, Military Aircraft, System Life Cycle, Performance-Based Logistics (PBL), Information Support



## Summary in Swedish (Sammanfattning)

Spridningen och användningen av komplexa tekniska system är vanlig i samhället och inom industrin. Många av de komplexa tekniska systemen har stränga krav på säkerhet, tillförlitlighet och kostnader, vilket kräver frekventa uppdateringar och ändringar till följd av ny teknisk utveckling och förändrade funktionskrav. Därför är korrekt, kontextanpassad och aktuell information och informationsstöd avgörande för åtkomst, förvaltning, underhåll och förbättring av de kravställda tjänster som skall tillhandahållas av dessa system. Med tanke på den tekniska utvecklingen och det föränderliga företagsklimat, behöver system- och supportleverantörer förbättra utformning och tillhandahållande av lösningar för informationsstöd. Detta kan underlättas genom användning av ny och innovativ informations- och kommunikationsteknologi, (IKT) vilka manifesteras i nya angreppssätt såsom eMaintenance. Det finns dock fortfarande ett behov av arbetssätt och verktyg för utveckling och tillhandahållande av informationsstöd genom en integration av affärs- och underhållsprocesser hos både kunder och leverantörer, för att åstadkomma nya affärlösningar såsom Prestandabaserad Logistik (PBL) i de sammanhang som beskrivs ovan.

Syftet med denna forskning är därför för att beskriva hur leverantörer av supportlösningar kan utveckla och erbjuda effektiv informationsstöd kopplat till komplicerade tekniska system genom ökad användning av IKT. För att uppnå detta syfte, har en fallstudie inom militär luftfarten utförts. Empiriska data har samlats in genom intervjuer, observationer, arkivstudier, workshops och deltagande forskning. Analysen baseras på befintliga, anpassade och utvecklade teorier, modellbaserade simulering och tillgängliga internationella standarder.

Resultaten av forskningen är: I) en definition av service-, process- och livscykelorienterade eMaintenance lösningar, II) en identifiering av kunders och leverantörers kritiska krav på information och informationsstöd III) en identifiering av IKT-relaterade metoder och teknologier lämpade att uppfylla kunder och leverantörers krav på informationsstöd, IV) ett tillvägagångssätt för utveckling och tillhandahållande av IKT-baserade lösningar för informationsstöd som uppfyller kraven från kunder och leverantörer. Även om dessa resultat erhållits inom kontexten för ett modernt militärflygplan, indikerar resultat erhållna i forskningsprocessen att de i stor utsträckning är allmänna till sin karaktär och kan vara tillämpliga på andra komplexa tekniska system inom processindustrin, elproduktion och transportindustri.



## List of Appended Papers

- Paper I. Candell, O., Karim, R. and Söderholm, P. (2009). eMaintenance-Information logistics for maintenance support. *Journal of Robotics and Computer-Integrated Manufacturing*, vol. 25, issue 6. **(Published)**
- Paper II. Karim, R., Candell, O., and Söderholm, P. (2009). Development of ICT-based Maintenance Support Services. *Journal of Quality in Maintenance Engineering*, vol. 15, issue 2. **(Published)**
- Paper III. Karim, R., Candell, O., and Söderholm, P. (2009). E-maintenance and Information Logistics: Aspects of Content Format. *Journal of Quality in Maintenance Engineering*, vol. 15, issue 3. **(Published)**
- Paper IV. Söderholm, P., Karim, R. and Candell, O. (2008). *Design of Experiments and Simulation for Identification of Significant eMaintenance Services* **(Submitted to a journal)**
- Paper V. Candell, O., Karim, R., Söderholm, P. and Kumar , U. (2009). Service-oriented information logistics as support to intelligent transport services. *The 16<sup>th</sup> World Congress and Exhibition on Intelligent Transport Systems and Services*, 21st-25th September 2009, Stockholm, Sweden. **(Published)**
- Paper VI. Candell, O. and Karim, R. (2008). eMaintenance - Information Driven Maintenance and Support. *Proceedings of the 18<sup>th</sup> International Conference on Flexible Automation and Intelligent Manufacturing (FAIM 2008)*, 30<sup>th</sup> June - 2<sup>nd</sup> July 2008, Skövde, Sweden. **(Published)**



## List of Related Documentation

- Karim, R., Kajko-Mattsson, M., Söderholm, P., Candell, O., Tyrberg, T., Öhlund, H. and Johansson, J. (2008b). Positioning Embedded Software Maintenance within Industrial Maintenance. Proceedings of the 24<sup>th</sup> IEEE International Conference on Software Maintenance (ICSM), 28 September 2008, Beijing, China. **(Published)**
- Candell, O. (2004). *Development of User Information Products for Complex Technical Systems*. Licentiate thesis, Luleå University of Technology, Luleå, Sweden.
- Söderholm, P., Karim, R., Candell, O. and Kumar, U. (2009). Condition Monitoring and Maintenance Support Information Services. The Sixth International Conference on Condition Monitoring and Machinery Failure Prevention Technologies (CM2009), Dublin, Ireland. **(Published)**



## List of Definitions

<i>Term</i>	<i>Description</i>
Availability	The state of an item of being able to perform its required function (IEV, 2008).
Built-in Test	A built-in capability of the mission system or equipment, which provides a test capability to recognize and localize faults or deterioration of performance. (IEC 60706-5)
Dependability	A collective term that describes the availability performance and its influencing factors: reliability performance, maintainability performance and maintenance support performance. (IEV, 2008)
Effectiveness	The ability of an item to meet a service demand of given quantitative characteristics (IEV, 2008). Effectiveness is the accuracy and completeness with which specified users can achieve specified goals in particular environments.
Efficiency	The ratio of output power to input power of a device (IEV, 2008).
Enabling-system	A system that complements a system-of-interest during its life cycle stages but does not necessarily contribute directly to its function during operation. An enabling-system has a life cycle of its own. (ISO/IEC, 2008)
FLO	Flight Line Operations (FLO), at the technical centre of flight operations. Often outdoors in the vicinity of the runway, where aircrafts are made ready and finally checked for the sortie, and are received by an aircraft mechanic or aircraft technician after landing.
Framework	A meta-level model (a higher-level abstraction) through which a range of concepts, models, techniques, methodologies can either be clarified and/or integrated. (Jayaratna, 1994).
Maintainability	The probability that a given active maintenance action, for an item under given conditions of use can be carried out

	within a stated time interval, when the maintenance is performed under stated conditions and using stated procedures and resources (IEV, 2008).
Maintenance	The combination of all technical and administrative actions, including supervision actions, intended to retain an item in, or restore it to, a state in which it can perform a required function (IEV, 2008).
Maintenance plan	A detailed plan that specifies the methods and procedures which need to be followed for system support throughout its life cycle. (Blanchard, 2004)
Maintenance support	Resources required to maintain an item, under a given maintenance concept and guided by a maintenance policy. Resources include human resources, support equipment, materials and spare parts, maintenance facilities, documentation, information and maintenance information systems. (IEC, 2004)
Methodology	A set of principles of method which have to be reduced to method suitable for a specific situation (Checkland, 2007)
Performance Based Logistics (PBL)	Defines key system readiness and effectiveness criteria, and contract for threshold values of these criteria. The emphasis is on contracting for results and readiness levels, and not for resources (Kim et al., 2007)
Process	A complete set of interacting operations in a system by which matter, energy or information is transformed, transported or stored. From a time related perspective a process is a sequence of interrelated events. (IEV, 2008)
Product support	Can be defined as any form of assistance that companies offer to customers to help them gain maximum value from the manufactured products. It is commonly referred to as after-sales service, customer support, technical support, or simply as service. (Markeset, 2003). In literature customer support, after-sales support and product support are often used as synonyms.
Service	A set of functions offered to a user by an organization (IEV, 2008).



Service to support the product	Services to support the products can be defined as services needed to ensure a product's functional performance. These services are governed by the product's functional weaknesses. It includes support services such as maintenance, repairs, spare parts, expert advice, diagnostics, etc. (Markeset, 2003)
Services to support the customer	Services to support the customers can be defined as services intended to support the client's actions in relation to the product. They include services such as advanced training, performance analysis, operations and maintenance strategy development, etc. This kind of service is governed by customer's and manufacturer's knowledge, expertise, as well as their wants, needs, and preferences. (Markeset, 2003)
Swing-role-aircraft	Aircraft fully capable of combining different operational tasks in a single mission, e.g. both attack and reconnaissance.
System life cycle	The evolution with time of a system-of-interest from conception through to retirement of the system (ISO/IEC, 2008)
System-of-interest	The system which is under consideration in a context (ISO/IEC, 2008)
Usability	The extent to which a product can be used by specified users to achieve specified goals with effectiveness, efficiency and satisfaction in a specified context of use (ISO, 1998). Satisfaction refers to the comfort and acceptability of the work system to its users and other people affected by its use.



## List of Abbreviations

<i>Abbreviation</i>	<i>Full Form</i>
24/7	Twenty four hours a day, seven days a week.
4G	Fourth generation
A/C	Aircraft
ADL	Advanced Distributed Learning initiative
ASD	Aerospace and Defence Industries Association of Europe
BIT	Built-in Test
CBM	Condition-Based Maintenance
CLS	Contracted Logistic Support
DD	US Department of Defence
DoE	Design of Experiment
EDA	Event Driven Architecture
eMMF	eMaintenance Management Framework
eMMM	eMaintenance Management Model
eMP	eMaintenance Platform
eMSD	eMaintenance Service Development
EssUP	Essential Unified Process
FLO	Flight Line Operations
FMV	Försvarets Materielverk
GSE	Ground Support Equipment
HW	HardWare (any physical goods, e.g. an aircraft engine or a computer)
ICT	Information & Communications Technology

IEC	International Electrotechnical Commission
IEV	International Electrotechnical Vocabulary
ILS	Integrated Logistic Support
ISD	Information Service Development (Process)
JAS	Jakt Attack Spaning (Swedish), English; Fighter (air-to-air) Attack (air-to-ground) Reconnaissance.
KPI	Key Performance Indicator
LCC	Life Cycle Cost
LCM	Life Cycle Management
LSC	Life Support Cost
LRU	Line Replaceable Unit
LSA	Logistic Support Analysis
LSC	Life Support Cost
MIMOSA	Machinery Information Management Open System Alliance
MoD	UK Ministry of Defence
MSD	Maintenance Service Development
MTBF	Mean Time Between Failures
MTTF	Mean Time To Failure
NFF	No Fault Found
NFFP	National Aeronautic Research Programme
OM	Operational Monitoring
PBL	Performance Based Logistics
PDF	Portable Document Format
PHS&T	Packaging, Handling, Storage and Transportation

PLCS	Product Life Cycle Support
PNB	Probability of No Backorders
QFD	Quality Function Deployment
ROS	Risk Of Shortage
ROST	Risk Of Shortage with Time tolerance
RUP	Rational Unified Process
SAAB	Svenska Aeroaktiebolaget (Swedish)
SCORM	Sharable Content Object Reference Model
SOA	Service-Oriented Architecture
SRU	Shop Replaceable Unit
SW	SoftWare (a computer programme)
SwAF	Swedish Air Force
W3C	World Wide Web Consortium



## Table of Contents

<b>ACKNOWLEDGEMENTS</b> .....	<b>I</b>
<b>ABSTRACT</b> .....	<b>III</b>
<b>SUMMARY IN SWEDISH (SAMMANFATTNING)</b> .....	<b>V</b>
<b>LIST OF APPENDED PAPERS</b> .....	<b>VII</b>
<b>LIST OF RELATED DOCUMENTATION</b> .....	<b>IX</b>
<b>LIST OF DEFINITIONS</b> .....	<b>XI</b>
<b>LIST OF ABBREVIATIONS</b> .....	<b>XV</b>
<b>TABLE OF CONTENTS</b> .....	<b>XIX</b>
<b>1 INTRODUCTION AND BACKGROUND</b> .....	<b>1</b>
1.1 PURPOSE AND OBJECTIVES .....	6
1.2 RESEARCH QUESTIONS (RQ) .....	7
1.3 SCOPE AND LIMITATIONS .....	7
1.4 THESIS STRUCTURE .....	8
<b>2 THEORETICAL FRAMEWORK AND BASIC CONCEPTS</b> .....	<b>9</b>
2.1 SUPPORT SOLUTIONS FOR COMPLEX TECHNICAL SYSTEMS.....	9
2.2 DEPENDABILITY AND INTEGRATED LOGISTIC SUPPORT .....	13
2.3 MAINTENANCE AND MAINTENANCE SUPPORT.....	16
2.4 MAINTENANCE OF COMPLEX TECHNICAL SYSTEMS.....	18
2.5 INFORMATION .....	19
2.6 REQUIREMENTS AND QFD .....	20
2.7 eMAINTENANCE .....	23
<b>3 RESEARCH METHODOLOGY</b> .....	<b>27</b>
3.1 PURPOSE OF THE RESEARCH WORK.....	27
3.2 RESEARCH APPROACH.....	27
3.3 RESEARCH STRATEGY .....	29
3.4 DATA COLLECTION.....	31
3.5 RELIABILITY AND VALIDITY .....	35
<b>4 RESEARCH PROCESS</b> .....	<b>37</b>
4.1 PHASE 1: LITERATURE STUDY.....	38
4.2 PHASE 2: CASE STUDY.....	38
4.3 PHASE 3: CONCEPT DEVELOPMENT .....	39
4.4 PHASE 4: COMPILATION AND DISSEMINATION.....	39
4.5 OUTCOMES .....	40
<b>5 DESCRIPTION OF APPENDED PAPERS</b> .....	<b>41</b>

<b>6</b>	<b>DESCRIPTION OF CONCEPT DEVELOPMENT.....</b>	<b>45</b>
6.1	MAINTENANCE AND SUPPORT RELATED TO JAS39 GRIPEN.....	45
6.2	JAS39 GRIPEN AND INFORMATION SUPPORT .....	46
6.3	INFORMATION SUPPORT CONCEPT DEVELOPMENT .....	47
<b>7</b>	<b>RESULTS.....</b>	<b>59</b>
7.1	RESULT I RELATED TO RQ1 .....	59
7.2	RESULT II RELATED TO RQ1.....	60
7.3	RESULT III RELATED TO RQ2.....	64
7.4	RESULT IV RELATED TO RQ3 .....	65
<b>8</b>	<b>DISCUSSION.....</b>	<b>69</b>
8.1	DISCUSSION RELATED TO RQ 1.....	69
8.2	DISCUSSION RELATED TO RQ 2.....	71
8.3	DISCUSSION RELATED TO RQ 3.....	72
<b>9</b>	<b>CONCLUSIONS .....</b>	<b>75</b>
9.1	CONCLUSIONS RELATED TO RQ 1.....	75
9.2	CONCLUSIONS RELATED TO RQ 2.....	76
9.3	CONCLUSIONS RELATED TO RQ 3.....	77
9.4	RESEARCH CONTRIBUTION.....	78
<b>10</b>	<b>FURTHER RESEARCH.....</b>	<b>79</b>
	<b>REFERENCES .....</b>	<b>81</b>
	<b>APPENDED PAPERS .....</b>	<b>93</b>



*“The good news is that technology can make us smart. In fact, it already has.”*

*“The bad news is that technology can make us stupid. The technology for creating things has far outstripped our understanding of them.”*

Donald A. Norman.

*Things that make us smart: defending human attributes in the age of the machine. 2003.*



# 1 Introduction and Background

*This chapter provides background, introduction, purpose and objectives for this research. It also describes the research limitations and the stated research questions.*

Society is facing an ever increasing use and need of utilities such as energy, transportation, telecommunications and health-care. Utilities that have brought a growing attention from society and academy over the last decades (Winner, 1977; Bijker et al., 1987; Ingelstam, 1996).

The complexity of the systems which provide these utilities has reached unprecedented levels, with challenges following for the organisations that create and utilize them. At the same time, these complex systems<sup>1</sup> are used in environments that imply very high requirements on safety and credibility (Wachs, 2002; Graber, 2004; Bischoff, 2008).

These functional requirements and challenges exist throughout the lifecycle of a complex system. They arise from sources such as the inherent and structural differences between hardware (HW), software (SW) and human system elements, dependence on computer-based technologies and lack of harmonisation and integration of involved disciplines, including science, engineering, management and finance. (ISO/IEC, 2008).

As described above, society is dependent on the performance of complex systems-of-systems, consisting of a combination of complex technical systems (systems-of-interest), enabling systems, and organisations operating and maintaining them (Berleur et al., 1993). Simultaneously due to dependence and vulnerability, there are stringent requirements on dependability (Söderholm, 2005).

To ensure a high level of dependability of systems throughout their entire lifecycle, maintenance and the provision of maintenance support is highly important (Liyanage and Kumar, 2003; Söderholm et al., 2007; ISO/IEC, 2008). The reason is that the dependability of a system is a consequence of availability performance and its three inherent factors: reliability performance, maintainability performance and maintenance support performance (IEC, 2004).

---

<sup>1</sup> A complex system is a system-of-systems, which can be divided into a system-of-interest and enabling-systems. A system-of-interest is a system whose lifecycle is under consideration within a given context. An enabling-system is a system that complements a system-of-interest during its life cycle stages, e.g. supplying the necessary support during the operation and utilization of the system-of-interest, but not necessarily contributes directly to its function during operating (ISO/IEC, 2008).

Hence, the provision of maintenance and maintenance support is a key element to ensure agreed level of dependability of systems throughout their life cycle (Coetzee, 1998; Campell and Jardine, 2001; Söderholm et al., 2007; ISO/IEC, 2008), since it includes the resources required to maintain an item under a given maintenance concept and guided by a maintenance policy. The planning and provisioning of maintenance support depends on who takes responsibility for its implementation and which phase of the life cycle that is considered (Blanchard, 2004; IEC, 2004).

The provision of maintenance support to sustain the performance of complex systems-of-systems, needs to consider the initial design of the system-of-interest, which determines its reliability and maintainability, but also the consequences of the intended use of the system and its integration in the customer's business and operational context (Biedenbender, 1993; Blanchard, 2004; IEC, 2004). Hence, the planning and provisioning of maintenance support related to a complex system benefits from being approached simultaneously from both technology and business perspectives.

Both the system-of-interest and its enabling-systems are often complex with a high-technological design. Modern systems-of-interest within power generation, process industry and transportation, e.g. railway vehicles and aircraft, have designs that are software-intensive and have integrated computer systems and intricate sub-system interdependencies. This kind of complex-technical-systems, such as e.g. aircraft, are often produced in multiple variants and configurations, complicating configuration control and change management of modifications and resulting in numerous possible combinations of both hardware and software (Lorell et al., 1995; Ahlgren et al., 1998; Sandberg and Strömberg, 1999).

Modern aircraft are vivid and representative examples of complex technical system with intricate configuration and stringent requirements on performance and safety, as well as the challenges regarding dependability and high requirements on maintenance and maintenance support. (Sandberg and Strömberg, 1999; Ahmadi, 2007; McDonnell and Clegg, 2007).

New technology and innovation also drive development and create new needs. A military example is the so-called fourth generation combat aircraft, e.g. Dassault Rafale, Eurofighter Typhoon and Saab Gripen. These are system aircraft with a digital infrastructure and fully integrated computer systems that utilize a common database through standardized interfaces (Lorell et al., 1995; Ahlgren et al., 1998; Sandberg and Strömberg, 1999). The building principle of a system-of-systems supplies an immense potential for functional development, but also an extremely complex aircraft system (Sandberg and

Strömberg, 1999). The civilian equivalents, such as the Boeing 787 Dreamliner and Airbus A340/320, have also put extensive use of ICT as a central component to, amongst other purposes, achieve more efficient maintenance and support solutions (Canaday, 2004; Careless, 2004).

A central part of this aircraft technology development, related to maintenance, is advanced Built-in Test (BIT) systems. The aircraft BIT is continuously being developed to improve safety, maintainability, testability and supportability of the aircraft as well as to provide health information. This extended access to qualified data from operation and maintenance provides the technical foundation for condition monitoring, extensive data recording, test, diagnostics, prognostics and decision support for condition-based utilization and support (Sandberg and Strömberg, 1999). These technology trends, together with the pervasiveness of ICT in the maintenance system and support processes are also key enabling factors for implementation of remote support services accessible world wide and 24/7. Nevertheless, the BIT is itself a development that adds further requirements and puts strain on supporting ICT frameworks, information logistic processes, and maintenance needs (Söderholm, 2005; Söderholm, 2007; Smith, 2008).

There are also necessary changes and updates of the system-of-interest, which lead to an increased amount of changes in existing information and generate new information. Hence, there is a growing amount of information that needs to be managed during the life cycle of a system-of-interest. (Parida et al., 2004; Parida and Kumar, 2004; Lee et al., 2006)

From a business perspective there is also new challenges related to the planning and provisioning of maintenance support (Seidenman and Spanovich, 2009). Besides a continuous drive for cost-reduction and improved availability performance, a changing business environment requires new and innovative solutions such as Performance Based Logistics (PBL), service solutions, and contracted functions and logistics. These solutions are complex business models where maintenance, and sometimes even whole parts of the operation and maintenance of a system, e.g. entire plants, fleets of rail-vehicles, busses and aircraft; are outsourced to another actor than the original operator or owner. There is a drastic change in the interaction between major stakeholders, such as operators and support providers, by the introduction of concepts such as PBL, where the support providers' commitment increases through the offering of availability performance at a fixed price (Block, 2009). One such example is the Swedish Defence Materiel Administrations (Försvarets materielverk, FMV) that in 2006 started a process for outsourcing the operation of aircraft for pilot training in order to establish a more cost-

effective way of operation (FMV, 2006). Another example is Rolls-Royce's Total Care service agreement, where a single source solution is offered to the customer for the overall lifetime support of the engine, which allows the customers to transfer the technical and financial risks associated with engine aftercare to Rolls-Royce (Rolls-Royce, 2009).

One important consequence of these new business solutions is the need for improved Operational Monitoring (OM) and Life Cycle Management (LCM). For both customers and service providers these new business models increase the importance of evaluation of contracted parameters such as performance and availability. This evaluation requires access to operational and maintenance data and information for assessment, verification and validation. For organisations designing complex technical systems and service providers, the feedback from the maintenance and operation processes also constitutes an essential asset for the continuous improvement of performance of both the system-of-interest and associated enabling systems (Mokashi et al., 2002a).

An important aspect of the presented technological and business challenges, as well as the growing quantity of information related to maintenance and maintenance support, is their effect on the requirements on information support. As information support is a vital part of maintenance support (Kumar, 2003; Goffin, 2000), it is essential that new configurations and change management of HW and SW are matched by corresponding changes and updates of information support products and services. This to assure information quality, safety and applicability, which through their importance for the maintenance support, affects the possibility to perform efficient operation, maintenance, modification and ultimately the performance of the system-of-interest. In addition, enhancement of OM and LCM also adds new requirements on information support for the integration with operation, modification and maintenance processes. Another important foundation, and prerequisite for the requirement on improvements related to information support, is the ability to utilise existing digitalised legacy information. It is necessary to coordinate the acquisition, design and production of new digital information with legacy information, and thereby facilitate the provisioning of effective information support. (McDonnell and Clegg, 2007)

However, the endeavour to improve information support needs to address both business processes and development processes across the entire life cycle, as well as harmonise and integrate the information management activities between different actors within these processes, such as the organisations developing the system-of-interest, enabling systems, as well as sub-suppliers and operators (Blanchard, 2004; Markeset and Kumar, 2003). Efforts to im-

prove reliability performance need to focus on the system function as opposed to component condition (Mokashi et al., 2002b), which need to be reflected in the information support provided. Existing information islands need to be harmonised and integrated, and aspects of information content format standardised and aligned. Improvements of OM and LCM also require a better integration between system-of-interest, associated enabling systems and business processes at all involved stakeholders, e.g. both support providers and support consumers.

From the presented problem complex Information & Communication Technology (ICT), including ICT-related methodologies, become key while addressing strategic issues and challenges. Properly applied ICT has the potential to facilitate information support to the business of product support, the maintenance process and align the maintenance process with other processes (Williams et al., 2002). Examples of such processes are the operation and modification processes, OM and LCM, as well as provide information support that contributes to strategic business objectives and satisfy external stakeholder requirements.

There are emerging ICT-approaches to deal with the complexities of information support solutions, such as eMaintenance (Muller et al., 2008; Lee et al., 2006; Karim, 2008). However, there is a lack of a unified and homogeneous approach to define the basic concept of eMaintenance and its definitions (see, e.g. Lung and Crespo, 2006) and there are several different views.

One perspective is seeing eMaintenance as a maintenance strategy, e.g. electronic task management through the use of real-time data collected through digital technologies, such as remote sensing, mobile devices, condition monitoring, knowledge engineering, telecommunications and internet technologies (Tsang, 2002). eMaintenance can also be described as incorporating monitoring, collection, recording and distribution of real-time system health data, maintenance generated data as well as other decision and information support to different stakeholders (Muller et al., 2008; Levrat et al., 2008). A view that also may be expanded to dispose of limitations such as organization or geographical location and time, and expand the ambition to global, 24 hours a day, 7 days a week (24/7) information exchange. Hence, eMaintenance is regarded has having the potential to improve the management and performance of activities related to the different parts of maintenance processes (Muller et al., 2008), and thereby improve the dependability, safety and Life Cycle Cost (LCC) of complex technical systems. This can be realised through a coordinated application of ICT throughout the maintenance and support processes, thus integrating Built-in Test (BIT) systems, external tests

at different maintenance echelons, technical information, diagnostics, prognostics and other sources of support information.

However, these approaches often focus on either technology or business processes, or on just a few system life cycle stages, e.g. design and development or operation and maintenance. Hence, there is a lack of methodologies and tools that enable full utilisation of ICT in an eMaintenance context for the design, development and provision of information support solutions from a service-oriented perspective that extensively utilises the potential advantages of data and information in maintenance and business processes throughout the entire life cycle of complex systems.

In summary, existing theories related to the development and provision of enhanced information support solutions related to complex technical systems, often focus on either technology or business. Furthermore, the approaches often focus on just a few system life cycle phases, e.g. design and development or operation and maintenance. At the same time there is an underexploited potential in the form of existing support-related data and information, and a lack of harmonisation and integration of existing ICT. Information support requirements from the operational phase and aspects of information content format standardization and alignment are often less emphasised during the development of the system-of-interest. Together these factors limit the development and provisioning of effective information support solutions, which in turn may lead to inefficient operation and maintenance, or even major unwanted effects with far reaching negative consequences on system performance, dependability and cost.

## **1.1 Purpose and Objectives**

The purpose of this research is to describe how providers of support solutions can develop and provide effective information support solutions related to complex technical systems by enhanced utilisation of ICT.

Within an eMaintenance context, the main objectives of the research are to:

- Identify critical information support requirements of customers and support providers for effective development of information support solutions by enhanced utilisation of ICT
- Identify Information & Communication Technology (ICT) related tools and methodologies suitable to fulfil the information support requirements of customers and support providers



- Propose an approach for development and provision of ICT-based information support solutions that satisfy the information support requirements of customers and support providers

## **1.2 Research Questions (RQ)**

RQ1: What are the critical information support requirements of customers and providers?

RQ2: What characterise suitable Information & Communication Technology (ICT) methodologies and technologies for the fulfilment of information support requirements of customers and providers?

RQ3: How can Information & Communication Technology-based information support solutions that satisfy the information support requirements of customers and providers be developed?

## **1.3 Scope and Limitations**

The scope of the research reported in this thesis is focused on a military aviation context for support of operation and maintenance of aircraft. The reason for this focus is that the results wanted by the stakeholders in the research project, are relevant and applicable solutions that can contribute to increased competitiveness of the Swedish aeronautical community.

Furthermore, the research is also focused on ICT-application as support to operation and maintenance of aircraft. The reason for this is that ICT is seen as a key-enabling factor by the involved stakeholders.

Considering system dependability, this research concentrate on maintenance support performance, while reliability performance and maintainability performance have not been in focus. The reason is that maintenance support performance is mainly affected by the maintenance organization and its support resources, e.g. maintenance-related information and information systems, where as the two other dependability factors describe the characteristics of the technical system itself, i.e. the system-of-interest.

The research does not include issues of information support primarily related to asset management, or Supply Chain Management (SCM) of physical assets, e.g. transport logistics, packaging, handling, storage or transportation (PHS&T). The reason is that these processes to great extent are strongly integrated with customer unique business processes, which is considered as context in this research.

## **1.4 Thesis Structure**

**Chapter 1.** 'Introduction and Background' presents the background, problems related to the research area and basic properties of the application domain that has been in focus. It also describes and motivates the research purpose, research objective, research questions and limitations of this research. This chapter motivates the extent of the theoretical framework that is described in Chapter 2.

**Chapter 2.** 'Theoretical Framework and Basic Concepts' – provides the theoretical foundation of the research. It describes theories related to support solutions for complex technical systems, dependability and Integrated Logistic Support (ILS), maintenance and maintenance support, information, requirements and eMaintenance. The theoretical framework has been used to achieve an understanding of the studied domain.

**Chapter 3.** 'Research Methodology' – describes aspects of research, e.g. approaches, purposes, strategies, data collection and analysis. It also motivates the performed research choices related to these aspects.

**Chapter 4.** 'Research Process' - presents an overview of the realization of the research process, compilation and dissemination of results and outcomes.

**Chapter 5** 'Description of Appended Papers'.

**Chapter 6** 'Description of Concept Development'- presents maintenance, maintenance support and information support related to JAS39 Gripen. It also presents a summary of related information support concept development.

**Chapter 7** 'Results' - presents the findings related to the research questions stated in Chapter 1.

**Chapter 8** 'Discussion' - is a discussion of the results described in Chapters 6 and 7.

**Chapter 9** 'Conclusions' - analyses the results presented in Chapters 7 and the discussion in Chapter 8, as well as provides a summary of the research contributions.

**Chapter 10** 'Further Research' - the chapter provides some suggestions for further research.

**'References'** – a list of references.

**'Appended Papers'** – the six papers that are appended.

## **2 Theoretical Framework and Basic Concepts**

*This chapter provides the theoretical framework and basic concepts used within this research.*

### **2.1 Support Solutions for Complex technical systems**

Deming (1994) defines a man-made system as “a network of interdependent components that work together to try to accomplish the aim of the system”. According to Deming there must be an aim for the system, which is clear to everyone within it and the aim must include plans for the future. Management of a system is necessary and requires knowledge of the interrelationships between all the components in the system, as well as of the people working in it. (Deming, 1994).

ISO/IEC (2008) defines a system as “a combination of interacting elements organized to achieve one or more stated purposes”. In the case of this research these elements form a complex technical system, i.e. a complex system of man and machine, which exists in a physical environment as well as in a context of organization, application and praxis.

Blanchard (2001), supplies a more extensive definition of a system: “A 'system' is a construct or collection of different elements that together produce results not obtainable by the elements alone. The elements, or parts, can include people, hardware, software, facilities, policies, and documents; that is, all things required to produce system-level results. The results include system-level qualities, properties, characteristics, functions, behaviour, and performance. The value added by the system as a whole, beyond that contributed independently by the parts, is primarily created by the relationship among the parts; that is, how they are interconnected.”

Blanchard’s (2001) definition points towards the original incentive for a system in terms of requirements and needs which can explain the importance of designing a system, what effect it will have on the customer as well as financial consequences.

Adding the dimension of time in the form of a life cycle perspective on systems and systems development helps to some extent to grasp the extensive scope of large complex technical systems. There are different approaches to the concept of life cycle perspectives, though they often focus on particular properties of the system during its lifetime, like technical reliability (O’Connor, 1991), logistics (Blanchard, 2004) or lifecycle cost and economic analysis (Fabrycky and Blanchard, 1991). A more comprehensive, and for this

research more applicable, approach which connects to the perspective presented above, is supplied by the ISO/IEC (2008), which establishes a common framework for describing the life cycle of man-made systems. Selected sets of the processes supplied by the standard can be applied throughout the life cycle for managing and performing the stages of a system's life cycle.. (ISO/IEC, 2008).

The ISO/IEC standard supplies a detailed breakdown of a system's life cycle into several stages (ISO/IEC, 2008) and there are four stages that are of particular interest for establishing a life cycle perspective on systems for this research:

- Development stage
- Production stage
- Utilisation stage
- Support stage

The development stage is a detailed technical refinement of the system requirements and a design solution that transforms these into one or more feasible products that enable a service during the utilization stage. Operator interfaces are specified, analyzed, designed, tested and evaluated and the requirements on production, training and support facilities are defined. This stage should also ensure that the aspects of production, utilization and support and their enabling system's requirements are integrated into the design, by involving all interested stakeholders. (ISO/IEC, 2008).

The production stage begins with the approval to produce the system-of-interest and production may continue throughout the remainder of the system's life cycle. During this stage the product may change and the enabling systems may need to be reconfigured in order to continue evolving a cost effective service from the stakeholder viewpoint. The production stage may overlap with the development, utilization and support stages. (ISO/IEC, 2008)

The utilization stage starts when the system is installed and taken into use. The stage comprises the operation of the product to deliver the required services with continued operational and cost effectiveness and the stage ends when the system-of-interest is taken out of service. (ISO/IEC, 2008)

The support stage begins with the provision of maintenance, logistics and other support of the operation and use of the system-of-interest, although planning for the stage begins in the preceding stages. The support stage ends

with the retirement of the system-of-interest and termination of support services. It also includes monitoring the performance of the support system and services. (ISO/IEC, 2008)

This operational monitoring (OM) comprises identification, classification and reporting of anomalies, deficiencies and failures of the support system and services. Sandberg and Strömberg (1999) describe this monitoring and follow-up of experience data as done on two levels. One 'micro' level, where examples of experience data are material failures, logistics support times, and spares consumption. Though, to evaluate how e.g. the performance and support cost meet the original requirements on a total system level, operation is summed up and evaluated on a system, or 'macro' level. Activities that may result from the identification and analysis of problems include maintenance as well as minor and major modification of the support system and services.

As discussed in the introduction of this thesis, users of a complex system need support to access and maintain the utility and services which the system-of-interest or product, is to provide. The description of the support stage above illustrates the interaction between the system-of-interest and the enabling support system during the stage where the system-of-interest is operational. Each enabling system has a life cycle of its own and as a system in its own right, it may when appropriate be treated as a system-of-interest. (ISO/IEC, 2008)

Depending on the requirements and expectations of the user of a complex system, the real or potential need of support may or may not be considered a nuisance. Never the less, when maintenance and support system exist, they are meant to compensate for deficiencies or limitations in the design of the system-of-interest. Mizuno (1988) states that the consumer buys the product's usefulness rather than the product itself, and Kotler (1997) argues that "The importance of physical products lies not so much in owning them as in obtaining the services they render ... Thus physical products are really vehicles that delivers services to us.". This view is supported by Grönroos (2007) who argues that in this customer perspective, the major incitement for choosing a solution (goods, service or any combination thereof) is the benefits that it can contribute to the customer's value-generating process.

The user of a complex system needs support to access and maintain the utility and services which the system-of-interest or product, is to provide. This maintenance support consists of resources such as documentation, personnel, support equipment, materials, spare parts, facilities, information, and information systems (ISO/IEC, 2008). According to Goffin (2000), the view of product support has broadened over the past decade and Kumar (2003) pre-

sents a scope of product support that, alongside more traditional service and maintenance, also includes comprehensive documentation. Hence, the provision of the right information to the right information consumer and producer with the right quality and in the right amount, time is also essential (Parida et al., 2004; Parida and Kumar, 2004; Lee et al., 2006).

Support to both customer and product has become central for satisfying customers of high-technology and engineering products (Markeset, 2003), and is regularly identified as playing a key role in surveys published in trade journals from different areas such as the automotive, domestic appliances, aircraft and computing (Goffin, 2000). According to Markeset (2003), customer support is also considered to be important for industries with complex equipment. It is important for industries where complex equipment is failure prone and when failure has serious consequences.

Goffin (2000) presents four major components of customer support strategies as critical:

- Identifying the customer's support requirements
- Design for supportability
- Choosing/managing distribution channels
- Promoting support for competitive advantage

The design of the support system also needs to take into account requirements and prerequisites contextual beyond the system-of-interest (e.g. the aircraft), considering business process requirements and possible customer requirements to consider re-use of existing resources and capabilities (e.g. facilities, manpower, competencies, ICT and standards) as well as needs of operational flexibility, planned modifications, desired levels of standardization and self-support (Careless, 2004).

It is important to bring these considerations to the fore not only during initial development (Blanchard and Fabrycky, 1998; Goffin, 2000; Blanchard, 2001), but also during the operational phase of a system (Sandberg and Strömberg, 1999), as utilization patterns or profiles, of complex technical systems with long life cycles tends to change over time. Furthermore, systems wear and deteriorate during their lifecycle (Blanchard, 2004).

This concurrent design of a support solution, comprising both the system-of-interest and its support systems, therefore need to be highly structured and controlled, i.e. be performed with a process that enables the integration and iterative optimization of the two interdependent elements and system quali-

ties discussed, to meet requirements on system effectiveness at the lowest possible LCC and LSC.

## 2.2 Dependability and Integrated Logistic Support

To ensure dependability of systems throughout their entire life cycle, maintenance and the provision of maintenance support is highly important (IEC, 2004). In turn, dependability of a system is a consequence of availability performance and its inherent factors: reliability performance, maintainability performance and maintenance support performance (IEV, 2008), see Figure 1.

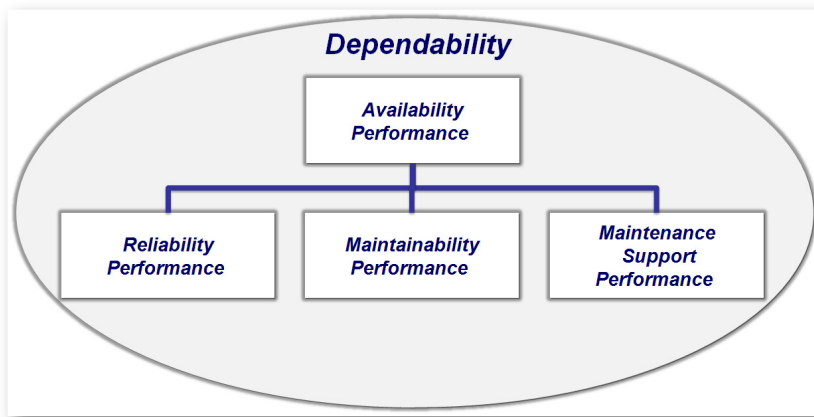

*Figure 1. Elements of dependability.*

Maintenance and support concepts for modern complex technical systems, such as civil airliners and military combat aircraft, can be described as focusing on optimizing two fundamental and interdependent elements.

The first element is the influence on the design of the system-of-interest (e.g. aircraft) to maximize its inherent availability, within available Life Cycle Cost (LCC) requirements. This ensures that the aircraft will have high reliability performance and maintainability performance in relevant operational profiles and support environments. The second element concerns the design of the maintenance and support system, which provides necessary support during the operation and maintenance phases of the system-of-interest.

It can be noted that for a complex technical system, it is in practice almost impossible to design out maintenance completely. Furthermore, insufficient or erroneous maintenance efforts may result in decreased quality, incidents and accidents. It is therefore of paramount importance that maintenance and

support concepts are designed correctly during the initial phase of a system’s lifecycle (Blanchard and Fabrycky, 1998; Goffin, 2000; Blanchard, 2001).

This is not only to secure the performance of a complex system, but also because maintenance has a major impact on a complex system’s Life Cycle Cost (LCC) (Blanchard, 1998; Markeset and Kumar, 2003). As maintenance and support system should compensate for deficiencies in design of the system-of-interest, insufficient reliability and maintainability performance incur the need of expensive logistic resources such as spares, manpower, ICT and facilities, all of which increase Life Support Cost (LSC) and LCC.

As design decisions implicate technological and economic commitment, it also becomes more difficult and more costly to introduce system changes in the latter part of a system life cycle, rather than in the early phases of conceptual and preliminary design (Fabrycky and Blanchard, 1991). See Figure 2.

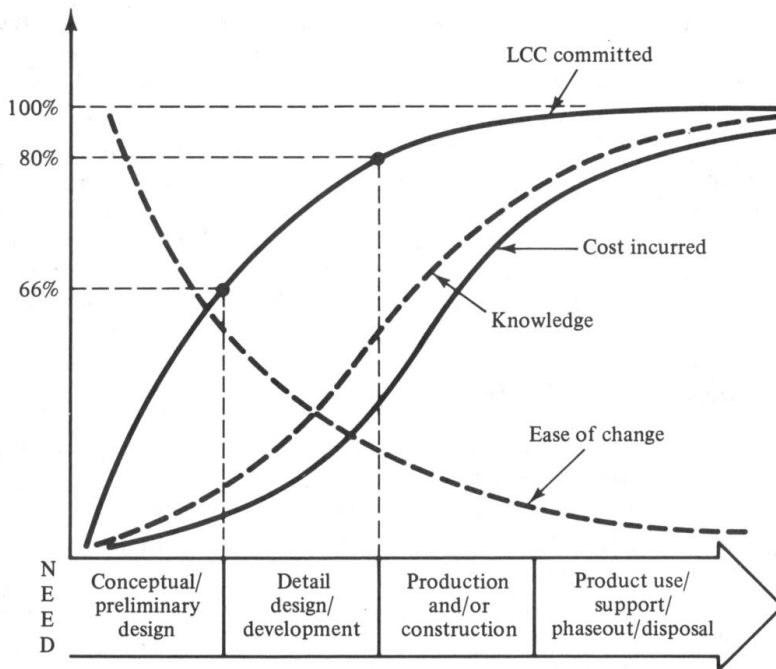

**Figure 2.** Life cycle cost committed and cost incurred, during a system life cycle (Fabrycky and Blanchard, 1991).

Applying the dimension of time in the form of a lifecycle perspective on systems and systems development helps to shed light on the extensive scope of large complex technical systems. There are different approaches to the concept of life cycle perspectives, though they often focus on particular proper-



ties of the system during its lifetime, like technical reliability (O'Connor, 1991) or LCC and economic analysis (Fabrycky and Blanchard, 1991). A life cycle perspective also needs to address the importance of the support system and continuous improvements for a system-of-interest with a life expected to span over decades (Sandberg and Strömberg, 1999).

The approach of the domain of Integrated Logistic Support (ILS) in the presented research is mainly from an engineering perspective, integrated with business-related perspectives, considering all, or applicable, phases of a system lifecycle.

Integrated Logistic Support (ILS) is a structured methodology by which all the logistic support services required by a customer can be brought together (DoD, 1986; IEC, 2001; Blanchard, 2004). The ILS principle of design influence, is stated by UK Ministry of Defence (MOD) (2008) as "The timely application of informed influence to the design of the hardware, software and human aspects of a mission system in order to minimise support related risks and any potentially adverse effects of the design of the mission system on the support requirements, costs and operational readiness".

The purpose of Integrated Logistic Support (ILS) as an approach, and the application of a special system development process for ILS solutions, can be described as the need to develop and establish a well coordinated or integrated, maintenance system that meets stakeholder requirements and has a verified and validated capability to support a given operational capacity of a primary product or system. (Blanchard, 2004; US DD, 1997; Biedenbender, 1993)

Logistic Support Analysis (LSA), also sometimes referred to as Maintenance Engineering Analysis, is performed during the early phases of the life cycle, and is a part of ILS (Blanchard, 2004; Biedenbender, 1993). Given the (proposed or actual) design of a primary system (e.g. aircraft), the LSA defines support activities, maintenance tasks, support equipment, training needs, and provision of technical documentation. The LSA results, in the form of data and information, are integrated into a dynamic supportability database known as the Logistic Support Analysis Records (LSAR). This database is a central configuration-controlled and change-managed product data repository, and needs to be continuously updated during the in-service phase to support the improvement of the maintenance system and the system-of-interest. (Blanchard, 2004; US DD, 1997; Biedenbender, 1993)

Even if opportunities to affect availability performance, maintenance system and life cycle cost are decreasing over time, efforts to optimize performance

versus cost should not be decreased in the later phases. Without operational monitoring and active life cycle management one might very well end up with a situation where expenditures are running out of control due to unexpected changes. Therefore the optimization efforts must not be seen as finished after the major development, but must continue during the operational phase (Sandberg and Strömberg, 1999).

### **2.3 Maintenance and Maintenance Support**

Providing maintenance and maintenance support, which as discussed earlier are parts of an ILS solution, is also one of the main enabling factors to ensure dependability of systems throughout their whole life cycle (IEC, 2004).

Maintenance can also be described as a multi-disciplinary activity which involves: understanding of degradation mechanism and linking it to data collection and analysis; provision of quantitative models for prediction of the impacts of different maintenance actions; and strategic maintenance management (Murthy et al., 2002). Murthy et al. (2002) also define three main steps related to maintenance management: understanding the system-of-interest; planning optimal maintenance actions; and implementing these actions.

Maintenance can be divided into preventive and corrective, which are to be considered as two different strategies. Preventive maintenance means proactive activities to avoid problems that might occur in the future. Corrective maintenance implies reactive actions to correct faults that have occurred.

All resources required to maintain an item under a given maintenance concept and guided by a maintenance policy are referred to as maintenance support (IEC, 2004). Maintenance support could consist of e.g. spare parts, materials, personnel, support equipment, facilities, documentation, information and information systems.

To implement and actually perform maintenance of complex technical systems it is necessary to define a maintenance philosophy, maintenance policy and a maintenance process. The system of principles used for the organization and execution of the maintenance, is defined as a maintenance philosophy (IEV, 2008). The maintenance philosophy provides a framework for an overarching perspective on maintenance in a given organization. It has an impact on the time and place, as well as on how the maintenance is performed.

The maintenance philosophy, in turn, shapes and drives the maintenance policy, which is a general approach to the provision of maintenance and mainte-

nance support based on the objectives and policies of owners, users and customers (IEC, 2004). The maintenance policy describes the relationship between the maintenance echelons, the indenture levels and the levels of maintenance to be applied for the maintenance of an item (IEV, 2008), and provides a guide for the organizational aspects of performing maintenance, see Figure 3.

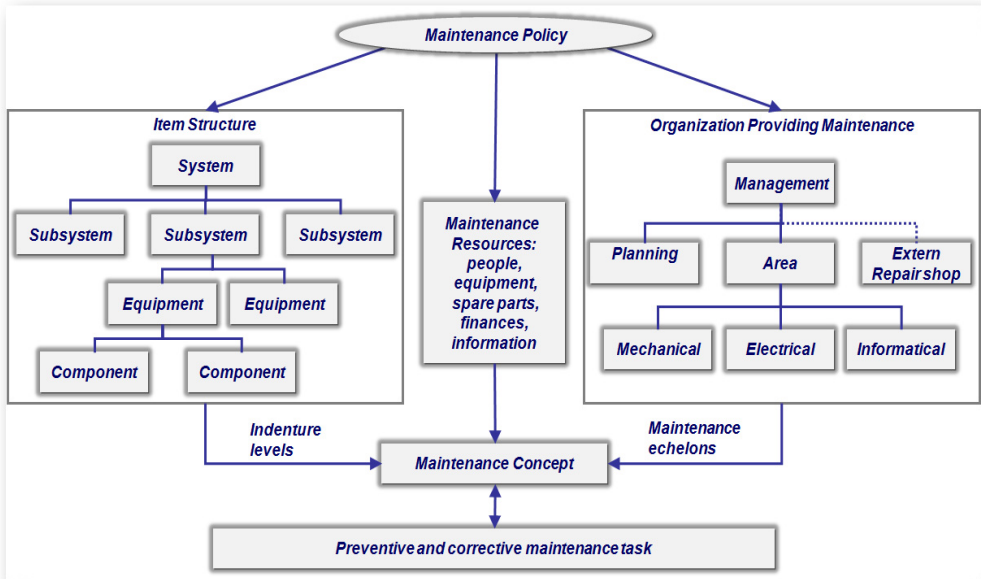

**Figure 3.** Constitution of maintenance policy (IEC, 2004).

To get a more comprehensive understanding of the maintenance of a complex technical system, it is beneficial to consider its implementation in a generic, industrial maintenance process.

An generic industrial maintenance process covers a spectrum of activities required for managing, planning, preparing, executing, assessing and improving maintenance (Liyanage and Kumar, 2003; Söderholm et al., 2007; ISO/IEC, 2008). They involve a wide range of roles, such as managers, process owners, maintenance technicians, maintenance planners and logistic managers, see Figure 4.

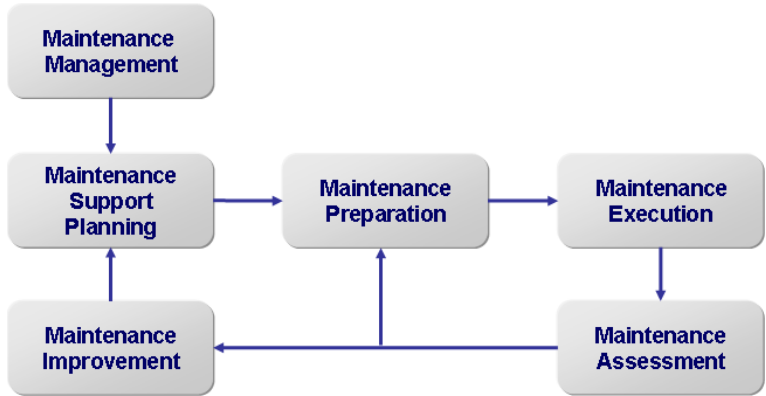

Figure 4. Phases of an overall maintenance process

### 2.4 Maintenance of complex technical systems

The solution for maintenance of a complex technical system such as an aircraft, is an inherent part the design philosophy of a hierarchy of technical components, illustrated in Figure 5 by the JAS39 Gripen and its engine subsystem providing an example.

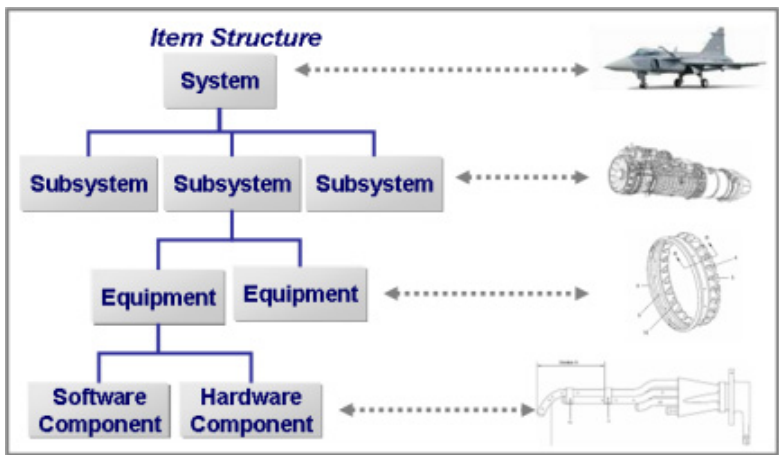
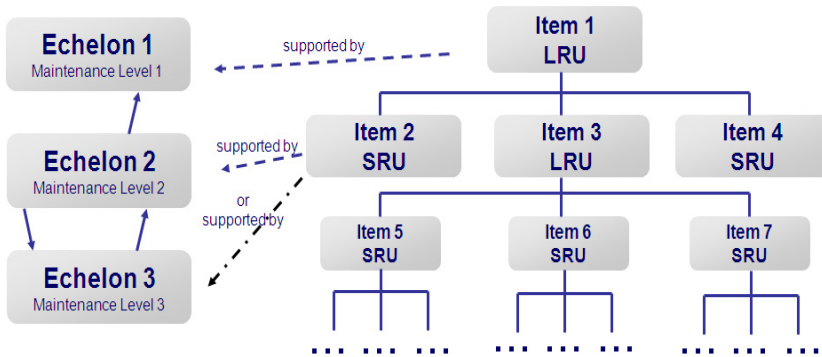

Figure 5. As a vivid example of a complex technical system, a modern combat aircraft has a hierarchical and very intricate configuration and item structure.

Looking at a complex technical systems and its components is from a maintenance perspective, as illustrated in Figure 6, the maintenance solution is based on the use of maintenance echelons (usually three, although other solutions also exist). Figure 6 illustrates how the complete aircraft is placed on the 1st indenture level (i.e. Echelon 1). Its subsystems, e.g. the engine, are placed

on the 2nd level (Echelons 2). The engine's constituents, e.g. the spraybar slots and its spraybars, are placed on the 3rd level (Echelon 3).



*Figure 6. Structure of maintenance items, the echelons, and their relationship*

Here, certain equipment and assemblies of items or components are defined as Line Replaceable Units (LRUs) or Shop Replaceable Units (SRUs). From an maintenance perspective, this classification indicates the way these items are maintained. Both LRUs and SRUs may consist of hardware and software components.

When required the LRUs are removed and replaced at the deployed site of the system (i.e. aircraft), for instance, in the field (i.e. Echelon 1). By doing this, one quickly restores the system (e.g. aircraft) to an operational condition without the need of extensive maintenance resources in the field. The SRUs may then be attended to at a shop level (e.g. at Echelons 2). To attend to a faulty SRU, it must first be removed from its closest LRU parent, and take it to a shop (usually at Echelon 2 or 3), where a technician gets inside it to remove the faulty SRU.

## 2.5 Information

Information is the core of maintenance related processes and decision processes. Information support is critical for successful execution of maintenance tasks, and also for meeting maintenance objectives such as availability, reliability and performance insurance. In general, the product development process is of great importance for both production and usage cost, as well as for a number of quality aspects about a product (Bergman and Klefsjö, 2003). This is also applicable to information products for complex technical systems, which are, in this respect products just like any other. An important part of the development process is the ability to effectively manage requirements,

not least from an economic point of view (Karlsson, 1995). Information services has an impact on a number of different users and stakeholders and several of them have their own requirements, as there may be a wide variety of actors that are stakeholders in information services for complex technical systems.

Development of information for users is primarily an issue about content and meaning and should according to Jacobson (Jacobson, 2000), not primarily take off in discussions about media or technology for the transfer of the message. However, Sonesson (2000), Jernbäcker (2003) and Canaday (2004) discuss the advantages of utilizing digital information support compared to traditional print, for user information for operative technical personal working with complex technical systems such as aircrafts. Similar experiences are presented by Drury (2000), whose study showed that a computer-based system of work cards for aircraft inspection was a significant improvement compared to the a paper-based solution.

In the end, aspects of both content and technology need to be taken care of as the process of supplying user information can be described as a chain of functions, starting at the design of the actual technical system and ending at the time and place where the users need support. Throughout this development and provision process, large numbers of requirements of all kinds need to be collected, managed and incorporated into the product, to be able to satisfy the needs of the different users at the end.

Hence, when dealing with establishment of information support solution for complex technical systems, it is widely accepted that the utilization of a framework increases the effectiveness and efficiency of the inherent phases, since a framework can provide a structured set of concepts, models, guidelines and technologies. (Karim, 2008)

## **2.6 Requirements and QFD**

Is very important to assure a complete collection of requirements as requirements are to drive the system design and operation (Kar and Baily, 1996). This is, on one hand, an act of balancing between an excess of requirement driving unnecessary costs and hindering an optimum system solution. On the other hand insufficient requirements can cause large amounts of rework as the requirements are instead likely to be deduced during later stages of development when the implementing cost is higher. (Carson, 1998)

Guidance and definition of those who have the right, or duty, to state requirements, i.e. stakeholders, are available are amongst others in the ISO/IEC standard (ISO/IEC, 2008), which defines the term stakeholder as “a party

having a right, share or claim in a system or in its possession of characteristics that meet that party's needs and expectations".

QFD enables transfer of requirements to the design process through matrix diagrams. By doing so, the original needs and requirements of the customer ("what") are systematically transformed into product qualities ("how") through a controlled and traceable process (Akao, 1992). See Figure 7.

Yoji Akao (1992) defines Quality Function Deployment (QFD) as "a method for developing a design quality aimed at satisfying the consumer and then translating the consumer's demands into design targets and major quality assurance points to be used throughout the production phase".

Matrix diagrams are highly functional for identifying and assessing connections and interdependencies between different factors (Klefsjö et al., 1999). The methodology of interest for this research, is applying matrix diagrams integrated with QFD.

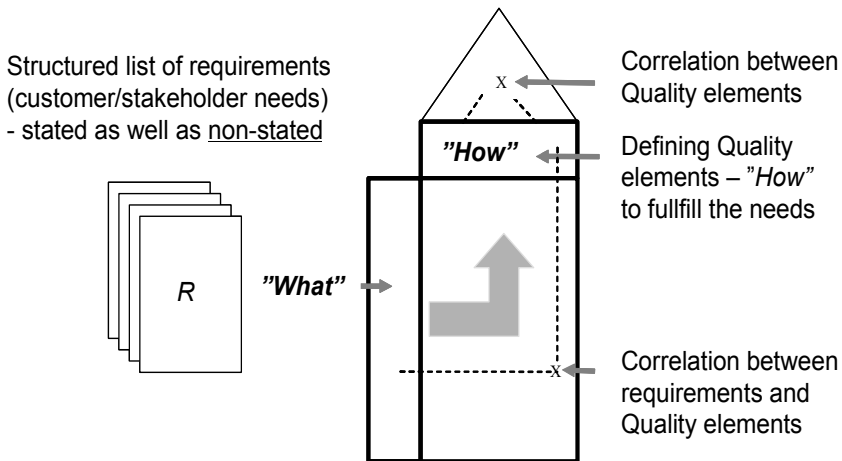

**Figure 7.** Matrix diagram, development of requirements to product qualities, inspired by Akao (Akao, 1992).

QFD has numerous applications and is used in different contexts, of which software development is one example (Yoshizawa et al., 1992; Chan and Wu, 2002; Herzwurm and Schockert, 2003).

Characteristics of QFD are:

- Stakeholder and customer focus
- Cross-functional work
- A structured methodology of working, with system level analysis
- Clear and distinct documentation, enabling traceability

In essence it is about translating the "word-of-the-customer" to the "word-of-the-company" and QFD enables the collection of the "word-of-the-customer" with reference to a certain product (Schütte, 2002). The first model or representation consists of the requirements of external stakeholders. This representation is then transformed in a suitable number of steps, in which successive clarifications and realizations are introduced. The final step results in a finished tested and approved system product, for instance a physical product, software or a service.

QFD also enables systematic communication between stakeholders and the design team (Karlsson, 1998) and is thereby useful both for the specification and development of a product (artefacts as well as services).

Prioritization and selection processes must consider the importance of different demands as well the different costs associated with their implementation (Karlsson, 1995). QFD addresses these issues in general terms, though it needs to be adapted to fully fit the purpose of information support development.

QFD can, in the way it has been used in product development, be subdivided into four steps: Product planning, Parts deployment, Process planning and Production planning (Bergman and Klefsjö, 2003). Analogies to the first two of these steps are of primary interest for this study:

**Product planning.** The purpose of adapting product planning is mainly to preliminary design and test a methodology for the capture and translation of user-stakeholder demands and requirements into product qualities.

**Parts deployment.** This step aims to choose the best design concept for fulfilling requirements and goals for the design qualities or characteristics.

The number of steps and their designations do not govern the use of QFD methodology. QFD has to be adapted to the problem under study. In an extensive literature review by Chan and Wu (2002), the adaptation and use of QFD methodology has been identified within a vast number of problem areas. Within software development interesting adaptations have been made



and a comprehensive model has been developed by Zultner (1993). This process is built on two phases:

- Requirement identification
- Requirement analysis

These are followed by work along three tracks:

- Functional development
- Information development
- Service development

QFD and the issue of information support from a design quality and customer requirements perspective show several similarities with QFD in software development. Requirements are often 'soft' and are difficult to measure (Akao, 1992)

## **2.7 eMaintenance**

eMaintenance has been described widely from different perspectives (Lung and Crespo, 2006). Some of these descriptions are:

- A maintenance strategy (Tsang, 2002)
- A model that enhances the efficiency of maintenance activities by applying ICT for the provision of information (Tsang, 2002).
- A support to execute a proactive maintenance decision-process (Muller et al., 2008),
- A predictive maintenance system that provides monitoring and predictive prognostic functions (Koc and Lee 2001; Parida and Kumar, 2004)
- The integration of all necessary ICT-based tools for optimization of costs and improvement of productivity through utilization of Web services (Bangemann et al., 2004, 2006)
- Infrastructure for mobile monitoring technology in the DYNAMITE project (IST, 2008)
- Common database concept for maintenance-related information (Kans, 2008)

New innovations based on electromechanical and software technologies, successfully infused into the parent systems of existing products and product

platforms have the potential to deliver value. Such innovations can be based on individual components, but are generally larger in terms of scope and their impact on the underlying product architecture and functionality. However, such technologies cannot solve the challenges of designing competitive solutions by themselves. Only if they are fully integrated into their host systems do they gain the potential to deliver value. (Henderson, 1990; Suh et al, 2009).

There are some basic views of eMaintenance that can be seen in the literature, where common denominators often are the monitoring, recording, and transfer of data and information. However, two different emphases are: (1) information distribution between humans (and organizations) and (2) remote maintenance and autonomous systems, where information is transferred between technical systems and humans. In both situations there are technical systems and humans presents, but the data and information flow is aimed at different stakeholders. (Muller et al., 2008)

A third possibility that can be found is the combination of both aspects of eMaintenance, but the emphasis is still often on one of the two aspects and not both of them.

The combination of modern information processing and communication tools, commonly referred to as tele-service, offers the technical support required to implement this remote service maintenance. However, this technical support is insufficient to face new remote maintenance decision-makings which require not only informational exchanges between customers and suppliers but also co-operation and negotiation based on the sharing of different knowledge. It requires an evolution from tele-service to eService and eMaintenance in particular where the maintenance decision-making results from the collaboration of maintenance processes and experts to form a distributed artificial intelligence environment. (Yua et al., 2003)

Via such e-services, remote operators could tap into specialized expertise rapidly without travel and scheduling delays. Training costs could be reduced while effectiveness enhanced by using the best teachers available. According to Hamel (2000), downtimes could conceivably be reduced through direct interaction (trouble shooting) with source designers and specialists.

One example of an area with great improvement potential is technical publications. A large proportion of the information support used by maintenance actors within aerospace is still paper documents, or 'paper-on-screen' solutions (e.g. paper documentation published in PDF-format). This practice prevails despite the fact that new aircraft complexity, integrated digital systems

and air-to-ground real-time communication technologies make document-oriented, paper-based approaches increasingly expensive to produce and of inadequate usability.

Hence, unnecessary costs are generated simply because maintenance actors often lack information support products and services that are adapted to specific roles and situations, and therefore cannot work as efficiently as possible. (Candell and Söderholm, 2006; Canaday, 2004; Candell, 2004). There is also, from a business perspective, a need to apply a process-oriented approach to servicing and maintenance rather than the current system approach (Jensen, 2008) and in addition also to enhance the utilization of ICT within aerospace domain (Saab, 2005; Saab, 2007a; Saab, 2007b, Saab 2007c, Saab, 2009b).

With reference to the problem and solution domains presented above, the concept of eMaintenance presented in this research can be defined as a structured and coherent application of ICT throughout the whole life cycle of the support system, coordinated with technical solutions in the aircraft system. The main goal is to create a more effective and efficient maintenance process by optimizing an eMaintenance framework as a part of necessary maintenance support implemented in the enabling systems, and thereby improve overall system effectiveness.



### **3 Research Methodology**

*This chapter presents some theories of research methodology and the choices made within this research.*

#### **3.1 Purpose of the Research Work**

Science can in a theoretical perspective be described as activities through which researchers produce different kinds of knowledge (Patel and Davidson, 2003). This production of knowledge is to enable the creation of descriptions as well as models and theories for different phenomena (Holmberg, 1987).

Most scientific studies can be classified according to which type of knowledge they aim to produce, usually exploratory, descriptive or explanatory. An exploratory study has the purpose of creating understanding of a particular problem area, and may be used when the existing knowledge of the area is limited. Descriptive studies are performed with the purpose of describing a certain phenomenon. Explanatory research consists of empirical tests of hypotheses about causal relationships between different phenomena. (Patel and Davidson, 2003).

As the purpose of this research is to explore and describe how providers of support solutions can develop and provide effective information support solutions related to complex technical systems by enhanced utilisation of ICT, the research is both exploratory and descriptive. The exploration of the domain will generate knowledge to be used to improve user information development, thus being a part of the continuous improvement work at the participating companies and other interested parties. The descriptive approach has, among other properties, the ability to communicate information about a more general phenomenon to different stakeholders, by placing the subject matter in a broader context (Yin, 2003). The descriptive approach supports a structured study of important aspects of a process for user information development that consider satisfaction of stakeholder needs as a central product quality.

#### **3.2 Research Approach**

Looking at research as knowledge generation, Holmberg (1987) describes the way of proofing or deduction, and the way of exploration or induction, as two alternative roads. Deduction has existing theory and concepts as its points of departure, which are tested, and delivers acceptance (or not) of the theory tested (Gummesson, 2000). Induction can be described as an approach

based on empirical, or real-world data, where the results of the study according to Gummesson (2000) primarily generate new theory.

Gummesson (2000) also argues that after the initial stages, all types of research become an iteration between the deductive and inductive. This is referred to as abductive research, which is to be seen as a combination of deduction and induction, rather than regarded as a third approach (Gummesson, 2000). Alvesson and Sköldbberg (1994) describe abduction as a process originating in a deductive approach, where empirical material is collected based on a theoretical framework, followed by an inductive phase where theory is developed on the basis of the empirical data collected in the first phase. An important aspect of abduction, according to Alvesson and Sköldbberg (1994), is that the process also encompasses a gradual development of the area of empirical application, as well as an adjustment and refinement of the theory.

The research process presented in this thesis is in the initial phase deductive, due to the ambition to look into earlier research for a theoretical framework of knowledge about, and methodology for, how support solutions can develop and provide enhanced information support solutions related to complex technical systems by improved utilization of ICT. The purpose of this theoretical framework is to supply a base and guidance for the collection of empirical data, and the adaptation of a process for the development and provision of enhanced information support solutions related to complex technical systems by improved utilization of ICT.

The analysis model is then evaluated, exploring the empirical domain and data from the JAS39 Gripen complex technical system. This knowledge is then used to evolve and refine the continued empirical work during a concept development, in parallel to a final inductive phase, forming a more generalised process for the development and provision of information support solutions.

Research approaches utilising numerical measurement during data collection, as well as statistical processing and analysis, are often referred to as quantitative. Qualitative approaches include collection of “soft” data, for example, interviews, and verbal analysis of text material. (Patel and Davidson, 2003).

The data and information confronted in the empirical part of the study are mostly of a qualitative nature. This, together with the fact that exploration of the studied process is of main interest, calls for a qualitative study approach.

### 3.3 Research Strategy

The purpose of the research has an intrinsic vagueness due to the lack of previous research and deeper theoretical knowledge about the problem domain. A sound research strategy according to Yin (2003) for a first phase of study is in such cases to increase knowledge by literature studies, and to build on existing theory from different domains to provide a theoretical basis for the following work.

According to Yin (2003) the choice of research strategy is a choice of a way of collecting and analyzing empirical evidence, and different strategies have different pros and cons. Yin (2003) presents three conditions for the choice of research strategy:

- Type of research question
- The investigator's extent of control over behavioural events
- Degree of focus on contemporary versus historical events.

These conditions and their relation to five major research strategies are presented in Table 1.

*Table 1. Relevant situations for different research strategy (Yin, 2003).*

Strategy	Form of Research Question	Requires Control over Behavioral Events?	Focuses on Contemporary Events?
Experiment	How, why	Yes	Yes
Survey	Who, what, where, how many, how much	No	Yes
Archival Analysis	Who, what, where, how many, how much	No	Yes/No
History	How, why	No	No
Case Study	How, why	No	Yes

This is to be compared to the research questions in the research:

- RQ1: What are the critical information support requirements of customers and providers?
- RQ2: What characterise suitable Information & Communication Technology (ICT) methodologies and technologies for the fulfilment of information support requirements of customers and providers?
- RQ3: How can Information & Communication Technology-based information support solutions that satisfy the information support requirements of customers and providers be developed?

Research questions 1 and 2 are “What”-questions. These are mainly of an explorative nature and are intended to develop relevant hypotheses and propositions for the continued study. They are, however, not ‘what’-questions in the sense of ‘how many’ or ‘how much’, which would favour survey or archival strategies (see Yin, 2003).

Regarding research question 3 focusing on “How”, the control over behavioural events is estimated as limited and the study focuses on contemporary events. This perspective supports a decision to choose case studies as a preferred strategy. An advantage of a case study strategy is also that it is able to support the potential needs of this study to contain elements that are exploratory as well as descriptive and explanatory (Yin, 2003).

The development and evaluation of an information support concept may also be regarded as a form of methodology or tool, and is interdependent with the “What”-questions. “What”-questions of an exploratory nature may, according to Yin (2003), be addressed using any of the strategies applicable. The case study strategy is also supported by the literature study, which builds a theoretical framework of knowledge from related domains.

A primary distinction in case study design is, according to Yin (2003), between single and multiple case designs. In many circumstances, the single-case study is an appropriate design, analogous to a single experiment and justifiable especially for the unusual or rare case and when the conduct of a multiple-case study requires resources and time that are beyond a single researcher. Single case study is in turn divided into holistic or embedded. The embedded case-study design includes more than one unit of analysis, i.e. when attention within a single-case is also given to a sub-unit or subunits. Holistic designs, on the other hand, are said to be used if the case study examines only the global nature of a programme or organization. (Yin, 2003).



The phenomenon that this study is to explore and describe is the development of information support solutions for complex technical systems. This implies a unit of analysis, i.e. the level of inquiry that the study will focus on, that is a development process for a team or organization. This suggests, according to Yin (2003), a holistic case study design. Also important for the understanding of the explored and described phenomena are the methodology and tools that support the development of information support solutions for complex technical systems, including the process and service oriented approach and the development of an information support concept as a part of the development strategy.

The discussion above leads towards a single-case embedded design. The comprehensive qualitative approach of the study focuses as much on the process and context of information support development, as on specific details. The main unit of analysis is the development process for a team or organization to develop information support services and products. The supporting methodologies and tools, including the process and service approach and the development of a concept as a part of the development strategy, are sub-units of analysis.

### **3.4 Data Collection**

There exist several sources for data collection (or sources of evidence) that can be used in a case study according to Yin (2003), who presents six main sources of evidence; documentation; archival records; interviews; direct and participant observations and physical artefacts. All these ways, together with their strengths and weaknesses, are presented in Table 2. However, the starting point for qualitative research is that individuals have common experiences and circumstances in an organization or profession, and that it is possible to identify common patterns and describe them. Still the situation of each individual is unique, and they can contribute with unique information and knowledge to the research (Patel and Davidson, 1987).

Much of the data connected to the units and sub-units of analysis and needed to address the purpose and research questions of this research have been collected by the research team for the purpose of the presented study. This is called primary data, to be compared with secondary data, which is data already collected by other people and then used by the researcher (Dahmström, 1996). According to Dahmström (1996), the advantage of primary data is that relevance is likely to be higher than for secondary data, and that it is also easier for the researcher to evaluate primary data and assess its reliability (Dahmström, 1996).

The data collection methodology for this study encompasses direct and participant observations, action research and document studies. These are consequences of the purpose of the project, the goals and research questions as well as the chosen research strategy and the circumstances for the data collection described earlier.

*Table 2. Six sources of evidence: strengths and weaknesses (Yin, 2003).*

Source of Evidence	Strengths	Weaknesses
Documentation	<ul style="list-style-type: none"> <li>• Stable – can be reviewed repeatedly</li> <li>• Unobtrusive – not created as a result of the case study</li> <li>• Exact – contains exact names, references, and details of an event</li> <li>• Broad coverage – long span of time, many events, and many settings</li> </ul>	<ul style="list-style-type: none"> <li>• Retrievalability – may be low</li> <li>• Biased selectivity, if collection is incomplete</li> <li>• Reporting bias – reflects (unknown) bias of author</li> <li>• Access – may be deliberately blocked</li> </ul>
Archival Records	<ul style="list-style-type: none"> <li>• Same as above for documentation</li> <li>• Precise and quantitative</li> </ul>	<ul style="list-style-type: none"> <li>• Same as above for documentation</li> <li>• Accessibility due to privacy reasons</li> </ul>
Interviews	<ul style="list-style-type: none"> <li>• Targeted – focus directly on case study topic</li> <li>• Insightful – provide perceived causal inference</li> </ul>	<ul style="list-style-type: none"> <li>• Bias due to poorly constructed questions</li> <li>• Response bias</li> <li>• Inaccuracies due to poor recall</li> <li>• Reflexivity – interviews give what interviewer wants to hear</li> </ul>
Direct Observations	<ul style="list-style-type: none"> <li>• Reality – cover events in real time</li> <li>• Contextual – cover context of event</li> </ul>	<ul style="list-style-type: none"> <li>• Time-consuming</li> <li>• Selectivity – unless broad coverage</li> <li>• Reflexivity – events may proceed differently because they are being observed</li> <li>• Cost – hours needed by human observers</li> </ul>
Participant-Observations	<ul style="list-style-type: none"> <li>• Same as above for direct observations</li> <li>• Insightful into interpersonal behavior and motives</li> </ul>	<ul style="list-style-type: none"> <li>• Same as above for direct observations</li> <li>• Bias due to investigator’s manipulation of events</li> </ul>
Physical Artifacts	<ul style="list-style-type: none"> <li>• Insightful into cultural features</li> <li>• Insightful into technical operations</li> </ul>	<ul style="list-style-type: none"> <li>• Selectivity</li> <li>• Availability</li> </ul>

The border between participant observations and action research is not obvious. According to Patel and Tibelius(1987), action research is characterized by

the strivings to reduce the distance between theoretical knowledge and practical application. Gummesson (2000) describes action research as involving participation with active intervention in decision-making, implementation and change processes.

The origin of the research presented in this thesis is a defined problem of practical application, addressed partly through action research. The flipside of direct and participant observations is that they are time-consuming and selective, which might restrict the range of material studied (Yin, 2003). Such observations might also be biased due to the presence and participation of the researcher.

These disadvantages must be balanced against the need for access that Gummesson (2000) describes as essential to establish, when dealing with decision processes and processes of implementation. This access is also essential for the decision of the character, scope and allocation of the support needed for a system (Markeset and Kumar, 2003). Decisions about support also assume knowledge about the environment for the operation, as well as organizational and cultural issues, according to Markeset and Kumar (2003). Therefore, access is important when one needs to study the joint system of man and machine; studies which are to be done in real life, in its social and organizational context rather than outside it, which is stressed by Hoc et al. (1995) and Hutchins (1995). However, the close involvement of the researcher is also a potential source of bias of the observations. Actions to reduce this risk in this research project have included the submission of notes for review to participants in workshops.

Another potential impact of the bias of the action researcher is, according to Gummesson (2000), the formulation of the research question and the selection of the domain for empirical study, as well as the origin and organization of the study or its purpose in a context of application. However, on the positive side, Gummesson (2000) argues that the same bias that might influence these aspects negatively, also contributes positively to the relevance of the research and its empirical grounding, i.e. a good connection to reality.

The author's work on the research presented in this thesis was performed both in his role as an industrial PhD student and as a Saab employee. As such, access was granted to unique knowledge, experience and empirical material. The close involvement and the author's multiple roles, or "action research" as described in the literature (Patel and Tibelius, 1987; Gummesson, 2000; Bryman, 2001), shed particular light on special aspects of the research process.

The roles and involvement of the author and the concept development pointed towards direct and participant observations and action research as the main ways of collecting data. According to Yin (2003) and Gummesson (2000), these are methodologies for collecting information, which supply unique access to context and interpersonal behaviour, as well as insight into cultural features and technical operations.

The theory and hypotheses from the literature studies are to be analyzed in connection with their methodological consequences for the stated research question. This leads to a more detailed methodological approach. According to Bryman (2001), this approach should drive the subsequent process of gathering empirical data.

Regarding data analysis, Yin (2003) describes the analysis of case study data as consisting of “examining, categorizing, tabulating, or otherwise recombining the evidence to address the initial propositions of the study”. There are, however, few well-defined, established and widely accepted rules for the analysis of qualitative data, unlike for the analysis of quantitative data (Yin, 2003; Bryman, 2001).

Miles and Huberman (1994) present an overarching view on the analysis of qualitative data as the tasks of data reduction, data display and conclusion drawing. The analysis in this research has adapted Miles and Huberman’s (1994) view, and has mainly been performed as data reduction, interpretation of data, data display and conclusion drawing.

It is necessary, according to Yin (2003), for every investigation to start with a general analytic strategy as a guide for choices of what to analyze and why. A preferred strategy is to rely on the theoretical propositions that led to the case study (Yin, 2003). Although there are no such direct propositions in the purpose or primary research question of this research, the detailed research questions can be regarded as indirect propositions.

The approach of performing analyses continuously during a qualitative study is based on the fact that it is often practical, as it may supply knowledge and ideas for the development and improvement of the subsequent work (Bryman, 2001; Patel and Davidson, 2003). The results and experiences from the initial phases of the research are used as feedback for the continuing research and a refined adaption of the suggested development process.

The evaluation of the suggested development process is closely analyzed during and after its application in the concept development, to establish its effect on the process and the result. The concept development process comprises collection of additional stakeholder requirements and empirical material re-

garding system and user contexts, as well as the actual development work applying and further adapting and refining the suggested development process of information support services.

### **3.5 Reliability and Validity**

The conception of validity in qualitative research comprises the entire research process, and is to lesser extent confined to the process and technique of measuring as in quantitative studies. Qualitative research is driven by the ambition to discover phenomena, to interpret and understand the meaning of deeper values, as well as to describe perceptions or a culture. If, for instance, the researcher gets different answers asking a person the same question on different occasions, it is in a quantitative study regarded as a sign of low reliability. This is not necessarily the case in a qualitative study, as it may indicate that the person interviewed has changed his view of the matter, learnt something or that the circumstances of the issue have changed. To the qualitative researcher, this change might very well supply additional information and become an asset, rather than a liability. The reliability should be viewed in the circumstances of each unique situation. From this perspective, the concept of reliability is to be seen as converging with the concept of validity in qualitative studies. (Patel and Davidson, 2003)

It is also easily verified with rudimentary logic; a test can be reliable without being valid, but not the other way around, i.e. reliability is necessary but not enough to assure the quality of research. To achieve that, the research also needs to be valid.

Yin (2003) discusses two types of validity applicable for exploratory and descriptive case studies. One is construct validity, which is to establish the correct operational measures for the concepts being studied. The use of multiple sources, establishing chains of evidence, as well as letting key informants review draft study reports during data collection and composition, are ways to increase construct validity. The other is external validity, which is about establishing the domain to which the study's findings can be generalized. As case studies do not rely on statistical generalization (as for instance surveys do), the possibility to generalize depends on replication logic and the ability to analytically generalize from the results. (Yin, 2003).

The goal is to minimize bias and errors in the study. Keeping a case study protocol during data collection and maintaining a structured filing system are effective ways to increase reliability (Yin, 2003). Different actions are applied in the research project presented in this thesis to increase reliability. One example is to improve the quality of the notes from the workshops by present-

ing them to the participants for review; another is the use of a laptop for direct notations during the development working sessions and a structured filing system for all project documentation and data files.

The reliability and validity of the work performed within the research project are also continuously reviewed. The review is both internal by the cross-functional development team during concept development team and by the LTU research group, and external through regular issuing of project progress reports to project stakeholders.

## **4 Research Process**

This research has been conducted through a joint industrial research project eMaintenance 24/7 (referred to as 'the eMaintenance-project'), performed in close cooperation between the Division of Operation & Maintenance Engineering at Luleå University of Technology (LTU) and the Aircraft Services Division at Saab Aerotech. The project has been financially supported by the Swedish National Aeronautics Research Programme (NFFP) No. 4 and Saab Aerotech. The NFFP4 project was conducted during the years 2006-2009.

Previous to the eMaintenance project, the author of this thesis performed his initial research, as a Ph.D. student at the Division of Quality & Environmental Management at LTU, within the project, 'User Information and Usability in Complex Technical Systems' in the preceding NFFP 3-programme (referred to as the NFFP3-project) which was conducted during the years 2001-2004, with a one year extension to 2005. The author's research done within the NFFP3-project is presented in the Licentiate thesis 'Development of User Information Products for Complex Technical Systems' (Candell, 2004).

The purpose of the NFFP3-project was to explore and describe the development of stakeholder-based information products for complex technical systems in general, and for JAS39 Gripen fighter aircraft in particular, in order to contribute with knowledge to the area of user information development. To fulfil the purpose a case study supported by a literature study was made. The case study focused on a modern combat aircraft, which is considered as a highly complex system with stringent requirements on user information support. A development methodology for user information products was adapted and then applied and studied during the development of a demonstrator.

Results from the NFFP3-project has directly and indirectly been utilised within the eMaintenance-project, which partly can be seen as an further development of the preceding NFFP3-research.

The main objective of the research within the eMaintenance-project presented in this thesis, has been to demonstrate the usefulness of ICT-applications for development and provisioning information support services for the operation and maintenance 24/7 of geographically distributed aircraft systems.

The research process is built on four main phases: I) literature study of theories related to information support, eMaintenance and some other relevant knowledge domains; II) a case study related to information support services, eMaintenance and the application domain of aviation; III) development of a

information support concept using eMaintenance; IV) compilation, assessment and dissemination of performed activities and obtained results. See Figure 8. These phases are described in more detail in the following sections.



*Figure 8. Research process phases.*

#### **4.1 Phase 1: Literature Study**

The literature study for the research was aimed at collecting data about how system-oriented, process-oriented, lifecycle-oriented and service-oriented information products for a complex technical system could be designed. As the study continued, focus moved towards methodologies and tools that could be adapted or constructed to support the development information support solutions for complex technical systems in general, and in an aviation context in particular. These data were collected from different books, scientific journals and trade journals as well as databases.

The activities to achieve the objectives of this first phase were: I) literature study (see e.g. the papers appended to this thesis and project documentation); II) networking (e.g. manufacturers, users and customers within Swedish military aviation, healthcare, the power production industry and the process industry) and III) participation in conferences, seminars, forums, etc., such as the Centre for Maintenance and Industrial Services (CMIS) and the Scandinavian Organisation of Logistic Engineers (SOLE).

#### **4.2 Phase 2: Case Study**

The focus for a case study is determined by the purpose of the research. The origin of this research problem is the development and provision of information support for complex technical systems used in environments where there are very high requirements on safety, credibility, and which are connected to an aviation context.

Different case study subjects were considered that might be suitable regarding relevance and validity, and there are obviously many complex and critical



systems that may be of interest, e.g. process or power industry systems and public transportation. The choice fell finally on the JAS39 Gripen system and its aviation context, which fulfilled the requirements mentioned above and was regarded as a representative example. This choice was also influenced by the requirements on practical access to different types of qualified data, as well as limitations of the project regarding time and resources, which excluded other aircraft candidates manufactured or operated abroad.

The empirical data from the JAS39 Gripen system were collected for the purpose of studying the application of the suggested development process, that were adapted to support the development of information support services and products for complex technical systems in general, and JAS39 Gripen in particular. These data were mainly collected in the forms of requirements, notes and other statements not only from workshops and interviews, but also from documents.

The application case is the concept development of an information support solution within the research project. Stakeholders that supply the requirements on the concept development were selected with respect to the purpose of the study and the given practical limitations of the research project. Personnel at Saab Aerotech, with the participation of the author and the rest of the research team, performed the concept development.

### **4.3 Phase 3: Concept Development**

The objective of the concept development phase was to develop and assess solutions (e.g. technologies, methodologies and tools) that address some of the identified gaps related to the development of Information Support Solutions and eMaintenance, focusing on aviation.

To achieve the objectives of this phase, the following activities were performed: I) an identification of critical information and information support requirements of customers and providers; II) an identification of characteristics of ICT-related methodologies and technologies suitable for fulfilling the information support requirements of customers and providers; III) adaption and development of an approach for the development and provision of ICT-based information support solutions that satisfy the requirements of customers and providers.

### **4.4 Phase 4: Compilation and Dissemination**

The purpose of the compilation and dissemination phase were to: I) deliver the results from conducted research activities; II) contribute with new knowl-

edge that is valuable for both the academic and the industrial communities and III) establish a foundation for further research.

To achieve the objectives of this phase, the following activities were conducted: I) publishing scientific journal and conference papers, that disseminate the results of conducted activities; II) publishing industrial documents that more specifically treat the issues and results related to aviation and III) compiling and summarizing the results, e.g. in this doctoral thesis.

Furthermore, in order to establish proper information logistics between the project members and other related stakeholders, a research web portal has been utilized. The portal provides functionality, e.g. content management, site security, calendar and content syndicating through RSS and e-mail, which has been used for dissemination of research-related information and results in this research, available at <http://88.131.16.83/sites/e-Maintenance>.

## **4.5 Outcomes**

The outcomes from the conducted activities of the phases mentioned above were delivered through the following products: I) project-internal documents, archived and available through formal diaries at Luleå University of Technology, Saab Aerotech and VINNOVA; II) Internal Saab documents; III) Scientific conference and journal papers; IV) articles in industrial trade journals; V) seminars and workshops; and VI) this doctoral thesis.

## 5 Description of Appended Papers

### Paper I

*Candell, O., Karim, R. and Söderholm, P. (2009). eMaintenance: Information logistics for maintenance support. Journal of Robotics and Computer-Integrated Manufacturing. (Published)*

The purpose of this paper is to present some results from a joint academic and aerospace industry research project, describing requirements and expectations that are important in a global support environment, and also to propose some central components in an eMaintenance framework (see Karim (2008) for a more detailed discussion) that integrates maintenance and ICT perspectives.

This paper focuses on a concept for ICT-based products and services for maintenance of modern aircraft. However, it is believed to be extensively applicable to similar challenges regarding maintenance of other complex technical systems, e.g. within the transport, process and power industries, as well as telecom and health care. The paper presents requirements and needs regarding the mentioned products and services that are important for both suppliers and customers (operators) of modern aircraft systems in a global support environment and proposes some central components of an information logistic concept for maintenance purposes, called eMaintenance Management Framework (eMMF), that integrates maintenance and ICT perspectives to address the challenges presented above.

The positive impact of eMaintenance is to be expected on two levels. One is the 'maintenance micro-level', where eMaintenance will serve as a performance support that facilitates hands-on execution of maintenance tasks by technicians, mechanics and support engineers, by providing a reduced number of interfaces to information sources. The other level is the higher 'maintenance macro-level', where eMaintenance will support managerial maintenance planning, preparation and assessment, enabling information driven maintenance and support processes, and aircraft fleet-efficiency. The impact of an eMaintenance implementation on aviation maintenance is of considerable potential as it enables a more efficient use of existing digital product information and design data over the whole life cycle.

## **Paper II**

*Karim, R., Candell, O. and Söderholm, P. (2008c). Development of ICT-based Maintenance Support Services. Journal Quality in Maintenance Engineering. (Published)*

The purpose of this paper is to provide a description of a taxonomy for an eMaintenance Management Framework (eMMF) that is based on a service-oriented approach, in order to facilitate the development of ICT-based maintenance support services aimed at actors within the maintenance process related to complex technical industrial systems

This paper describes the maintenance process related to military aircraft in Sweden. It also presents a framework for development of eMaintenance solutions based on a service-oriented approach. The paper also presents taxonomy for an eMaintenance Management Framework (eMMF), based on a service-oriented approach. The eMMF aids in the identification and establishment of collaborative and interconnected maintenance support services, tailored for specific maintenance actors and their activities. Based on the experiences from the prototype development process, it can be concluded that the proposed eMMF can be utilized for identification and development of maintenance support services realized as SOA-based services.

## **Paper III**

*Karim, R., Candell, O., and Söderholm, P. (2009). eMaintenance and Information Logistics: Aspects of Content Format. Journal of Quality in Maintenance Engineering. (Published)*

The purpose of this paper is to describe aspects of content sharing within an eMaintenance solution, in order to merge the two areas of maintenance and ICT in a content management perspective. Hence, the paper describes information logistics related to maintenance from a content management perspective. It provides an overview of some of the existing efforts related to maintenance content management with focus on content format.

Most of the existing eMaintenance concepts seem to suffer from a gap between data processing and knowledge management. This situation can be caused by too great a focus on data collection, without any clear identification of the stakeholders for whom the data is collected. Hence, it should be emphasized that a mature eMaintenance concept should: I) focus on the content and the process of sharing content rather than on data and data processing and II) provide an output-based information strategy, which means that the stakeholders' needs for information should determine the extent of the managed content.

## Paper IV

*Söderholm, P., Karim, R. and Candell, O. (2008). Design of Experiment and Simulation for Identification of Significant eMaintenance Services. (submitted to a journal)*

The purpose of this paper is to describe a methodology and a supporting toolbox that identify information-based maintenance support services using an evaluation of the services' impacts on the effectiveness of complex technical systems.

The study shows that ICT for maintenance support impacts on a number of Measures of Effectiveness (MoE). For the example used in the paper these MoE are e.g. Risk Of Shortage (ROS), Risk Of Shortage with Time tolerance (ROST), Probability of No Backorders (PNB). Some parameters that are affected by the use of ICT and impact on these MoE are: the turnaround time needed to carry out preventive maintenance tasks and the time required to order and transport an item or a system from the supporting station.

The applied methodology and its supporting toolbox seem to support the identification of maintenance support services enabled through ICT-applications. However, there are some challenges to apply traditional DoE principles in simulation context, since the number of factors and responses tends to be quite large. These challenges can partly be managed by the use of fractional factorial designs and, as in the paper, fold-over designs. In addition, there are some aspects that selected software tools have to manage, e.g. regarding heterogeneous development environments, scalability and data management.

## Paper V

*Candell, O., Karim, R., Söderholm, P. and Kumar, U. (2009). Service-oriented information logistics as support to intelligent transport services. (Published).*

Today's society is dependent on an increasing volume of transportation services, which contributes to escalating requirements on economy, dependability, safety, and sustainability of applied transportation systems. When dealing with complex transportation systems with long life cycles, maintenance is fundamental to ensure these critical requirements. The increasing requirements and the technological development have also led to the emerging approach of eMaintenance, which applies innovative Information & Communication Technology (ICT) to achieve effective information logistics for maintenance purposes. The paper describes the role and development of service-oriented eMaintenance solutions to enable intelligent transportation services and some related research efforts within railway and aviation.

At a national level, information exchange in the context of intelligent transport services and systems the information logistics is essential, since information logistics addresses the aspects of when to deliver; what to deliver; how to deliver; and where and why to deliver. The establishment of information logistics based on SOA and SOI increases the adaptivity of the inherent information services and enables the transportation system's capability to provide intelligent services that are context-aware and situation-aware by combining information available from different sources in order to meet the requirements of the transport system stakeholders.

## **Paper VI**

*Candell, O. and Karim, R. (2008). eMaintenance - Information Driven Maintenance and Support. (Published).*

An essential central problem with maintenance and support of aircraft and other complex technical systems is to manage the ever-increasing information flow and system complexity. Both military and commercial operators need to reduce downtime and one way to do this is to speed up the turn-around time for scheduled and unscheduled maintenance, or even better, to reduce the need thereof by implementing condition based maintenance.

eMaintenance has the potential to improve the management and performances of activities related to the maintenance process, and improve the dependability, safety and life cycle cost through the application of Information & Communication Technology (ICT) throughout the maintenance and support processes. This paper presents some results from a joint academic and aerospace industry research project, describing requirements and expectations that are important in a global support environment, and propose some central components in an eMaintenance framework that integrates maintenance and ICT perspectives.

The conclusion is that an eMaintenance platform (eMP) structured, designed, and implemented from a service-oriented perspective with focus on the business process, increases the ability to fulfil the requirements such as context-awareness, situation-awareness, seamless information integration between processes (e.g. operation and maintenance), improved knowledge-sharing, flexibility, extensibility and cost-reduction. Further, we can conclude that SOA as an approach and Web Service as a technology can be utilized to implement service-oriented maintenance services.

## **6 Description of Concept Development**

### **6.1 Maintenance and Support Related to JAS39 Gripen**

Cues to understanding the design of the complex system that was to become the Gripen fighter aircraft can be found in the innovative thinking behind the project in the early 1980s. The fighter project was based on the need for a multi-role (or swing-role) airborne platform. The seemingly contradictory needs were to have an aircraft and support system with performance superior to its predecessors, but to make it cheaper to produce and easier to operate. (Sandberg and Strömberg, 1999).

During the 1980s and 1990s the technological development led to an increased focus for Swedish combat aircraft on availability performance and life cycle cost. This has had impact on the accompanying requirements for increased competence development regarding reliability and maintainability at the organization developing the aircraft. It also required development of the monitoring processes, of operational performance and support cost, to improve the work with continuous improvements during the operational life cycle phase of the aircraft. (Kontonoya and Sommerville, 1998; Sandberg and Strömberg, 1999).

The preceding generation of combat aircrafts (the third, represented among others by Mig-29, F-16, F/A 18 and JA37 Viggen) does utilize computers, but then together with separate digital systems. The platforms are also large and heavy and this increases the operating costs. The lack of integrated infrastructure also makes it difficult to introduce new functionality and utilize new technology, which in turn accelerates the aging of the system. (Lorell et al., 1995).

The Gripen project aimed at breaking the trend at the time of increasingly larger and, especially with respect of the operating and maintenance costs, more and more expensive aircrafts. This was to be done by exploitation of new technology.

The result was an aircraft that was built with new materials, highly computerized and had an information management capability that eases the pilot's workload. As such, Gripen was the first of the so called fourth generation aircrafts, (Hewson, 1995; Ahlgren et al., 1998; Griffiths, 2000; North, 1999).

The fourth generation combat aircrafts (4G) are defined by Lorell et al. (1995) and Ahlgren (1998) as system aircrafts with supersonic performance, digital infrastructure and fully integrated computer systems that utilize a common

database through standardized interfaces. In the Gripen case this comprises more than 20 subsystems for flight control, weapons, hydraulics, display and manoeuvring and others; sub-systems that all are capable of supplying, transmitting and receiving information.

The communication is carried out through data busses and is administrated by a central systems computer. Together, they build a system with theoretically an infinite number of possible combinations. The building principle of a system-of-systems supplies an immense potential for development, but also an extremely complex aircraft system.

When the perspective is broadened to comprise the entire weapon system it will, besides the aircraft, include parts of the basing system, air traffic and combat control systems and the support system with its functions for training, operation, maintenance and material support. All of these systems are in turn to be regarded as complex, to great extent computerized and to different degrees integrated, or interfacing with the Gripen aircraft system.

## **6.2 JAS39 Gripen and Information Support**

Regarding information support for the Gripen aircraft the existing, mostly paper based information (or the publication suite, as it is often called), is a vital part of the support system. The development of the present Gripen publication suite is originally formed by a number of key factors. One was a decision to create a generic role of an aircraft technician, instead of several cadres of technicians specialized in different disciplines like engine, avionics, weapon and so on. A solution mainly enabled by the new technical means to radically increase the aircraft's built-in-test. This was driven by the need to lower the operating cost and simplify the operation, together with tactical demands of the wartime operation on dispersed bases (Sandberg and Strömberg, 1999). Another aspect was the goal to keep the Swedish model of using conscripts as aircraft mechanics.

These prerequisites in turn created requirements on the design of the technical system, i.e. the aircraft, and the maintenance support. As mentioned, an increased use of, among other things built-in-test, was to simplify and make Flight Line Operation (FLO) and operational level maintenance more effective with less resources. The Swedish concept of dispersed bases for operations put a unique demand on maintenance and reliability (North, 1999), and together with the new technology applied it new needs and requirements for information support.



### 6.3 Information Support Concept Development

Candell (2004) presents a development method for user information products, based on a case study of the JAS39 Gripen. It contains preliminary requirements elicitation structured in affinity diagrams and a small-scale application in an adapted QFD-matrix. QFD is central to the approach, as it provides support for the important move from high level customer needs to more detailed technical requirements (Akao, 1992; Barnett and Raja, 1995). The results showed that the QFD methodology, matrix and affinity diagrams, combined with the system view, could support the development of stakeholder based information products for complex technical systems.

One of the existing frameworks that approaches information support related to maintenance from an ICT-based, service-oriented perspective is the eMaintenance Management Framework (eMMF), presented in Paper II and by Karim (2008). eMMF consists of two parts: the eMaintenance Management Model (eMMM) and the eMaintenance Platform (eMP), see Figure 9. The eMMM is a package of Processes, Roles and Repositories that are required for managing the eMP. The eMP, on the other hand, is a Service-Oriented Architecture (SOA)-application aimed at providing its stakeholders with tailored information pivotal for making decisions on the choice of appropriate maintenance activities. The eMP's purpose is to extract all the information necessary for a certain maintenance activity, analyze, synthesize, and package it into a maintenance process relevant for the maintenance activity.

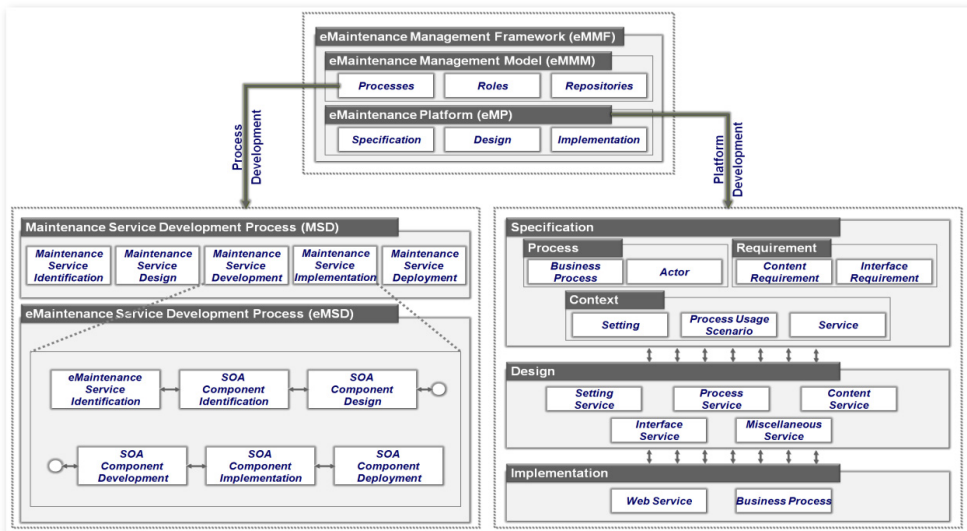

Figure 9. Structure and Elements of the eMMF.

The Maintenance Service Development (MSD) consists of five interconnected phases: Maintenance Service Identification, Maintenance Service Design, Maintenance Service Development, Maintenance Service Implementation and Maintenance Service Deployment. The aim of the MSD is to provide a generic process for development of maintenance support services.

The process model for eMaintenance Service Development (eMSD) consists of the six phases: eMaintenance Service Identification, SOA Component Identification, SOA Component Design, SOA Component Development, SOA Component Implementation and SOA Component Deployment. The objective of eMSD is to realise the identified ICT components, which have broadly been identified in MSD, with a service-oriented approach. It is initiated during the Maintenance Service Development and contributes to Maintenance Service Deployment.

During the eMaintenance Service Identification the context and correlation of information services that support maintenance actors to perform their activities are identified and described. Further, during the SOA Component Identification phase, the components that are needed from an ICT-perspective are determined. In the SOA Component Design and Development phases, it is described how the candidate components can be composed and materialized, but also what technologies to use. In the SOA Component Implementation phase the service components are implemented in the intended maintenance support service. Finally, in the SOA Component Deployment the implemented services are delivered for in-service use.

The eMP is divided into the three levels: Specification, Design and Implementation (see right hand side of the bottom part of Figure 9). The Specification Level contains all the information necessary for performing maintenance activities. It is realized in various ways using notations, such as text and models. The Design Level identifies design components, which are realized as SOA-components. Finally, the Implementation Level materialises the SOA components into Web services and business processes orchestrated for the needs at hand.

To evaluate the proposed process for development of information support solutions for complex technical systems, parts of a concept development process have been performed. During the evaluation parts of the QFD requirement identification and analysis from the NFFP3-project (see Candell, 2004), together with requirements and process parts (i.e. MSD) of the eMMM (described in Papers II and IV) have been used. The concept development focuses on the process for development of an information support concept related to JAS 39 Gripen.

Below follows a summary of an adapted ILS development process studied within the case study. The ILS process include the different parts, which may be performed iteratively within an particular process instance (i.e. a ILS development process adapted to a particular project and developing organisation), see Figure 10.

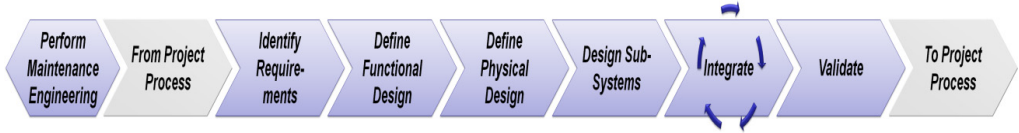

**Figure 10.** An example of an adapted ILS development process for an aircraft maintenance system (Saab Aerotech, 2009a).

Looking into the ‘Develop sub-systems...’ sub-process one will find several sub-system (also referred to as an ‘ILS-element’) of the developed maintenance system covering the design of maintenance resources. It is notable that immaterial resources such as specifications, i.e. information about packaging, handling and transportation (PHS&T) also are regarded as maintenance support resources, see Figure 11. In the presented Saab example, one will also find a ‘Information Management’ ILS-element. This is an aviation industry adaption aimed at coordination the design of solutions for the management of the increasing amount of maintenance related data and information connected to a modern aircraft.

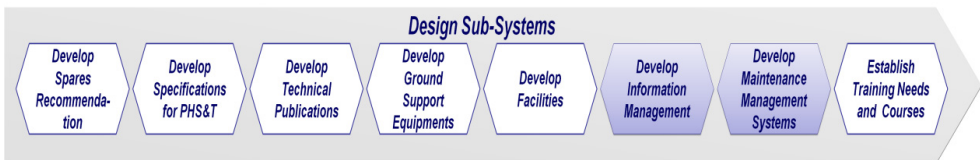

**Figure 11.** The ‘Develop Information Management’ sub-process within the ILS development sub-process ‘Design sub-systems’. (Aerotech, 2009a).

The ‘Develop Information Management’ sub-process aims to apply an integrated approach on development of information services, that enables the management of maintenance related data and information. See Figure 12.

The primary context for the concept development was the above presented ‘Develop Information Management’ sub-process. The sub-process in turn, existed within an ongoing ILS development in its early stages at Saab Aerotech for the next generation JAS 39 Gripen maintenance system, which provided the overarching case study context.

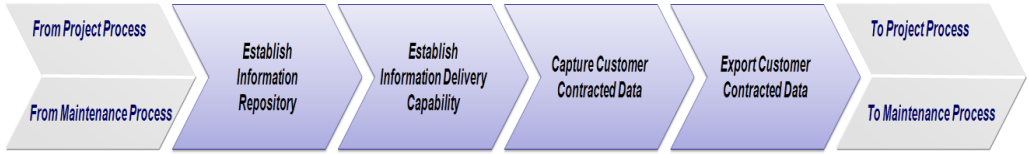

**Figure 12.** The ‘Develop Information Management’ sub-process (Saab Aerotech, 2009a).

In summary it can be noted that ILS standards and general ILS process descriptions, even when adapted for a particular industrial application as in the presented example, only discuss and provide general guidelines of what kind of process activities that are suggested. Though, there is little or no detailed guidelines on the application regarding how to things are to be done provided in the studied ILS process, e.g. suggestions regarding methodology or tools for the process activities.

The concept development is limited to ICT-based information support to a generic maintenance process, and not on development of eMaintenance framework.

The utilised Maintenance Service Development Process (MSD) (see Karim, 2008), consists of five interconnected phases: Maintenance Service Identification, Maintenance Service Design, Maintenance Service Development, Maintenance Service Implementation, and Maintenance Service Deployment. The aim of the MSD is to provide a generic process for development of maintenance support services.

As the purpose of this research is to describe how providers of support solutions can develop and provide effective information support solutions, the nomenclature of the original MSD is adapted for clarity and to better reflect the purpose and delimitation of this research. As information support services are a part of maintenance support, the phases are therefore referred to as ‘Information Support Service’ (instead of Maintenance Support Service). See Figure 13.



**Figure 13.** Adapted Maintenance Service Development Process (MSD), (Karim, 2008). Phases 1-3 applied within information support concept development

Implementation of information support service (i.e. how the service components are implemented in the intended information support service) or information support service deployment (i.e. the execution of delivery and deployment of ICT-service components to an intended context, e.g. at a specific customer) is not included in this thesis, but is described in Candell (2004) and Karim (2008).

In this research the development of two demonstrators was realised as a set of ICT-services based on SOA-architecture, which are composed to an application for use from a Portable Digital Assistant (PDA)-adapted interface. (Candell, 2004; Karim, 2008).

### **6.3.1 Information Support Service Identification**

During the phase 'Information Support Service Identification', services that are needed by a customer or user organization, and can be provided by a supplier organization through a maintenance solution, are identified from a business perspective and not a technological perspective. One example in the context of aviation is the question of on-site support services to the operator.

The service identification activities aim at analyzing and evaluating from a both a provider and a customer perspective. From the customer perspective, the analysis should focus on whether the services add value in their business processes. From the supplier perspective, the objective is to analyze the pre-requisites and capabilities that need to be establish in order to provide the identified services.

In order to evaluate the ISD process a number of activities have been conducted to elicit maintenance-related requirements in relation to the concept development, including literature study, workshops, interviews, and document studies. Based on the data collected within these activities, the maintenance process related to the Gripen has been mapped (see Figure 14), which is described in Papers I, II and Karim et al., (2008).

In addition, some of the overarching requirements that some of the potential customers of Gripen have stated formally have been identified and related to the mapped maintenance process. This mapping can be based on formal textual and graphical modelling notations.

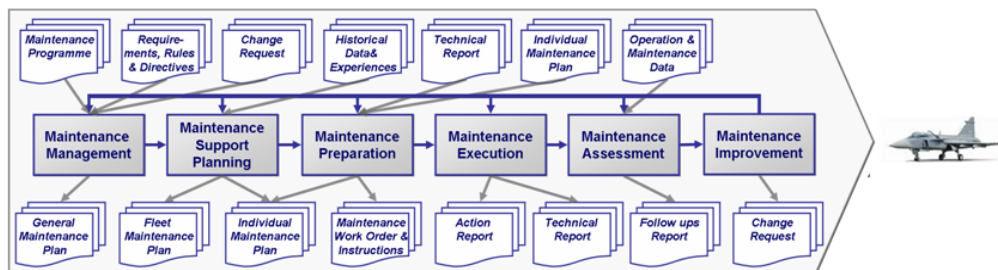

Figure 14. Information managed within the maintenance process related to JAS39 Gripen (Karim et al., 2008b)

Important considerations during the process mapping and identification of critical information and information support requirements of customers and providers are:

- Requirements need to be primarily collected, derived and associated from service and process-oriented perspective, and secondary from a functional point of view on the system.
- Perform process mapping and requirements collection considering the system during all (applicable) phases of the system lifecycle
- Utilisation of a generic maintenance process (or adaption thereof) as point of departure and reference model for process mapping, collection and analysis of requirements. Maintenance process consisting of:
  - Maintenance Management
  - Maintenance Support Planning
  - Maintenance Preparation
  - Maintenance Execution
  - Maintenance Assessment
  - Maintenance Improvement
- Great consideration of requirements on maintenance support.
- Use scenario and use-case techniques
- When motivated use (standard) modelling languages for scenario and use-case modelling and documentation. Preferably tools utilized in the design organisation, accepted by both system-of-interest designers and ILS design organisation.

- Consider both the design of the system-of-interest and enabling system
- Considering aspects of the intended use of the system, its integration in the providers and customer’s business and operational context
- Simultaneously consider from both technology and business perspectives.
- If applicable, utilize approach of micro level and macro level information support to stimulate consideration of multiple perspectives on information support services.
- Scenarios and use-cases, preferable performed with cross-functional teams in work-shops, can be utilised for requirement identification and collection. See Figure 15.

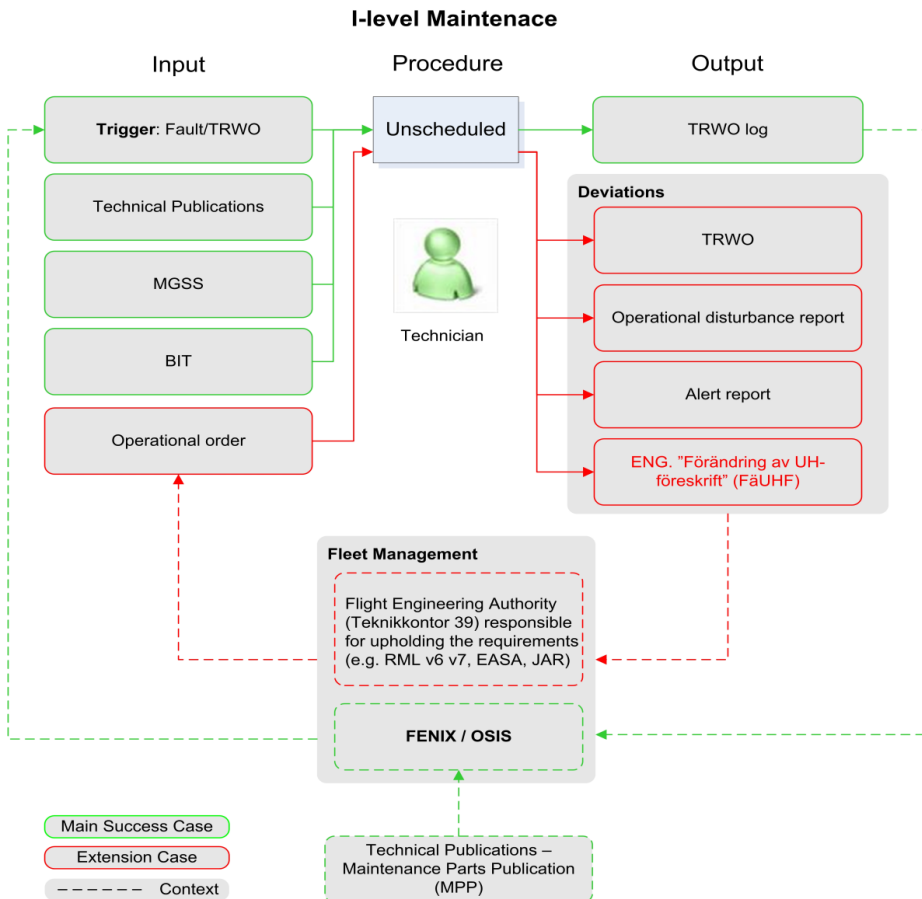

Figure 15. Example of use-case, *Unscheduled I-level maintenance* (Saab, 2009c)

If the scope and complexity of the intended information support concept so require, it can be motivated to apply a model-based simulation methodology in the design of information-based maintenance support services.

Design of Experiment and Simulation for Identification eMaintenance Services provides a highly useful representation (i.e. description) of the maintenance concept, and enables an evaluation of the potential services' impacts on the effectiveness of the system-of-interest. This approach may be utilized within Information Support Service Identification when required.

Paper IV provides a description of a methodology and a supporting toolbox that can be used to identify information-based maintenance support services, consisting of five phases (see Figure 16).

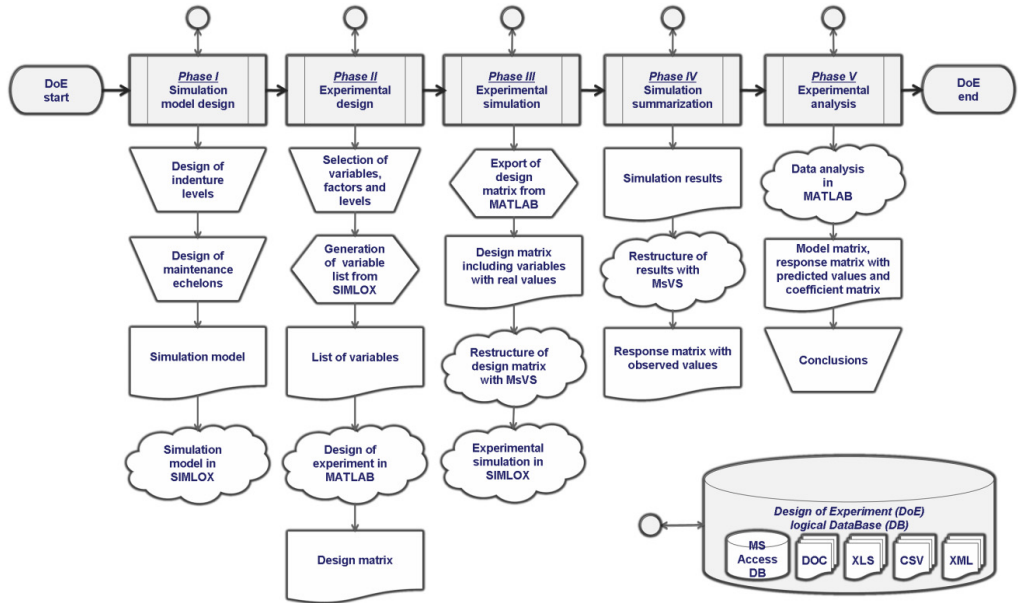

Figure 16. Illustration of the steps of model based simulation methodology and its supporting toolbox.

The methodology and a supporting toolbox that can be summarized as follows:

1. The main purpose of Phase 1 is to establish the maintenance concept, i.e., a description of the interrelationship between the indenture levels and the maintenance echelons. Furthermore, detailed data on the system's inherent items need to be provided, e.g., reliability measures such as failure



rate, Mean Time To Failure (MTTF), and Mean Time Between Failures (MTBF).

2. The purpose of Phase II is to provide a design matrix that is based on DoE principles. One of the first steps in the experimental design is to select the control variables, response variables, nuisance factors, and constant factors.
3. The purpose of Phase III is to execute simulations according to the design matrix, which is exported from Phase II, restructured into a proper format, and imported into the SIMLOX database.
4. The purpose of Phase IV is to compile and correlate the output values of the response variables recorded in the response matrix, with corresponding runs in the design matrix.
5. The purpose of Phase V is to analyse the simulations based on the combined matrix developed in the previous phase. This analysis is conducted using components for matrix algebra. The methodology identifies variables that impact important effectiveness measures for a system-of-interest, and also provides knowledge that could be used to optimize the support system.

The result of the performed research in relation to model-based simulation in combination with DoE is described in more detail in Paper IV.

### **6.3.2 Information Support Service Design**

The purpose of the Information Support Service Design phase is to establish a conceptual model for development and implementation.

In the Information Support Service Design phase additional use-cases and expansion of use-cases from the previous phase, can be helpful to capture and derive additional requirements that will drive the development of information support services. Well defined use-cases within the design phase will support:

- Identification of additional requirements regarding collaborative work between different stakeholders.
- A more explicit definition of the value expected from the services.
- Description of generic operational level activities that need information support.
- Correct level of requirement details to support development.

- Prioritisation of subsets of requirements in order to identify a minimal solution and drive iterative development.
- A systematic approach to ensure the correct design, implementation and verification of requirements.
- Provide valuable and easy understandable documentation for communication within and between the development teams, as well as with other stakeholders.

Each use case may preferably be described at a high summary level and identifies generic input and output information requirements, as well as interdependencies that enables the user to reach the main success end condition and its possible extensions. Defined use-cases may be grouped into packages for structure and ease of understanding, e.g. maintenance, storage management and operation. See Figure 17.

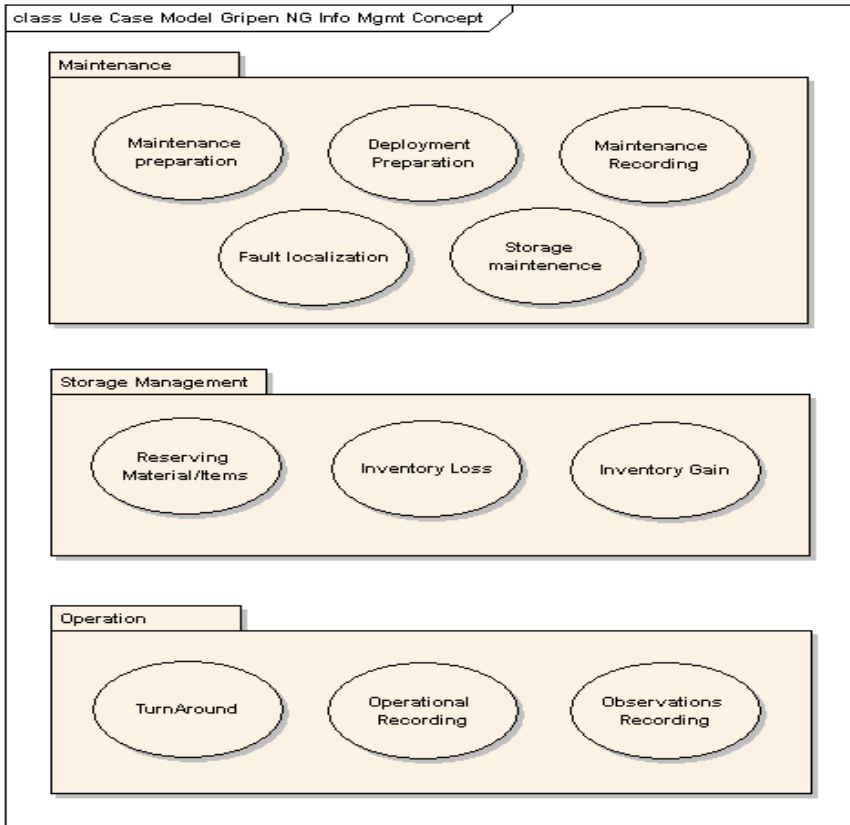

Figure 17. Example of use-cases grouped into packages (Saab, 2009c).

The output and result from the Design phase is a description and specification of what the candidate services are, and how they can be developed.

This is preferable a specification with a general description of the concept and guiding principles for the support concept, including information support, as part of the maintenance system. Requirement databases, digital models and simulation models are to be considered as integrated parts of the specification.

### **6.3.3 Information Support Service Development**

This phase describes how the candidate components can be composed and materialized, and also what technologies should be used.

Results from the concept development were consolidated in a specification (Saab, 2009b).

### **6.3.4 Information Support Service Implementation**

In this phase the service components are implemented in the intended information support service. This phase was not within the scope of the performed research.

### **6.3.5 Information Support Service Deployment**

The Component Deployment phase results in the delivery and deployment of the ICT-service components to the intended context, e.g. at a specific customer. This phase was not within the scope of the performed research.



## 7 Results

*This chapter presents the main results of related to the Research Questions (RQ) this research i.e.: I) a definition of system-oriented, service-oriented, process-oriented and lifecycle-oriented eMaintenance solutions; II) an identification of critical information and information support requirements of customers and support providers; III) an identification of ICT-related methodologies and technologies suitable to fulfil the information support requirements of customers and support providers; and IV) an approach for development and provision of ICT-based information support solutions that satisfy the requirements of customers and support providers.*

### 7.1 Result I Related to RQ1

*A definition of system-oriented, service-oriented, process-oriented and lifecycle-oriented information support solutions.*

In this research eMaintenance is defined within the maintenance support requirements that ensure that the maintenance process is aligned with the operation and modification processes to achieve business objectives, through proper information logistics and provision of information services by utilization of Information & Communication Technology (ICT) in the context of complex technical systems and their support systems. Hence, from a support perspective, eMaintenance solutions provides ICT-based information support services, which can be utilised by support provider and support consumer, during all different phases of a system's lifecycle, e.g. detailed design, utilisation and retirement. See Papers I and II for further discussion of this definition.

Hence, an information support solution within an eMaintenance framework can be described as an ICT-based solution that aims to enable and facilitate the offering and provisioning of a set of required information support services. The purpose of these services is to provide Information Support related to: maintenance; monitoring; collection; recording and distribution of real-time system health data, maintenance-generated data, design data as well as other decision and performance-support information required for maintenance purposes. The services are aimed at actors within the maintenance process, independent of organization or geographical location, twenty four hours a day, seven days a week (24/7).

## 7.2 Result II Related to RQ1

*An identification of critical information and information support requirements of customers and providers.*

The definition of eMaintenance provided above is closely related to critical information and information support requirements of customers and providers in the context of complex technical systems. Hence, the context and related overarching requirements lead to a definition that is system-oriented, process-oriented, lifecycle-oriented and service-oriented. These features of the definition can be related to stakeholder requirements classified into different categories. One useful classification is into different levels, e.g. a 'micro-level' and a 'macro-level'. See Papers I, II, III, Candell (2004) and Karim (2008b))

The system-orientation is based on requirements on a necessary integration of the system-of-interest and the enabling systems.

Micro-level requirements are critical requirements on information support that are related primarily to performance-support that facilitates execution of activities hands-on the system-of-interest and its components by e.g. technicians, mechanics and support engineers. These actors perform activities that primarily include interaction with items on a sub-system, equipment or component level. These actors require a reduced number of interfaces to information sources, role adapted, situation adapted and context adapted information, improved fault diagnosis, knowledge sharing and automated or facilitated procedures for technical administration; see Papers I and II.

The micro-level requirements are mainly related to the process phases 'Maintenance Execution' and 'Maintenance Assessment' of the maintenance process. Information support for activities within these phases often have stringent requirements on safety and usability, as they may have direct impact on human safety and on critical functions of a system-of-interest (e.g. airworthiness and system safety). The activities performed directly on the system-of-interest are also executed by different types of human resources, and in a great variety of environments and contexts. Micro-level information support have often interdependencies with physical assets and material resources e.g. facilities, personnel, spares, tools and consumables. Identified critical micro-level requirements (see Table 3) are described in Papers I, II and Candell, 2004).

Macro-level requirements are critical requirements on information support that primarily are related to information support on a total system level that considers both the system-of-interest and the enabling systems, e.g. for the phases maintenance management, planning, preparation and assessment of

the maintenance process, as well as requirements related to development, production and continuous improvement of information support, other support resources and the system-of-interest. See Papers I and II.

These macro-level requirements are related to the need to enable and facilitate information-driven maintenance and support processes, as well as maintenance planning and maintenance programme evaluation and modification. Macro-level requirements are to a great extent related to the need for information support to Operational Monitoring (OM) and Life Cycle Management (LCM). Figure 18 illustrates the generic information flows identified for generic OM and LCM workflow, which generates macro-level requirements on an eMaintenance solution.

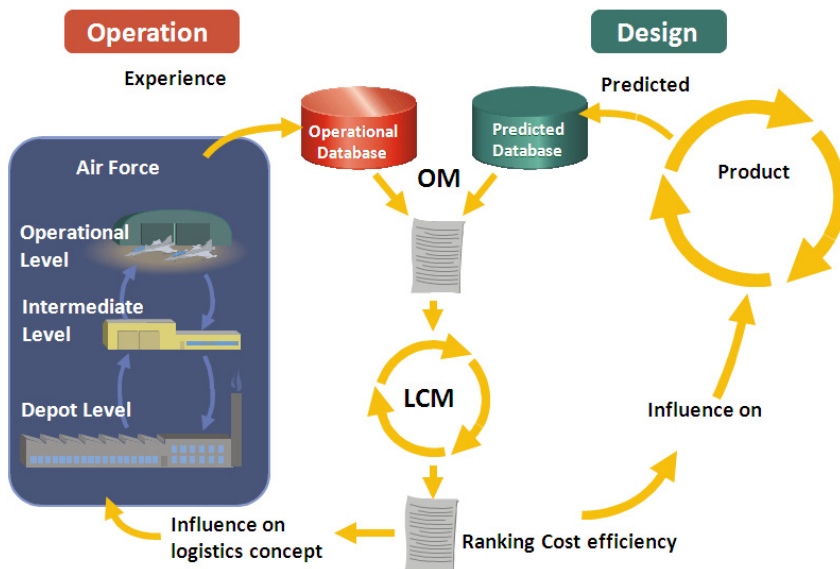

**Figure 18.** Illustration of information flow (yellow arrows) for Operational Monitoring (OM) and Life Cycle Management (LCM), adapted from Sandberg and Strömberg (1999).

The macro-level requirements related to OM and LCM have been emphasised by business solutions such as Performance-Based Logistics (PBL), where contracted Key Performance Indicators (KPIs) related to both the system-of-interest and the enabling systems have to be monitored in order to pinpoint the drivers of ultimate system effectiveness. These requirements on what kind of information to manage is exemplified in Figure 19:

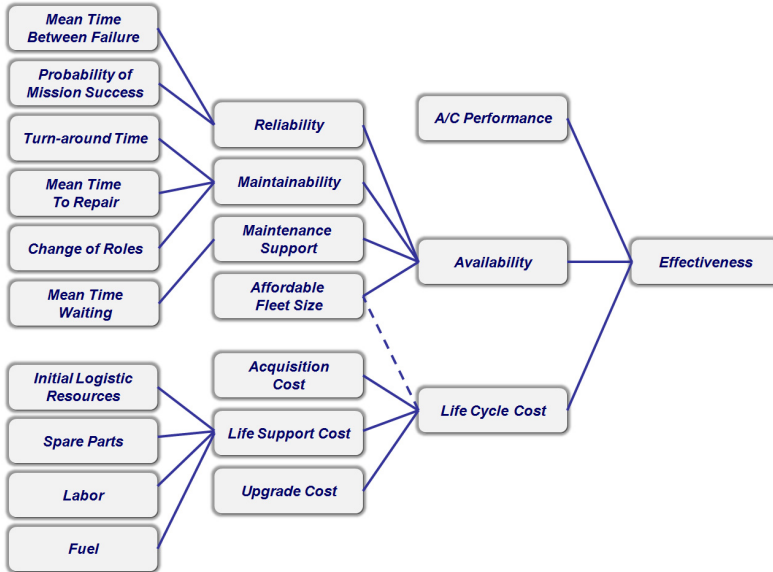

**Figure 19.** Important requirements related to system effectiveness and LCC.

Critical requirements identified in the Maintenance Preparation phase, are related to the preparation of both tangible, material resources (e.g. personnel, facilities, spares, tools and consumables), and intangible resources in the form of information and knowledge.

Information support on the macro-level is therefore in many cases identified as interdependent with information systems beyond the information support products and services, for access and exchange of information and data from e.g. Supply Chain Management (SCM) information systems and related business processes. Identified critical macro-level requirements are summarised in Table 3.

Beyond the presented micro and macro categories of requirements, there are also a number of other critical requirements that can be described as mainly related to general ICT-aspects of information support in the context of complex systems with long life cycles (see Papers I, II and III). Among these are requirements that reflect needs for standardization of information and data formats, protocols, specifications and models. One important aspect of this is that information support concepts and application of new ICT-solutions within industry need to be both based, and capitalize, on international standards for structured product data sharing. Identified critical ICT-related requirements are also summarised in Table 3.



**Table 3.** *Critical requirements on information and information support*

<b>Requirement on information and information support</b>	<b>Micro-Level</b>	<b>Macro-Level</b>
Facilitate Performance-Based Logistics (PBL) through provision of context-adaptable support to actors within the maintenance process (e.g. for OM an LCM)	X	X
Coordination and integration of information production and information consumption processes at different phases of the maintenance process, and over the system-of-systems (i.e. both system-of-interest and its enabling systems) lifecycle.	X	X
Coordination and integration of tests, diagnostics and prognostics for condition-based utilisation, corrective and preventive maintenance, as well as support at different maintenance echelons.	X	X
Coordination and integration of tests, diagnostics and prognostics at different maintenance echelons, in order to achieve improved corrective maintenance and to enhance preventive maintenance.	X	X
Modelling and simulation capability that enable prediction of system performance.	X	X
Capability to model for design, produce and manage, specify and control product and support information, required for activities throughout a complex system's life cycle.	X	X
Standardization of information, data and specifications for computer-based learning and training.	X	X
Accessibility; access control, information security	X	X
Standardization of processes and information related to logistic support analysis (LSA) and integrated logistic Support (ILS).		X
Utilisation of existing digitalised legacy information for integration with acquisition, design, production and provisioning of new digital information.	X	X
Enablement of role, situation and context adapted services for information and information support with high accessibility, e.g. portability and high usability.	X	X
Facilitation of global information support, with 24/7 accessibility.	X	X
Facilitation of configuration control, change management and directive information applicability for both the system-of-interest and products and services included in the enabling system	X	X

### 7.3 Result III Related to RQ2

*Characteristics of ICT- suitable to fulfil the information support requirements of customers and providers.*

The identified characteristics for suitable Information & Communication Technology (ICT) in accordance with RQ2 are summarised in Table 4.

**Table 4.** *Characteristics of suitable ICT artefacts*

<i>Characteristics of suitable ICT</i>	<i>Category</i>		
	<i>Methodological</i>	<i>Technological</i>	<i>Miscellaneous</i>
Process orientation	X	X	
Services orientation	X	X	
Enable establishment of ICT-platforms that support intra and inter organisational processes	X	X	
Enable, align, and facilitate data analysis and information retrieval from heterogeneous information sources	X	X	
Facilitate context and situation adaptation of content to heterogeneous actors' needs	X	X	
Enable standardisation of information content	X	X	X
Increase flexibility in the software architecture of the information support	X	X	
Facilitate co-existence and integration of heterogeneous ICT systems	X	X	
HW and SW that enables standardized information sharing		X	
Capability for analysis of system performance in a lifecycle perspective	X	X	
A framework that merge the process of information services and business-services development, and address the issue of to how to define and describe a structure for service implementation	X	X	X

## 7.4 Result IV Related to RQ3

*An approach for development and provision of ICT-based information support solutions that satisfy the requirements of customers and providers.*

The result connected to RQ3 is a system-oriented, service-oriented, lifecycle-oriented and process-oriented approach to development and provision of ICT-based information support solutions. This approach is intended to satisfy the requirements of customers and providers, and suggests a development process which includes methodologies and tools (see Figure 20). This process is intended to provide a generic process for the development of information support services.



*Figure 20. Suggested Information Service Development Process (ISD).*

The result in terms of the suggested development process is summarised in following sub-sections.

### 7.4.1 Information Support Service Identification

In this phase the collection of relevant requirements on information support should consider both the system-of-interest and enabling systems (see Papers I, II, V, Candell, 2004 and Karim 2008b). Both system should also be approached considering aspects of the intended use of the system, its integration in the providers and customer's business and operational context, and simultaneously from both technology and business perspectives. Quality Function Deployment (QFD) is a methodology that enables transfer of requirements to the design process through matrix diagrams (Candell, 2004). By this application the original needs and requirements of the customer ('what') is systematically transformed into product qualities ('how') through a controlled and traceable process. In order to manage requirements during the whole Information Support Development process, it possible to use requirement management tools such as DOORS and CORE.

In this phase, a business perspective is applied to identify services that are needed by a customer or user organisation, which can be provided by a supplier organisation through a information support solution. In addition to QFD, process mapping can be used as a methodology to identify critical information and information support requirements (see Paper II). It is also pos-

sible to apply model-based simulation methodologies in combination with Design of Experiment (DoE) in the design phase, which enables an evaluation of the potential services' impact on the effectiveness of the system-of-interest (see Paper IV). Examples of supporting ILS-related modelling and simulation tools useful in the identification phase are: SIMLOX, CATLOC, OPUS.

The definition of system-oriented, service-oriented, process-oriented and life-cycle-oriented information support solutions utilized for the information support service identification are presented in Section 7.1 'Result I Related to RQ1'. Critical requirements identified within the performed research are presented in Section 7.2 'Result II Related to RQ1', Papers I-VI, Candell (2004) and Karim et al. (2008b).

### **7.4.2 Information Support Service Design**

In this phase a conceptual model for development and implementation is established. The output and result from the design phase of the information support solution is an enhanced specification and conceptual model for development and implementation. This phase is to be performed from a holistic perspective and aligned within the ILS development process.

The result from the design phase provides a description and specification of potential services and how they can be designed. Examples of useful methodologies that support a system-oriented, process-oriented, service-oriented and lifecycle oriented design approach are: Essential Unified Process (EssUP); Rational Unified Process (RUP); Service Oriented Architecture (SOA); Event Driven Architecture (EDA); efforts from Machinery Information Management Open Systems Alliance (MIMOSA, 2008); ASD Specification S3000L-Logistics Support Analysis, ASD Specification S4000M-Reliability Centered Maintenance (ASD, 2009); and QFD. Examples of supporting ILS-related modelling and simulation tools useful in the design phase are: SIMLOX, CATLOC and OPUS.

Characteristics of ICT suitable to fulfil the information support requirements of customers and providers identified within the performed research, are presented in Section 7.3 'Result III Related to RQ2', Papers I, III, IV and Candell (2004) and Karim et al. (2008b).

### **7.4.3 Information Support Service Development**

In this phase it is described how the candidate components can be composed and materialized, and also what technologies should be used.

Examples of useful methodologies that support a system-oriented, process-oriented, service-oriented and lifecycle oriented development approach are Essential Unified Process (EssUP), Rational Unified Process (RUP), QFD and Use-case modelling.

Examples of generic supporting tools are: System Modeling Language (SysML), Unified Modeling Language (UML), Extensible Markup Language (XML), Web services, RUP (Rational, 2008), EssUP, Service Oriented Architecture (SOA), Event Driven Architecture (EDA). Examples of maintenance specific tools are: Product Life Cycle Support (PLCS) and ASD Specification S5000F-Feedback information.

Useful methodologies and tools identified, and partly used in the concept development, are presented in Papers I-IV, Candell (2004) and Karim et al. (2008b).

#### **7.4.4 Information Support Service Implementation**

In this phase the service components are implemented in the intended information support service.

In the Information Support Service Implementation phase, the context and coordination of information services that support maintenance actors to perform their activities are identified and described. This includes the composition and orchestration of the components that are required from an ICT-perspective. Furthermore, how the candidate components can be composed and materialized is described, as well as the selection of technologies.

In the present research this was done through the development of two demonstrators realised as portable digital assistant (PDA) applications. The first was in the context of an aircraft technician.(Candell, 2004), and the second was an extension including the context of a maintenance planner (Karim, 2008). Examples of methodologies and tools used in demonstrator developments are: QFD, XML, Web services, Windows Workflow Foundation (WWF), Windows Communication Foundation (WCF), RUP, Visual Studio .Net, MS SQL Server, MS Access, MS Source Safe, EssUp and S1000D.

Examples of other supporting tools are: Web services, WWF, WCF, RUP, EssUP, Product Life Cycle Support (PLCS), ASD Specifications S1000D Technical Publications, S2000M-Material management, S3000L-Logistics Support Analysis and S5000F-Feedback information.

Useful methodologies and tools identified, and partly used in the concept development, are presented in Papers I-IV, Candell (2004) and Karim et al. (2008b).

#### **7.4.5 Information Support Service Deployment**

The Information Support Service Deployment phase results in the delivery and deployment of the ICT-service components to the intended context, e.g. at a specific customer.

This phase has not been performed within the present research since it is related to specific business agreements. However, the applied methodologies and tools are intended to facilitate the deployment through easy customisation and integration with existing ICT-solutions.

## 8 Discussion

*This chapter discusses some additional aspects of the findings in the research project. It also presents some suggestions for further research.*

Support solution provider can develop and provide enhanced information support solutions related to complex technical systems by utilisation of Information & Communication Technology (ICT).

In addition to the presented results relating to the research questions presented, there are other perspectives and findings in the research that may contribute to the understanding and utility of the presented research.

*System-oriented, service-oriented, process-oriented and lifecycle-oriented* is referring, with reference to the general meaning of the word 'orientation' as 'lasting direction of thought, inclination, or interest' (Webster, 2009), to the intention of this research to give special attention to the perspectives of services, processes and lifecycle in its approach of the domain of information support solutions.

Maintenance Information support is, in this research and in the context of the definitions above, described as information support services that is a subset of an information support solution, and as a part of the Maintenance Support Resources provides information support to a maintenance process during the life cycle of a system-of-interest and enabling system.

### 8.1 Discussion Related to RQ 1

For the purpose to the presented research, it is important to focus on services from perspective of information, as well as from development perspectives and business processes perspectives across the entire life cycle. It is also necessary to harmonise and integrate the information management activities between different actors within these processes, such as the organisations developing the system-of-interest, enabling systems, as well as sub-suppliers and customers.

It is notable that there are areas of coherent micro and macro requirements. This indicates that there are needs for similar information support content on both levels, though it needs to be adapted to the unique situation and context of the users' role. A result supporting the relevance of the service oriented approach in, general and the Maintenance Service Development process in particular, when establishing information support solutions.

Utilised standards may be specific to industry, but there are also examples of more general utilized standards. From these provider perspectives there are also direct and derived, critical requirement related to the ability to utilise existing digitalised legacy information and to integrate it with the acquisition, design and production of new digital information, and thereby facilitate efficient design, production and provisioning of information support.

The result of the research project may be viewed from two perspectives. One is the knowledge gained from the collected and analysed requirement per se, another is the result and experience of the parts of the suggested process that where applied and evaluated during the collection and analysis of the requirement and their use for concept development.

During the collection and analysis of the requirements in the concept development, it was found that the novel and emerging requirements on enhanced information support services are challenging. Improvement of information support for e.g. fault localization, diagnostics, as well as for OM and LCM, requires complex and coordinated design efforts for optimal utilization of the potential available in modern avionics, software and distributed on-board computer systems. Data and information, may already be available in the avionics system or in on-board computers, it may need to be processed, formatted, declassified or encrypted e t c., and communicated to the outside world in an a way that makes it useful for operative and maintenance purposes within the context of enabling systems.

Though, there is also a lack of formal process support for collection of information support needs and requirements that have impact on both system-of-interest and enabling system, but is neither obviously nor directly addressed to any of them. Within the domain of developers of the system-of-interest, there is a wealth of experience from systems engineering and software development, but there is often less knowledge and understanding of usability requirements and other 'soft' aspects of operation and maintenance processes. On the other hand the developing teams working with enabling maintenance systems, which might be experienced ILS, LSA or reliability engineers, often lack experience from the intricate craft of formal systems engineering and software development. Today production and consumption of information support products and services involves a wide range of stakeholders. Due to inherent differences between hardware, software and human system elements, dependence on computer-based technologies and lack of harmonisation and integration of involved disciplines, there is a lack of coordination and integration of processes and digital data throughout the life cycle, as well



as between processes related to information support within development of system-of-interest and enabling system.

In this research it is found that a consequence of this is that there is also a lack of coordination and integrated efforts for the important work to assure a comprehensive and complete collection of requirements, for the development and provisioning of new and enhanced information support products and services. These requirements are a very important prerequisite for the design and operation of complex system.

The positive impact of information support solutions reflecting considerations of eMaintenance might be expected on two levels. This indicates which domains and contexts, which are of central importance to explore for requirements.

On what be described as a maintenance 'micro-level', information support provides necessary information and serves as a performance support facilitating hands-on execution of maintenance tasks by technicians, mechanics and support engineers. This as provisioning of information support as described in the results presented has the potential to reduce the number of interfaces information sources, improve fault diagnosis (e.g. through improved information integration of system-of-interest and enabling systems), knowledge sharing and automated or facilitated procedures for technical administration.

Another level is what in turn might be described as a 'maintenance macro-level, which is aimed to support maintenance management activities such as planning, preparation, assessment and improvement. This by enabling of information driven maintenance and maintenance support processes, and aircraft fleet-efficiency, e.g. system-oriented, service-oriented, process-oriented and lifecycle-oriented operational monitoring and evaluation of maintenance.

## **8.2 Discussion Related to RQ 2**

By aligning the identification and study of the characteristics of suitable ICT methodologies and technologies, with an maintenance process model and a service perspective over the system lifecycle, a foundation is laid down both for a theoretical generalisation, as well as for the practical relevance and applicability, of the research results.

The MSD process of the eMMF provides a generic process for development of maintenance support services, and facilitates a broad identification of ICT components, that are to be realized in the following eMSD.

Some higher level aspects of characteristics for suitable ICT methodologies and technologies, also emanates from the requirements analysis:

- During the development of Information Support products and services there is a need for guiding long-term strategies (approx 2-4 years) for intended application and utilization of ILS Information Management, for provisioning of information support to a particular complex technical system-of-interest, e.g. in future operational scenarios and considering anticipated technological development. This due to the need for coordination with strategic product planning (i.e. for both system-of-interest and enabling system) and the practical aspect of lead time for planning and implementation of enabling research and technology development.
- There is a need for improved strategies for the deployment process as such, for information support solutions that easily handle the inherent dynamics which is a consequence of 24/7 operation of globally deployed, mobile complex technical system used in an military context.
- In spite of emerging standardization initiative, there is still a need to improve Information Support integration with applicable parts of existing legacy applications, in the aforementioned context, without having to rely on solutions based on expensive, redundant databases and ICT-systems.

Existing business and operative environments for complex technical systems often consist of multiple and poorly integrated legacy information sources. Hence, the chosen methodologies and technologies need to enable and facilitate data analysis and information retrieval from heterogeneous information sources, as well as consider aspects and utilization of information content standards. This is also closely connected to the need for methodologies and technologies that facilitate context and situation adaptation of content to heterogeneous actors' needs.

The coherent impact of identified critical ICT- characteristics on both methodology and technology indicates that it is essential to provide both methodological and technological tools, that support system-oriented, service-oriented, process-oriented and lifecycle-oriented approach when establishing information support solutions.

### **8.3 Discussion Related to RQ 3**

The provision of maintenance and maintenance support is identified as a key element to ensure the dependability of systems throughout their life cycle. Hence, the identification of critical information and information support re-

quirements of customers and providers, need to put great consideration on the maintenance process and requirements on maintenance support.

It is also found that the Information Support Development (ISD) process facilitates the identification of requirements, context and correlation of information services that support maintenance actors to perform their activities that are identified and described.

The presented research identifies a need for formal methodologies and tools that enables more efficient and comprehensive descriptions, modelling and specification of both interfaces between system-of-interest and the planned Information Support solution, as well as of processes for information exchange between operational level, relevant maintenance echelons, suppliers and sub-suppliers.

There is a need for enhanced integration of the system-of-interest, the customer's enabling systems as well as provider ICT-system, regarding data and information exchange, to exploit technological development of maintenance and support related data and information produced internally in a system-of-interest. Methodologies and tools that enable establishment of ICT platforms that support intra-organisational and inter-organisational processes are also essential.

New business models like PBL, and continuously increasing requirements on improved dependability and operational flexibility for complex technical systems, push the trend within the maintenance industry towards more integrated packages of maintenance services. Though, these will not necessarily be provided from one facility or from one organization.

Hence, access to methodologies and tools that support service needs and requirements, independent of organisational structures, is a prerequisite to address the challenge of going from a product-oriented to a service-oriented business strategy such as PBL. A product-oriented strategy relies on transaction/exchange marketing, while service-oriented emphasizes the relation between provider and customer.

A service-oriented business strategy also demands the harmonization of support processes, such as the maintenance process, to the business's core process. The business's core process benefits from being adaptable to the changes in the customers' value-generating process, and the business's supporting processes need to be adaptable to the core process.

In this research the term-pair provider/consumer is used to emphasize that ICT for information support to the maintenance process should adapt a proc-

ess-centric approach, supporting efficient maintenance and support solutions. In a supplier/customer approach, the definition of the organizational boundary is important. Though this is not necessarily an issue of importance for delivery of maintenance information, which to greater extent is dependent on support for intra and inter organisational processes.

The maintenance process has to interact with a number of correlated processes in an enterprise, e.g. business, operation, information, support, and logistics. Hence, a service-oriented information support solution should provide services that can be incorporated and configured to suite these processes. While the requirements on the maintenance process vary over time, the architecture of eMaintenance should be considered and constructed to provide applicability and effectiveness of the information support solution.

Requirements from business environment as well as technological development are continuously changing. This raises need for methodologies and technologies that is flexible and adaptable enough to handle following changes in the both provider and consumer value-generating processes, and their business's supporting processes.

There are existing ICT-related methodologies and technologies identified that can be adapted and applied to satisfy the information support requirements of customers and providers. Generic methodologies that have been identified, utilised and experienced as value-adding in the case study are EssUP and SysML. These are methodologies that are based on a service-oriented and process-oriented approach, and therefore support the required process mapping, service definition as well as facilitate development. EssUP and SysML as also promote the use of scenarios and use-case-modelling which supports requirement collection and identification.

In the work presented in this thesis a methodology has been developed that can be used to identify services that have significant impact on critical measures of effectiveness (e.g. mission success) of a system-of-interest.

## 9 Conclusions

*In order to achieve the stated objective three research questions have been posed. Findings related to these are concluded in this chapter.*

### 9.1 Conclusions Related to RQ 1

The first research question of this research was stated as: what are the critical information support requirements of customers and providers?

The objective of RQ1 is to identify critical information support requirements of customers and support providers for effective development of information support solutions by enhanced utilisation of ICT.

Firstly, it has been noted that there are several existing definition of eMaintenance, both within academic and industrial communities. In this research eMaintenance has been defined as the part of maintenance support that enables that the maintenance process is aligned with the operation and modification processes to obtain business objectives, through proper information logistics by Information & Communication Technology (ICT) utilisation and provision of information services. From a support perspective, eMaintenance solutions provide ICT-based information support services which can be utilised, by support provider and support consumer, during different phases of a system's lifecycle, e.g. detailed design, utilisation and retirement.

A central conclusion is that information support services that are provided by support provider, should be easy to utilise by support consumer, during all different (applicable) phases of a system's lifecycle, in applicable parts of the maintenance process as well as coordinated between system-of-interest and enabling system.

Secondly, in this research several critical information requirements related to information support have been identified. These requirements have been categorised in two levels, i.e. macro-level and micro-level.

It can be concluded that similar critical information support requirements of customers and providers exist on various organisational levels and system levels, in different phases of a maintenance process and in different stages of the system lifecycle. Hence, there is a potential to improve information support processes through establishment of a system-oriented, service-oriented, process-oriented, and lifecycle-oriented process for identification and analysis of information support requirement. For organisations developing complex technical systems, their sub-contractors and service providers, there are critical macro-level information support requirements related to the continuous

improvement of the system-of-interest and associated enabling systems. One important aspect of Operational Monitoring (OM), Lifecycle Management (LCM) and continuous improvement, is their interdependencies with requirements on information support for the execution of performance-based contracts and functional sales, e.g. business models such as Performance Based Logistic (PBL) and power-by-the-hour. On a micro-level some of the critical requirements are: a reduced number of interfaces to information sources, improved fault diagnosis, knowledge sharing and automated procedures for technical administration.

The presented research imply that processes governing the development and modification of a complex system-of-system would benefit substantial from an integration of presented model-based approach for Integrated Logistic Support in general, and information support concepts and solutions in particular. Efforts that should be prioritized are the coordination and standardisation of project use of system modelling languages such as SysML and Es-UP, as well as shared product data and information, to facilitate integration of ICT-components and subsystems between system-of-interest and enabling system.

## **9.2 Conclusions Related to RQ 2**

The second research question of this research was stated as: what characterise suitable Information & Communication Technology (ICT) methodologies and technologies for the fulfilment of information support requirements of customers and providers?

The objective of RQ 2 is to identify Information & Communication Technology (ICT) related tools and methodologies suitable to fulfil the information support requirements of customers and support providers.

Since one of the main purposes of information support is to facilitate the maintenance process, the constitution of an information support solution need to be considered from a service-oriented perspective, in order to increase its adaptability to the different parts of the maintenance and support processes in different organisations. Hence, information support can be considered as a solution for smart content sharing between information provider and information consumer.

It can be concluded that provision of solutions for information support are highly dependent on data and information produced within various processes, e.g. operation and maintenance processes. In this interdependent and complex information context, it is important to identify characteristics that

are related to ICT-based methodologies and technologies in order to develop appropriate ICT-based solutions for information support.

In this research a set of important characteristics related to ICT-tools has been identified, see Section '7.3 Result III Related to RQ2'. These identified characteristics can be used to select proper methodologies and technologies when developing information support solutions.

### **9.3 Conclusions Related to RQ 3**

The third research question of this research was stated as: how can Information & Communication Technology (ICT)-based information support solutions that satisfy the information support requirements of customers and providers be developed?

The objective of RQ 3 is to provide artefacts that can be used in development of ICT-based information support solutions..

In this research, a development process has been suggested. The process has been partly verified, and can be utilised as a handrail during development of ICT-based solutions for information support. The suggested process consists of five iterative (5) phases: identification, design, development, implementation and deployment of ICT-based solutions for information support, see Section 'Results IV Related to RQ3'. The suggested process and its inherent phases are developed based on system-oriented, services-oriented, process-oriented and lifecycle-oriented approach to fulfil identified requirements on methodologies and technologies.

Furthermore, in this research a number of tools which can be used during the suggested process' inherent phases have been identified, see Section 7.4 Result IV Related to RQ3. Some of the identified tools have been used during the concept development, see Chapter 6 Description of Concept Development.

It can be concluded that in order to develop information support solutions effectively and efficiently there is a need of harmonised and aligned methodologies and technologies based on a system-oriented, service-oriented, process-oriented and lifecycle-oriented approach. Hence, this research suggests a model that can be used to develop of information support solution based on this approach and with use of existing tools.

## **9.4 Research Contribution**

The development of information support solutions is highly dependant on improved utilisation of ICT and eMaintenance for the provisioning of enhanced, process oriented information services for support to complex technical systems. This development of information support solutions can be facilitated through the use of a structured process containing methodology, formalised yet adaptable development processes and tools.

The presented research study contributes with the following:

- A definition of system-oriented, service-oriented, process-oriented and lifecycle-oriented information support solutions is provided.
- A set of identified critical information and information support requirements of customers and providers is identified, summarised and presented.
- A set of identified and categorised characteristics of ICT suitable to fulfil the information support requirements of customers and providers is identified, summarised and provided.
- A process for development of ICT-based information support solutions that satisfy the requirements of providers is suggested.



## **10 Further Research**

During the progress of this research, several interesting research scopes have emerged. However, it has not been possible to pursue all of these within the research presented in this thesis. Hence, in this section some of these scopes are presented as suggestions for further research.

A topic of both academic and industrial interest that emerged clearly at the end of the eMaintenance 24/7 research project, was the question of infrastructure for data and information exchange between operators and suppliers. There is a real need to identify, adapt and integrate ICT-based methods and solutions for what is referred to as a eMaintenance-infrastructure. This infrastructure is needed to exchange data at a rate that enhance Operational Monitoring, Life Cycle Management and other qualified information support services. Services that are necessary to streamline operation and maintenance, and to support improved efficiency and further development of Performance Based Logistics and dynamic maintenance schedules. This research is granted financing within the fifth NFFP-programme (2009-2013), and will be performed in the same joint academic and industry constellation as the eMaintenance project presented in this thesis.

Another topic for further research that has emerged is the need to develop prognostic methodology that is coordinated with information support concepts. Thereby enabling efficient maintenance planning, Operational Monitoring (OM) and thus contribute to decreased Life Support Cost for complex components (e.g. expensive aircraft Line Replaceable Units, LRUs) by enabling Condition Based Maintenance (CBM) and efficient Life Cycle Management (LCM).

OM and LCM are becoming increasingly important as control instruments to manage the technical and commercial risks inherent in changing maintenance solutions (e.g. dynamic maintenance plans) and new business models. At the same time, the quality of data, existing ICT, tools, manual intervention and outdated information, security and privacy solutions are often a limitation for the development of OM, LCM and other qualified support services. These services are necessary to enable the streamlining of operation and maintenance as well as to support Performance Based Logistics (PBL) and contracted logistic support. This is a broad multi-disciplinary area of relevant future research.

The phenomenon of No Fault-Found (NFF) can be described as an inability in the maintenance process to reproduce a fault situation in different contexts, e.g. a fault situation in the aircraft cannot be reproduced during the test.

However, NFF is one the major cost drivers in the context of complex technical system, which need to be reduced. Hence, in order to approach issue one scope for further research could to provide transparent service-oriented eMaintenance services that can be utilised in different context, e.g. on-aircraft and off-aircraft. Transparent services increase the ability of the system to reproduce same type of data interpretation regardless of the current context and situation, since they invoke same type of data processing mechanism.

Model-based simulation within Integrated Logistic Support (ILS) development as part of a model based system engineering (SE) process is another research area or great interest, not least from an industry perspective. Access to efficient methodologies and tools that support an experimental and evolutionary approach for feasibility studies, concept development, service design and service optimization (e.g. thru the combination of simulation and Design of Experiment, DoE), may have significant impact on both service development processes and business development processes. The latter as simulation models, besides being a powerful engineering development tool, have the potential to function as a pedagogical tool used for both the initial provider-customer dialog, and a formal representation used for contracting and evaluation of services as well as more complex Performance Based Logistic solutions.

It is also notable that the current development trend regarding the characteristics of the technical system itself, i.e. the system-of-interest, is towards more and more built-in maintenance related functions and capabilities. It becomes more and more common to build in capabilities such as on-board prognostics in vehicles, equipment and sub-systems that. These items can also be designed to contain their own product and configuration data, as well as store their own maintenance and support data and information. This raises the need for research to achieve even better integration of development processes for system-of-interest and enabling systems, as well as maintenance processes and support solutions. If such integration is successful, it may eventually make the distinction between system-of-interest and enabling system meaningless or even irrelevant from a technological point of view.

## References

- Ahlgren, J., Christofferson, L., Jansson, L. and Linnér, A. (1998). *Faktaboken om Gripen*. (4th ed.), Industrigruppen JAS. (In Swedish.)
- Ahmadi, A. (2007). *An assessment of operational consequences of failures to support aircraft scheduled maintenance program development*. Licentiate Thesis, Luleå University of Technology, Luleå, Sweden.
- Akao, Y. (ed.) (1992). *Quality function deployment - integrating customer requirements into product design*. Cambridge, Mass.: Productivity Press.
- Alvesson, M. and Sköldböck, K. (1994). *Tolkning och reflektion: Vetenskapsfilosofi och kvalitativ metod [Interpretation and reflection: Scientific philosophy and qualitative methodology]*. Studentlitteratur AB, Lund, Sweden. (In Swedish)
- ASD (2008). *S1000D - International specification for technical publications: utilizing a common source database*. Aerospace and Defence Industries Association of Europe - ASD and Ministries of Defence of the member countries of ASD, no. 4.
- ASD (2009). The AeroSpace and Defence Industries Association of Europe, ASD, available at: < <http://www.asd-europe.org> >, accessed: 2 October 2009.
- Bangemann, T., Rebeuf, X., Reboul, D., Schulze, A., Szymanski, J., Thomesse, J-P, Thron, M. and Zerhouni, N. (2006). PROTEUS - Creating distributed maintenance systems through an integration platform. *Journal of Computers in Industry*, vol. 57, no. 6, pp. 539-551.
- Bangemann, T., Reboul, D., Szymanski, J., Thomesse, J-P and Zerhouni, N. (2004). PROTEUS - An Integration Platform for Distributed Maintenance Systems. Proceedings of the *Intelligent Maintenance Systems (IMS) 2004 International Conference*, 15-17 July 2004, Arles, France.
- Barnett, W. D. and Raja, M. K. (1995). Application of QFD to the software development process. *International Journal of Quality & Reliability Management*, vol. 12, no. 6, pp 24-42.
- Bergman, B. and Klefsjö, B. (2003). *Quality from Customer Needs to Customer Satisfaction*. Studentlitteratur, Lund, Sweden.
- Berleur, J., Beardon, C. and Laufer, R. (1993). Facing the challenge of risk and vulnerability in an information society. Proceedings of the *IFIP WG9.2*

- Working Conference on Facing the Challenge of Risk and Vulnerability in an Information Society, 1993, Namur, Belgium.*
- Biedenbender, R., Vryn, F. and Eisaman, J. (1993). *The ILS Manager's LSA Toolkit: Availability Engineering*. McGraw-Hill Professional.
- Bijker, W. E., Hughes, T. H. and Pinch, T. J. E. (1987). *The Social construction of technological systems*. New directions in the sociology and history of technology. London: MIT Press.
- Bischoff, Hans-Jürgen. (2008) *Risks in modern society*. Volume 13 of Topics in safety, reliability, and quality. IFIP transactions. *Computer science and technology*, vol. 33, p 17. Springer.
- Blanchard, B. S. (2004). *Logistics Engineering and Management*. Fourth edition, Prentice-Hall, Englewood Cliffs, New Jersey.
- Blanchard, B.S. (2001). Systems, Systems Engineering, Logistics and Product Support. *SOLEtech: Newsletter Published by SOLE – The International Society of Logistics*, vol. 4, no. 10, pp. 1-15.
- Blanchard, B.S. and Fabrycky, W.J. (1998). *Systems Engineering and Analysis*. Third edition, Prentice-Hall, Upper Saddle River, New Jersey.
- Block, J. (2009). *Dependability analysis of military aircraft fleet performance in a lifecycle perspective*. Licentiate Thesis, Luleå University of Technology, Luleå, Sweden.
- Bryman, A. (2001). *Social Research Methods*. Oxford: Oxford University Press.
- Campbell, J.D. and Jardine, A.K.S. (2001). *Maintenance Excellence: Optimizing Equipment Life-Cycle Decisions*. Marcel Dekker, New York, USA.
- Canaday, Henry. (2004). Hunting for Productivity Gains, *Aviation Maintenance*, September 10, 2004, available at:  
<[http://www.aviationweek.com/aw/generic/story\\_generic.jsp?channel=om&id=news/om904cvr.xml](http://www.aviationweek.com/aw/generic/story_generic.jsp?channel=om&id=news/om904cvr.xml)>, accessed: 2 October 2009.
- Candell, O. (2004). *Development of User Information Products for Complex Technical Systems*. Licentiate thesis, Luleå University of Technology, Luleå, Sweden.
- Candell, O. and Söderholm, P. (2006). A customer and product support perspective of eMaintenance. Proceedings of the 19<sup>th</sup> International Congress of COMADEM, Luleå, Sweden, pp. 243-252.

- Careless, J. (2004). Airbus's New Support Strategy Values Customer Service. *Aviation Maintenance*, April 1, 2004, available at: <<http://www.aviationtoday.com/am/categories/maintenance/170.html>>, accessed: 27 September 2009.
- Carson, R. S. (1998). Requirements Completeness: A deterministic Approach. In *Proceedings of 8th Annual International INCOSE Symposium*, July 1998, Vancouver, BC, Canada.
- Chan, L. and Wu, M. (2002). Quality Function deployment: A literature review. *European Journal of Operational Research*, vol. 143, no. 3, pp. 463-497.
- Checkland, P. (2007). *Systems Thinking, System Practices*. John Wiley & Sons Ltd, England.
- Coetzee, J. (1998). *Maintenance*. Maintenance Publishers, Hatfield.
- Dahmström, K. (1996). *Från datainsamling till rapport: att göra en statistisk undersökning*. Lund: Studentlitteratur. (In Swedish).
- Deming, W. E. (1994). *The New Economics - for industry, government, education*. Cambridge, Massachusetts: MIT Press.
- DoD, US (1986). *Integrated Logistics Support Guide*. Department of Defense, Defense Systems Management College, Fort Belvoir, Virginia.
- Drury, C. G., Patel, S. C. and Prabhu, P. V. (2000). Relative advantage of portable computer-based workcards for aircraft inspection. *Industrial Ergonomics*, vol. 26, iss. 2, pp. 163-176.
- Fabrycky, W. J. and Blanchard, B. S. (1991). *Life-Cycle Cost and Economic Analysis*. New Jersey: Prentice-Hall.
- FMV (2006). *Provision of a/c "PBTH" & Transfer of SAAB 105 a/c*. Swedish Defence Materiel Administration (Försvarets Materielverk, FMV), Doc. Ref. 295155 - AI697524, 2006-09-08, Sweden.
- Goffin, K. (2000). Design for Supportability: Essential Components of New Product Development. *Research Technology Management*, vol. 43, no. 2, pp. 40-47.
- Graber, M. (2004). The Safety of Computer-Based Medication Systems/In reply. *Archives of Internal Medicine*, vol. 164, no. 3, pp. 339.
- Griffiths, D. (2000). AFM evaluates the Gripen. *Air Forces Monthly*. No. 144.

- Grönroos, Christian (2007). *Service Management and Marketing 3<sup>rd</sup> Edition*. John Wiley & Sons.
- Gummesson, E. (2000). *Qualitative Methods in Management Research*. (2nd ed.), Thousand Oaks: Sage.
- Hamel, W.R. (2000). e-Maintenance Robotics in Hazardous Environments. In: *Proceedings of the 2000 IEEE/RSJ International Conference on Intelligent Robots and Systems*. In: *Proceedings of: Second international conference on management of healthcare and medical Technology*. Chicago, Illinois, USA, 28th -30th July 2002.
- Henderson, R.M. and Clark, K.B. (1990). Architectural innovation: The reconfiguration of existing product technologies and the failure of established firms, *Admin Sci Quart*, vol. 35, no. 1, pp. 9-30 [Special Issue: *Technology, Organizations, and Innovation*].
- Herzwurm, G. and Schockert, S. (2003). The leading edge in QFD for software and electronic business. *International Journal of Quality & Reliability Management*, vol. 20, no. 1, pp. 36-55.
- Hewson, R. (1995). Saab JAS39 Gripen. *World Air Power Journal*, vol. 20, pp. 30-51.
- Hoc, J.-M., Cacciabue, P. C. and Hollnagel, E. E. (eds.) (1995). *Expertise and technology: Cognition and human-computer cooperation*. Hillsdale, N. J: Lawrence Erlbaum Associates.
- Holmberg, C. (1987). *Om forskning, in Grundbok i forskningsmetodik*. eds. R. Patel and U. Tibelius, Lund: Studentlitteratur. (In Swedsh).
- Hutchins, E. (1995). *Cognition in the wild*. Cambridge, Mass. MIT Press.
- IEC (2001). 60300 (3-12): *Dependability management - Part 3-12: Application guide -Integrated Logistic Support*. International Electrotechnical Commission, Geneva, Switzerland.
- IEC (2004). 60300 (3-14): *Dependability management - Part 3-14: Application guide - Maintenance and maintenance support*. International Electrotechnical Commission, Geneva, Switzerland.
- IEC (2008). 60300 (3-16): *Dependability management - Part 3-16: Application guide - Guideline for the specification of maintenance support services (Final Draft)*. International Electrotechnical Commission, Geneva, Switzerland.

- IEV (2008). *International Electrotechnical Vocabulary (IEV)*. Available at: <<http://www.electropedia.org/>>, accessed: 18 August 2008.
- Ingelstam, L. (ed.) (1996). *Complex Technical Systems*. Stockholm: Council for Planning and Coordination of Research (FRN).
- ISO (1998). *Ergonomic requirements for office work with visual display terminals (VDTs) -- Part 11: Guidance on usability*. International Organization for Standardization (ISO).
- ISO/IEC (2008). *15288: Systems engineering - System life cycle processes*. International Organization for Standardization and International Electrotechnical Commission, Geneva, Switzerland.
- IST (2008). *Dynamic Decisions in Maintenance (DYNAMITE)*. *Information Society Technology (IST)*, available at: <<http://www.ist-world.org/ProjectDetails.aspx?ProjectId=2ae617135ecd4cb7bcefcfa8f05577c5>>, accessed: 14 October 2008.
- Iung, B. and Crespo, M. A. A. (2006). Editorial: Special Issue on eMaintenance. *Journal of Computers in Industry*, vol. 57, no. 6, pp. 473–606.
- Jacobson, R. (ed.) (2000). *Information Design*. Cambridge, Massachusetts: MIT Press.
- Jernbäcker, M. (2003). *Användningsfall - flygplanstekniker*. Sörman Information & Media. (In Swedish).
- Jayaratna, N. (1994). *Understanding and Evaluation Methodologies NIMSAD: A Systematic Framework*. McGraw-Hill, Berkshire, England.
- Jensen, David. (2008) Special Report: TATEM: Europe's Future View of Maintenance *Aviation Today*. October 1, 2007, available at <<http://www.aviationtoday.com/am/categories/commercial/16093.html>>, accessed: 27 September 2008.
- Kans, M. (2008). *On the utilisation of information technology for the management of profitable maintenance*. Doctoral thesis, Växjö University, Växjö, Sweden.
- Kar, P. and Baily, M. (1996). Characteristics of Good Requirements. In *Proceedings of 6th Annual International INCOSE Symposium*, July 1996.
- Karim, R. (2008). *A Service-Oriented Approach to eMaintenance of Complex Technical Systems*, Doctoral Thesis, Luleå University of Technology, Luleå, Sweden.

- Karim, R., Kajko-Mattsson, M. and Söderholm, P. (2008a). Exploiting SOA within eMaintenance. Proceedings of the 30<sup>th</sup> International Conference on Software Engineering (ICSE), the 2<sup>nd</sup> international workshop on Systems development in SOA environments, 10 May 2008, Leipzig, Germany.
- Karim, R., Kajko-Mattsson, M., Söderholm, P., Candell, O., Tyrberg, T., Öhlund, H. and Johansson, J. (2008b). Positioning Embedded Software Maintenance within Industrial Maintenance. Proceedings of the 24<sup>th</sup> IEEE International Conference on Software Maintenance (ICSM), 28 September 2008, Beijing, China.
- Karim, R., Candell, O. and Söderholm, P. (2008c). Development of ICT-based Maintenance Support Services. *Journal of Quality in Maintenance Engineering*, vol. 15, iss. 2, pp. 127-150.
- Karlsson, J. (1998). *A Systematic Approach for Prioritizing Software Requirements*. PhD.thesis, Linköping University, Department of Computer and Information Science.
- Karlsson, J. (1995). *Towards a Strategy for Software Requirements Selection*. Lic.thesis, Linköping University, Department of Computer and Information Science.
- Kim, S.H., Cohen, M.A., and Netessine, S. (2007). *Performance Contracting in After-sales Service Supply Chains*. In Reliability and Maintainability Symposium, 2007. Management Science, volume 53 of 12, pages 1843-1858.
- Klefsjö, B., Eliasson, H. and Kennerfalk, L. (1999). *De sju ledningsverktygen : för effektivare planering av förbättringsarbetet*. Lund: Studentlitteratur. (In Swedish)
- Koc, M. and Lee, J. (2001). A system framework for next-generation E-Maintenance Systems. Proceedings of the 2<sup>nd</sup> international symposium on environmentally conscious design and inverse manufacturing, 11-15 December 2001, Tokyo, Japan.
- Kontonya, G. and Sommerville, I. (1998). *Requirements Engineering: Processes and Techniques*. John Woley, Chichester.
- Kotler, P. (1997). *Marketing Management*. (9th ed.), Upper Saddle River, New Jersey: Prentice-Hall.
- Kumar, R. (2003). *Study and Analysis of Service Delivery Strategy for Industrial Systems*. Licentiate thesis, Luleå University of Technology, Department



of Civil and Mining Engineering, Division of Operation and Maintenance Engineering.

- Lee, J., Ni, J., Djurdjanovic, D., Qiu, H. and Liao, H. (2006). Intelligent prognostics tools and e-maintenance. *Journal of Computers in Industry*, vol. 57, no. 6, pp. 476-489.
- Levrat, E., Iunga, B. and Crespo Marquez, A. (2008). E-maintenance: review and conceptual framework. *Production Planning & Control*, vol. 19, no. 4, June 2008, pp. 408-429.
- Liyanage, J.P. and Kumar, U. (2003). Towards a value-based view on operations and maintenance performance management. *Journal of Quality in Maintenance Engineering*, vol. 9, no. 4, pp. 333-350.
- Lorell, M., Raymer, D. P., Kennedy, M. and Levieux, H. (1995). *Grey threat : assessing the next-generation European fighters*. Santa Monica, Ca.: Rand Corporation.
- Markeset, T. (2003). *Dimensioning of Product Support: Issues, Challenges and Opportunities*. Doctoral Thesis, Hogskolan i Stavanger, Stavanger, Norway.
- Markeset, T. and Kumar, U. (2003). Design and development of Product Support and Maintenance Concepts for Industrial Systems. *Journal of Quality in Maintenance Engineering*, vol. 9, no. 4, pp. 376-392.
- McDonnell, M. and Clegg, B. (2007). Designing a Support System for aerospace maintenance supply chains. *Journal of Manufacturing Technology Management*, vol. 18, no. 2, pp. 139-152.
- Miles, M.B. and Huberman, A.M. (1994). *An Expanded Sourcebook: Qualitative Data Analysis*. Second Edition, Sage Publications, Thousand Oaks, California, USA.
- MIMOSA (2008). Machinery Information Management Open System Alliance. MIMOSA, available at <<http://www.mimosa.org/>>, accessed: 20 MAY 2009.
- Mizuno, S. (1988). *Management for Quality Improvement: The Seven New QC Tools*. Productivity Press, Cambridge.
- Mokashi, A.J., Wang, J., Verma, A.K. (2002a) A study of reliability centred maintenance in ship operations, *International Journal of Marine Policy*, vol. 26, no.5, pp 325-335.

- Mokashi, A.J., Dastur, H., and Verma, A.K. (2002b). Shipboard Maintenance: Possible Future Trends, *Safety Science Monitor (International Journal)*, vol. 6, iss. 1, pp 22-25.
- Muller, A., Marquez, A. C. and Iung, B. (2008). On the concept of eMaintenance: Review and current research. *Journal of Reliability Engineering and System Safety*, vol. 93, no. 8, pp. 1165-1187.
- Murthy, D. N. P., Atrens, A. and Eccleston, J.A. (2002). Strategic maintenance management. *Journal of Quality in Maintenance Engineering*, vol. 8, no. 4, pp. 287-305.
- North, D. M. (1999). Gripen Key to Sweden's Air Defense Force. *Aviation Week & Space Technology*, (151), 68-72.
- O'Connor, P. D. T. (1991). *Practical reliability engineering*. (3rd ed.), Chichester: John Wiley & Sons.
- Parida, A. and Kumar, U. (2004). Managing Information is key to Maintenance Effectiveness. Proceedings of the *Intelligent Maintenance Systems (IMS) 2004 International Conference*, 15-17 July 2004, Arles, France.
- Parida, A., Phanse, K. and Kumar, U. (2004). An integrated approach to design and development of e-maintenance system. Proceedings of *VE-TOMAC-3 and ACSIM-2004*, New-Delhi, 6-9 December 2004, pp. 1141-1147.
- Patel, R. and Davidson, B. (2003). *Forskningsmetodikens grunder, Att planera, genomföra och rapportera en undersökning [Principles of Research Methodology: Plan, Conduct and Report a Research]*. Third edition, Studentlitteratur AB, Lund, Sweden. (In Swedish)
- Patel, R. and Tibelius, U. (1987). Om osäkerhet vid insamlandet av information, in *Grundbok i forskningsmetodik*. eds. R. Patel and U. Tibelius, Lund: Studentlitteratur.
- Rational (2008). Rational Software. IBM, available at: <<http://www-01.ibm.com/software/rational/>>, accessed: 27 August 2008.
- Rolls-Royce (2009). *TotalCare - Rolls-Royce*, available at: <http://www.rolls-royce.com/civil/services/totalcare/>, accessed: 27 October 2008.
- Saab (2005). *NFFP4-S4401: Projektspecifikation e-underhåll 24-7 (TS-2005-0124) [Project specification eMaintenance]*. Saab Aerosystems. Linköping, Sweden. (In Swedish)

- Saab (2007a). *Product Concept and Business Plan for Maintenance Works Station – MWS*. FAT-2007-0040 FH. Saab Aerotech, Linköping, Sweden.
- Saab (2007b). *PM Possible applications for an e-Maintenance concept (FAT-2007-0052)*. Saab Technologies. Linköping, Sweden.
- Saab (2007c). *Maintenance Workstation (FAT-2007-0040)*. Saab Technologies. Linköping, Sweden.
- Saab (2008). *Gripen Support System Description*. Saab Technologies, Linköping, Sweden. June 2008.
- Saab (2009a). *Process F040 - Develop Maintenance System*. Linköping, Sweden. September 2009.
- Saab (2009b). *Maintenance System Gripen NG. Sub-System Concept/Specification, Information Management System*. Reg. No. FADI-2009-0011. 2009-09-15. Linköping, Sweden.
- Saab (2009c). *Gripen NG Information Management Use-Cases, input/output requirements and dependencies*. Reg. No. FAD-2009-0039. 2009-01-15. Linköping, Sweden.
- Sandberg, A. and Strömberg, U. (1999). Gripen: with focus on availability performance and life support cost over the product life cycle. *Journal of Quality in Maintenance Engineering*, vol. 5, no. 4, pp. 325-334.
- Schütte, S. (2002). *Designing feelings into products - Integrating Kansei Engineering Methodology in Product Development*. Lic.thesis, Linköping University, Quality and Human-Systems Engineering, Department of Mechanical Engineering.
- Seidenman, P. and Spanovich, D. (2009). Airlines Spending Money on IT. *Aviation Week*, McGraw-Hill. available at: [http://www.aviationweek.com/aw/generic/story\\_generic.jsp?channel=om&id=news/om1204cvr.xml](http://www.aviationweek.com/aw/generic/story_generic.jsp?channel=om&id=news/om1204cvr.xml), accessed: 01 Oktober 2009.
- Smith, D. (2008). HUMS Ascension. *Aviation Maintenance*, 1 February 2008. available at: [http://www.aviationtoday.com/am/categories/rotocraft/HUMS-Ascension\\_18851.html](http://www.aviationtoday.com/am/categories/rotocraft/HUMS-Ascension_18851.html), accessed: 1 October 2009.
- Sonesson, K. (2000). *Technical Communication through Digital Media*. M.Sc.thesis, Växjö University, Media och Kommunikationsvetenskap.

- Söderholm, P. (2005). *Maintenance and Continuous Improvement of Complex Systems: Linking stakeholder Requirements to the Use of Built-in Test Systems*. Doctoral Thesis, Luleå University of Technology, Luleå, Sweden.
- Söderholm, P. (2007). A system view of the No Fault Found (NFF) phenomenon. *Reliability Engineering & System Safety*, vol. 92, no. 1, pp. 1-14.
- Söderholm, P., Holmgren, M. and Klefsjö, B. (2007). A process view of maintenance and its stakeholders. *Journal of Quality in Maintenance Engineering*, vol. 13, no. 1, pp. 19-32.
- Söderholm, P., Karim, R. and Candell, O. (2008). Identifying information-based maintenance support services through the design of simulations. (submitted to a journal).
- Sommerville, I. (2006). *Software Engineering*. Addison-Wesley.
- Suh E.S., Furst M.R., Mihalyov K.J, de Weck O. (2009). Technology Infusion for Complex Systems: A Framework and Case Study, SE-080701, *Systems Engineering*, vol. 12, no. 4.
- Tsang, A. (2002). Strategic dimension of maintenance management. *Journal of Quality in Maintenance Engineering*, vol. 8, no. 1, pp. 07-39.
- UK Ministry of Defence (MOD). (2008). *Integrated Logistic Support Policy, information and guidance on the Integrated Logistic Support aspects of UK MOD Defence Acquisition*. Version 1 - May 2008, available at: <[http://www.aof.mod.uk/aofcontent/tactical/ILS/content/ils\\_influenecedesign.htm](http://www.aof.mod.uk/aofcontent/tactical/ILS/content/ils_influenecedesign.htm)>, accessed: 8 October, 2009.
- US Department of Defence (US DD). (1997). *Department of Defense Handbook Acquisition Logistics*. MIL-HDBK-502, 30 May 1997, available at: <<https://www.logsa.army.mil/lec/downloads/standards/milhdbk502.pdf>>. MIL-HDBK-502, Notice 1, 20 January 2005. Notice of validation, available at: [http://www.responseboatproject.net/sections/Section\\_J/References/MIL-HDBK-502.pdf](http://www.responseboatproject.net/sections/Section_J/References/MIL-HDBK-502.pdf)>, accessed: 7 October, 2009.
- Wachs, M. (2002). Fighting traffic congestion with information technology. *Issues in Science and Technology*, vol. 19, no. 1, pp. 43-51.
- Williams, T., Maull, R., Ellis, B. (2002). Demand chain management theory: constraints and development from global aerospace supply webs, *Journal of Operations Management*, vol. 20, iss. 6, pp.691-706.

- Winner, L. (1977). *Autonomous Technology: Technincs-out-of-control as a Theme in Political Thought*. Cambridge, MA.: MIT Press.
- Webster-on-line Dictionary (2009), available at: < <http://www.merriam-webster.com/>>, accessed: Mars through October 2009.
- Yin, R.K. (2003). *Case Study Research – Design and Methods*. Third edition, Sage Publications, Thousands Oaks, California, USA.
- Yin, R.K. (2003). *Case Study Research – Design and Methods*. Third edition, Sage Publications, Thousands Oaks, California, USA.
- Zultner, R. E. (1993). TQM for technical teams. *Communications of the ACM*, vol. 36, no. 10, pp. 79-91.
- Yua, R., Iunga, B., Panetto, H. (2003) A multi-agents based E-maintenance system with case-based reasoning decision support. *Engineering Applications of Artificial Intelligence*, vol. 16, no. 4, pp. 321-333.
- Yoshizawa, T., Togari, H. and Kuribayashi, T. (1992). *Quality Function Deployment for Software Development*, in *Quality function deployment: integrating customer requirements into product design*. ed. Y. Akao, Cambridge, Mass: Productivity Press.



## Appended Papers

### Paper I

Candell, O., Karim, R. and Söderholm, P. (2009). eMaintenance: Information logistics for maintenance support. *Journal of Robotics and Computer-Integrated Manufacturing*, vol. 25, issue 6. **(Published)**

### Paper II

Karim, R., Candell, O., and Söderholm, P. (2009). Development of ICT-based Maintenance Support Services. *Journal of Quality in Maintenance Engineering*, vol. 15, issue 2. **(Published)**

### Paper III

Karim, R., Candell, O., and Söderholm, P. (2009). E-maintenance and Information Logistics: Aspects of Content Format. *Journal of Quality in Maintenance Engineering*, vol. 15, issue 3. **(Published)**

### Paper IV

Söderholm, P., Karim, R. and Candell, O. (2008). *Design of Experiments and Simulation for Identification of Significant eMaintenance Services* **(Submitted to a journal)**

### Paper V

Candell, O., Karim, R., Söderholm, P. and Kumar, U. (2009). Service-oriented information logistics as support to intelligent transport services. The 16<sup>th</sup> World Congress and Exhibition on Intelligent Transport Systems and Services, 21st-25th September 2009, Stockholm, Sweden. **(Published)**

### Paper VI

Candell, O. and Karim, R. (2008). eMaintenance - Information Driven Maintenance and Support. Proceedings of the 18<sup>th</sup> International Conference on Flexible Automation and Intelligent Manufacturing (FAIM 2008), 30<sup>th</sup> June - 2<sup>nd</sup> July 2008, Skövde, Sweden. **(Published)**





# PAPER I

## **eMaintenance: Information logistics for maintenance support**

**Candell, O.,** Karim, R. and Söderholm, P. (2009). eMaintenance: Information logistics for maintenance support *Journal of Robotics and Computer-Integrated Manufacturing*, vol. 15, issue 1.



Provided for non-commercial research and education use.  
Not for reproduction, distribution or commercial use.



This article appeared in a journal published by Elsevier. The attached copy is furnished to the author for internal non-commercial research and education use, including for instruction at the authors institution and sharing with colleagues.

Other uses, including reproduction and distribution, or selling or licensing copies, or posting to personal, institutional or third party websites are prohibited.

In most cases authors are permitted to post their version of the article (e.g. in Word or Tex form) to their personal website or institutional repository. Authors requiring further information regarding Elsevier's archiving and manuscript policies are encouraged to visit:

<http://www.elsevier.com/copyright>





Contents lists available at ScienceDirect

# Robotics and Computer-Integrated Manufacturing

journal homepage: [www.elsevier.com/locate/rcim](http://www.elsevier.com/locate/rcim)

## eMaintenance—Information logistics for maintenance support

Olov Candell<sup>a,1</sup>, Ramin Karim<sup>b,\*</sup>, Peter Söderholm<sup>c,2</sup><sup>a</sup> Saab Aerotech, Aircraft Services Division, SE-581 88 Linköping, Sweden<sup>b</sup> Division of Operation and Maintenance Engineering, Luleå University of Technology, SE-971 87 Luleå, Sweden<sup>c</sup> Division of Quality Technology, Environmental Management and Social Informatics, Luleå University of Technology, SE-971 87 Luleå, Sweden

### ARTICLE INFO

#### Article history:

Received 1 December 2008

Received in revised form

24 February 2009

Accepted 9 April 2009

#### Keywords:

Maintenance

Support services

Information logistics

Aviation

Service-Oriented Architecture (SOA)

### ABSTRACT

Today's providers of maintenance and in-service support related to modern aircraft are facing major challenges. A central problem with Maintenance, Repair and Overhaul (MRO) as well as support of aircraft and other complex technical systems, is to manage the ever-increasing information flow and system complexity. Both military and commercial operators need to reduce aircraft downtime and maintenance man hours. Increased manual information management has the opposite effect, inducing unnecessary cost and affect efficiency negatively. Organizations developing and providing maintenance support products and in-service support does also need to improve the capability to efficiently exploit the increasing amount of digital product information and design data provided together with hardware (HW) and software (SW) products from aircraft manufacturers, sub-system suppliers and Original Equipment Manufacturers (OEM). One way to increase aircraft availability and improve maintenance and support efficiency, is to speed up the turnaround time for scheduled and unscheduled maintenance. The ultimate goal is risk-based utilization and support, where true Condition-Based Maintenance (CBM) is integrated with current operational requirements and available resources in real-time. This aims at the elimination of all preventive scheduled maintenance based on fixed time intervals and execution of only corrective maintenance that has been predicted and turned into scheduled maintenance facilitated by proper support. To address the challenge of information logistics of digital product data and information within maintenance in-service support, providers need to adapt new methodologies and tools that enable full utilization of the advantages of digital product data and information in processes and business models, e.g., Service-Oriented Architecture (SOA). To implement such improved support solutions in a global-support environment, eMaintenance is seen as one important building block. eMaintenance includes monitoring, collection, recording and distribution of real-time system health data, maintenance-generated data as well as other decision and performance-support information to different stakeholders independent of organization or geographical location, 24 h a day, 7 days a week (24/7). eMaintenance has the potential to improve the management and performance of activities related to the whole maintenance process, and thereby improve the dependability, safety and Life Cycle Cost (LCC) of critical systems. This can be realized through a coordinated application of Information and Communication Technology (ICT) throughout the maintenance and support processes, thus integrating Built-in Test (BIT) systems, external tests at different maintenance echelons, technical information, diagnostics, prognostics and other sources of support information.

The purpose of this paper is to present some results from a joint academic and aerospace industry research project, describing requirements and expectations that are important in a global-support environment, and also to propose some central components in an eMaintenance framework that integrates maintenance and ICT perspectives.

© 2009 Elsevier Ltd. All rights reserved.

### 1. Introduction

Aircraft manufacturers, as well as maintenance and in-service support providers, are experiencing ever-increasing customer requirements to increase dependability and decrease Life Support Cost (LSC). To achieve this, a central problem for the industry is to manage the rapidly increasing information flow that follows the development of more complex and technologically advanced

\* Corresponding author. Tel.: +46 920 49 23 44.

E-mail addresses: [olov.candell@saabgroup.com](mailto:olov.candell@saabgroup.com) (O. Candell), [ramin.karim@itu.se](mailto:ramin.karim@itu.se) (R. Karim), [peter.soderholm@itu.se](mailto:peter.soderholm@itu.se) (P. Söderholm).<sup>1</sup> Tel.: +46 13 18 17 39.<sup>2</sup> Tel.: +46 920 49 20 77.

aircraft systems [1]. Customers are also demanding improved system availability, safety, sustainability, cost-effectiveness, operational flexibility and tailored worldwide support 24 h a day, 7 days a week (24/7). This changing business environment requires new and innovative solutions as support products and services to satisfy the needs of customers and end-users.

Maintenance and support concepts for modern complex technical systems, such as civil airliners and military combat aircraft, can be described as focussing on optimizing two fundamental and interdependent elements. The first element is the aircraft (i.e., the system-of-interest), which should be designed to maximize the inherent availability through proper reliability and maintainability design within available Life Cycle Cost (LCC) constraints. This design should be balanced with the support system, which is the second element. The support system should be designed to provide necessary support during the utilization and support phases of the system-of-interest's life cycle, which is measured through the support system's maintenance support performance. The support system is an enabling system, i.e., a system that complements a system-of-interest during its life-cycle stages [2], but does not necessarily contribute directly to its function during operation [3]. An enabling system provides functions and services to users and other stakeholders to ensure a proper and efficient function of the system-of-interest [2].

On an operational level, end-users and managers utilizing the support system of a modern aircraft are confronted with a multitude of computerized functions and Information and Communication Technology (ICT) solutions. However, today there is little or no integration of functions and services related to the support system, such as technical information (publications), maintenance programmes, maintenance plans, job cards, fault diagnosis support, amendment services, health and usage monitoring and operational feedback [4,5].

At the same time, producers and suppliers of maintenance products and customer support services are facing escalating challenges trying to sustain high quality and increase service levels for increasingly complex technical systems in an environment characterized by multiple products, suppliers and customers with increasingly stringent requirements. This environment is also to a great extent becoming purely digital, i.e., an increasing amount of software (SW) and hardware (HW) products, design data and other information exchange is provided and communicated solely in digital form. Hence, both customers and suppliers are facing increased complexity levels regarding information related to configuration control and change management for both the aircraft and its support system. This high complexity level of information logistics will hamper the operational effectiveness and drive LCC.

Therefore, suppliers need to change methodologies, tools and processes for information logistics to be both more customer-focused and more efficient for internal development and sustainability. New concepts for the application of ICT need to address information quality, lead time, accessibility 24/7, usability and an overall reduction of cost for information logistics related to maintenance and support. Simultaneously, since much of the managed data and information related to military aircraft are sensitive and confidential the aspect of information security is of utmost importance and need to be considered, e.g. through content classification, authentication and authorization. In fact, information security is so fundamental that it can override the functionality of any solution.

Information logistics need to integrate and exploit the use of maintenance data and consider fleet status, flight operations and maintenance sources. This would provide, maintenance planners, operations and others with tailored information for decision support, derived from common data sources [6].

Examples of these trends are manufacturers' airline in flight information system. It can include multifunction e-applications for flight operations, passenger, cabin crew and maintenance features. Capabilities in flight operations include performance calculations, electronic manuals, technical logbook, crew e-mail, graphical weather, and charts and maps. For maintenance it includes technical logbook, manuals, maintenance tools and performance monitoring [7].

Capability also needs to be developed to enable more agile and efficient use of new maintenance and support functions integrated in the aircraft, exploitation of operational feedback, as well as rapid supplier adaptation to continuously changing customer specific requirements on HW and SW products as well as services.

An example of such solutions is again manufacturers' innovative support strategies, where customers pay for a significant portion of purchased services with data collected during operations. Maintenance, Repair and Overhaul (MRO) providers are also required to provide data such as man hours, downtime and reliability data. In return the manufacturer commit to include promotion of services from the MRO providers, information exchange in terms of access to specific information (draft service bulletins, information on market requirements, advance information on major retrofit programs) and management reviews [7].

## 2. Scope

This paper focuses on a concept for ICT-based products and services for maintenance of modern aircraft. However, it is believed to be extensively applicable to similar challenges regarding maintenance of other complex technical systems, e.g. within the transport, process and power industries, as well as telecom and health care. The paper presents requirements and needs regarding the mentioned products and services that are important for both suppliers and customers (operators) of modern aircraft systems in a global-support environment and proposes some central components of an information logistic concept for maintenance purposes, called eMaintenance Management Framework (eMMF), that integrates maintenance and ICT perspectives to address the challenges presented above.

The discussion of central characteristics of system-of-interest (e.g. aircraft) and enabling systems (e.g. a support system external to the aircraft) uses nomenclature based on established and agreed international standards. Availability is used as a general term referring to availability performance and its influencing factors: reliability performance (the way the aircraft is designed to eliminate the need of maintenance, i.e., reducing or eliminating the probability of loss of required functions); maintainability performance (the way the aircraft is designed to facilitate maintenance, i.e., to retain or restore the aircraft's required functions); as well as maintenance support performance (effectiveness and efficiency of the maintenance organization). See Ref. [8].

## 3. Maintenance within aviation

Experience from maintenance and support system development and real-life operations [9], combined with expectations for future scenarios, stress the importance of supporting the operational capability and competitiveness through high availability of aircraft. Increasing civil requirements on mobility and availability, and military operations from provisional bases combined with rapidly shifting conditions, increase the importance of information and decision support to personnel that maintain systems in operation. This high impact of integrated logistic support on

aircraft operations and the need to improve it regarding maintenance management, information system and logistic network is also observed in other research [10–13]. The aircraft and its support system's design need to be very structured and controlled, meeting requirements with the overall objective of maximizing the total system effectiveness at the lowest possible LCC, see Fig. 1.

The design of the support system also needs to take into account other requirements, such as operators' mixed aircraft fleet and requests to consider re-use of existing resources and capabilities (e.g. facilities, manpower, competencies, ICT and standards) and future requirements, operational or product development requirements, as well as desired levels of standardization and self-support [7].

New technology and innovation also drive development and create new needs. A military example is the so-called fourth generation combat aircraft, e.g. Dassault Rafale, Eurofighter Typhoon and Saab Gripen. These are system aircraft with a digital infrastructure and fully integrated computer systems that utilize a common database through standardized interfaces [15,16]. The building principle of a system-of-systems supplies an immense potential for functional development, but also an extremely complex aircraft system [9]. The civilian equivalents, such as the Boeing 787 Dreamliner and Airbus A350, have focused on ICT as a central component for more efficient maintenance and support solutions. A central part of this aircraft technology development is advanced Built-in Test (BIT) systems. The aircraft BIT is constantly being developed to improve safety, maintainability, testability and supportability of the aircraft as well as to provide health information. This extended access to qualified data from operation and maintenance provides the technical foundation for condition monitoring, extensive data recording, test, diagnostics, prognostics and decision support for condition-based utilization and support [9]. These technology trends, together with the pervasiveness of ICT in the maintenance system and support processes are also key-enabling factors for implementation of remote support services accessible worldwide and 24/7. Nevertheless, the BIT is itself a development that adds further requirements and puts strain on supporting ICT frameworks, information logistic processes and maintenance needs [17–19].

Thus, information logistics and new ICT-solutions have become a central aspect and common denominator for many of the new challenges regarding system complexity, configuration control, change management and applicability of product information, both for the systems-of-interest and their related support

systems. To meet the increasing demand on availability and to cut costs, maintenance and support actors are becoming increasingly dependent on ICT to provide timely and accurate information. Efficient ICT-solutions have rapidly risen as a key driver for good decision making and effective operations. One example of an area with great improvement potential is technical publications. A large proportion of the information support used by maintainers within aerospace is still paper documents, or 'paper-on-screen' solutions (e.g. paper publication suits published as PDF). This practice prevails despite the fact that new aircraft complexity, integrated digital systems and air-to-ground real-time communication technologies make document-oriented, paper-based approaches increasingly expensive to produce and offer inadequate usability. Hence, unnecessary costs are generated simply because maintainers often lack products and services for information support that are adapted to specific roles and situations, and therefore cannot work as efficiently as possible [4,20].

With reference to the problem and solution domains presented above, the concept of eMaintenance presented in this paper can be defined as a structured and coherent application of ICT throughout the whole life cycle of the support system, coordinated with technical solutions in the aircraft system. The main goal is to create a more effective and efficient maintenance process by optimization of an eMaintenance framework as a part of necessary maintenance support implemented in the enabling systems, and thereby improve overall system effectiveness.

To secure the performance of an aircraft at a reasonable cost, it is vital that the design of maintenance and product support concepts is done correctly right from the design phase [3,21]. The character, scope and allocation of the support needed, must also be influenced by the customers' competencies, as well as the operational environment, but also organizational and cultural issues [3,22]. The whole maintenance process needs to be taken into consideration, including its phases for management, support planning, preparation, execution, assessment and improvement (see Fig. 2). Hence, the requirements analysis must consider a multitude of aspects, facts, needs and properties of the technical system, customer requirements and the context of utilization and support for the given system, supplier requirements and other stakeholders, as well as environment and legislation.

Another aspect is that traditionally both civil and defence aerospace industries have built and sold systems to operators. Today, this approach is changing and the industry also has to provide services that traditionally have been carried out by the operators or other third-party suppliers. The highest degree of commitment is needed when delivering total care, or functional products, where the customers are offered availability performance at a fixed price. One example of this is the requirement of 'Maintenance Free Operating Period' (MFOP) on the military side

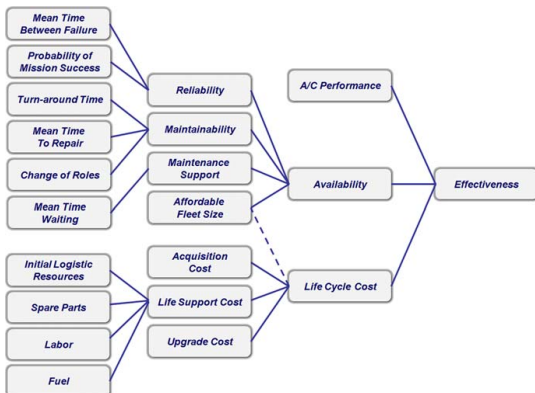

Fig. 1. Important requirements related to system effectiveness [14].

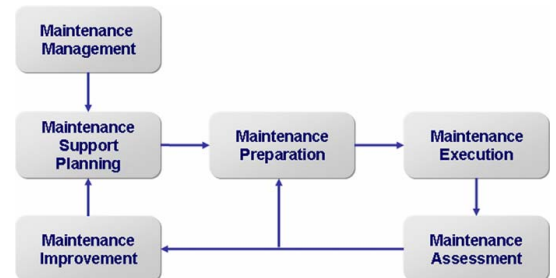

Fig. 2. Phases of an overall maintenance process, adapted from Saab (Internal document) [5].

and 'Power by the Hour' contracts on the civil side. These are market driven requirements on an eMaintenance solution, which introduce additional stakeholder perspectives [20].

**4. Maintenance requirements**

With reference to the material presented above, the development of products and services integrated with ICT in an eMaintenance solution for support to operation and maintenance of complex systems needs to address a number of central requirements such as

- integration of the system-of-interest and its enabling system to exploit technological development of modern aircraft and ICT in efficient solutions for global maintenance and support 24/7,
- facilitation of configuration control, change management and directive information applicability for both the system-of-interest and products and services included in the enabling system,
- integration of role- and situation-adapted products and services for information and performance support with high accessibility and usability,
- coordination and integration of consumption and production of information at different phases of the maintenance process,
- coordination and integration of tests, diagnostics and prognostics for condition-based utilization and support at different maintenance echelons,
- support to performance-based contracts and functional sales (e.g., power-by-the-hour),
- adherence to international (information) standards.

eMaintenance needs to facilitate support to operators and other stakeholders' work through information and performance support to the overall maintenance process related to modern

aircraft, including ground-support equipment and training devices. eMaintenance also needs to provide a framework and processes for managing product data and information, maintenance and support information, as well as feedback of data and information from operational and maintenance activities.

This spectrum of requirements that built on industrial and operator experience, drives the approach that the improvement of the operative performance and effectiveness of maintenance and support through the introduction of eMaintenance, need to target all phases of the maintenance process (see Fig. 2). In order for the aerospace industry to manage the risks associated with these new, diversified and enhanced solutions in a global-support environment, a wide collection of heterogeneous information sources need to be funnelled and made available for the right user, in the right format, in the right place, at the right time. In the past, the information flow has been quite rigid and inflexible between a rather small numbers of stakeholders. However, in the future the exchange of information is required to reflect closer working relationships and a more dynamic, global-support environment and deliver efficient and tailored support for decision making to stakeholders spanning from OEMs, sub-system suppliers, through system integrators onto operators, maintainers and support providers [20].

Another important requirement is that information logistic concepts within the aerospace industry need to be based on international standards for structured product data sharing. Central among these standards are Product Life Cycle Support (PLCS) [23], Sharable Content Object Reference Model (SCORM) [24] and the AeroSpace and Defence Industries Association of Europe (ASD) specifications suite of standards for Integrated Logistic Support (ILS); S1000D (technical publications), S2000M (material management), the emerging S3000L (Logistics Support Analysis, LSA) and S4000M (Reliability-Centred Maintenance, RCM).

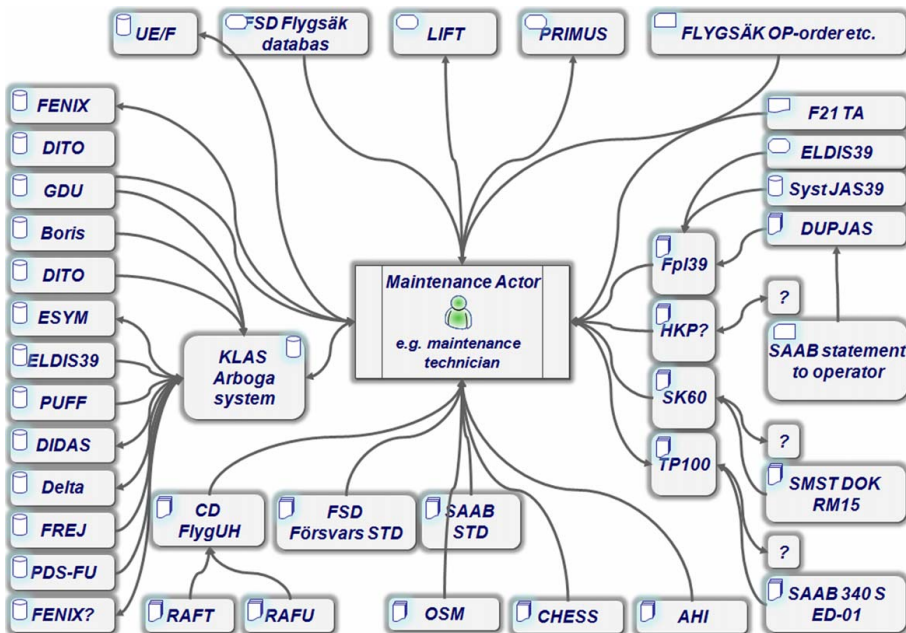

Fig. 3. Illustrating the example of information system needs of a Saab JAS 39 Gripen maintenance technician or planner.



As discussed above, the overall maintenance process involves phases for management, support planning, preparation, execution, assessment and improvement, see Fig. 2. These phases consist of different sets of activities, which are interrelated and adapted to fulfil requirements from different stakeholders. Stakeholders within the maintenance process consume and produce information when performing different activities. For example, during maintenance execution, a maintenance technician receives a work order that requires a maintenance action, and after the performed action the technician reports the outcome. The information from the execution process can further be aggregated to a context in the assessment process. As illustrated in Fig. 3, a maintenance actor, e.g. the maintenance technician, needs to interact with various types and formats of information through different information sources when conducting a maintenance action. This interaction can be reading, writing or both.

Hence, one of the main objectives of establishing an eMaintenance solution is to provide a supporting ICT-environment that improves the performance of the maintenance process by providing seamless and integrated services for sharing content. It is commonly accepted that data collection and distribution is a major issue in the maintenance process and a cornerstone in the area of eMaintenance [5]. It is also accepted that there is a need to be able to convert data to information, and based on this information to generate knowledge valuable for decision making. In order to make the right decisions, there is a need to be able to access and manage the right knowledge. Since knowledge, a term which basically refers to what is known, is not only a summarization of known raw data through information interpretation, but also implies other artefacts, such as documentation and experiences, the focus should be on the content and the content sharing as well as services in the maintenance process rather than on data and data processing [25]. Fig. 4 illustrates information flow between aircraft and some of the related

systems. This information is shared by supplier/provider and customer/operator.

ICT is one of the main prerequisites, not only to improve the effectiveness and efficiency of the maintenance process for complex systems with long life cycles, but also to reduce associated risks, and contribute to a more efficient business process. The utilization of ICT offers a more controlled content sharing, information exchange and knowledge management within the phases of the maintenance process, coordination of the maintenance process with other processes (e.g. operation and modification processes) and a connection to strategic business objectives and external stakeholder requirements [26,27].

### 5. eMaintenance solutions

In the existing eBusiness environment, information and information systems have become critical maintenance support resources to achieve efficient information logistics.

There are extensive existing efforts that can be adapted to approach issues related to some of these needs. These efforts can be categorized in two groups: (I) generic efforts that are not specifically aimed at maintenance, but might be utilized for maintenance purposes and (II) specific efforts that are specifically aimed at eMaintenance.

Examples of generic efforts are: Essential Unified Process (EssUp), Rational Unified Process (RUP), Service-Oriented Architecture (SOA), Event-Driven Architecture (EDA), Web services, eXtensible Markup Language (XML), XMLSchema, Reference Model for Service-Oriented Architecture, Open Document Format, Microsoft .NET and Biztalk, IBM Web Sphere, Oracle BEA WebLogic and SAP Business suite.

Examples of more maintenance-specific efforts are: Product Life Cycle Support (PLCS), Production Planning and Scheduling (PPS), ISA-95, Open System Architecture for Enterprise Application Integration (OSA-EAI), Common Relational Information Schema (CRIS), condition monitoring and diagnostics of machines-data processing, communication and presentation (ISO 13374), the PROTEUS-platform, the concept of System for Mobile Maintenance (the SMMART-project) with focus on smart tags and wireless communication, tele-maintenance platform (TELMA), Technologies And Techniques for nEW Maintenance concepts (within the TATEM-project) with focus on monitoring technologies related to aviation, Maintenix (MXI Technologies), IFS Applications and SAP Service and Asset Management module within the SAP Business suite.

Some of these efforts contemplate support solutions from a business process perspective (e.g. RUP and EssUP), while others focus on technological aspects of service provision (e.g. OSA-EAI, PROTEUS, DYNAMITE and Maintenix). However, to enhance the information logistics related to maintenance support through appropriate information services, both the business process and related technologies need to be linked and aligned seamlessly (see the reasoning in Refs. [26–30]).

Furthermore, there are several existing contributions that deal with the establishment of eMaintenance from a SW architecture perspective. One contribution is the concept of a common database, i.e., an integration at the data level for provision of the needed flexibility for different working areas (e.g. maintenance), as support to strategic, tactic and operational decision making [31]. Another contribution is based on a client-server approach [32]. This client-server architecture is based on two subsystems: (I) a maintenance centre, which is intended to be tailored to the needs of the company through cooperation among the maintenance-related areas; and (II) local maintenance, which implements and evaluates the maintenance system provided by the

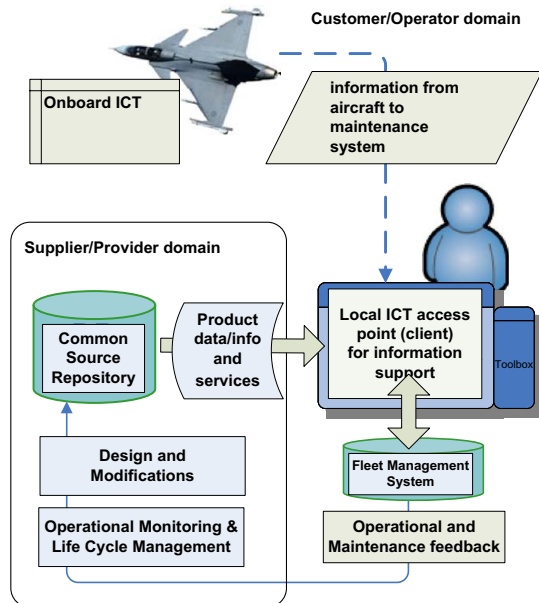

Fig. 4. Content sharing, service provisioning and feedback between supplier/provider and customer/operator domains.

maintenance centre. Another architecture approach relies on a star-like layered architecture [33,34]. One way to realize this star-layered architecture is to use a platform that utilizes the Web services (WS) technology upon the existing maintenance applications to provide function and data integration. However, the Web services technology is only one way to realize a Service-Oriented Architecture. An additional contribution is a proposed eMaintenance Management Framework, which is based on a service-oriented approach for the development of eMaintenance solutions [35].

However, when considering SW-related architecture it can be concluded that SW architecture has evolved from focused on server-computing to client-computing and during the last decades the focus has been changed to distributed computing. Distributed computing has been manifested through various approaches, e.g. client-server, object-oriented, component-based and service-oriented. The latest architectural approach is sometimes called “virtual computing”, which provides an abstraction level of distributed computer resources, e.g. disk spaces, SW applications and processor capacity. Examples of providers that offer support for virtual computing are: HP, Sun, IBM and Microsoft. See Fig. 5.

The latter contribution provided by Karim [35] is described in more detail in the following section.

**6. eMaintenance management framework**

One way to achieve this is through utilization of an eMMF, see Ref. [35]. As shown in Figs. 7 and 8, the eMMF is a meta-level model through which a range of technologies, methodologies and tools can be clarified and integrated. The main aim of an eMMF is to facilitate maintenance and to ensure its connection to overall business goals. The framework consists of two parts: the eMaintenance Management Model (eMMM) and the eMainte-

nance Platform (eMP). The eMMM is a package of roles, processes and repositories required for managing the eMP. The eMP is a Service-Oriented Architecture application, aimed to provide its stakeholders with tailored information for making decisions on the choice of appropriate maintenance activities.

An example of information services related to maintenance actors is the provision of Technical Publication (TP). In the context of Gripen, the TP is structured according to S1000D (see Fig. 6). However, one way to materialize information services related to TP is through two essential eMaintenance services. The first service, i.e., Maintenance Plan Delivery Service (MPDS), aims at delivery of the maintenance plan in a proper format, e.g., Portable Document Format (PDF), eXtensible Markup Language or Standard Generalized Markup Language (SGML). The second service, Maintenance Plan Feedback Service (MPFS), might be aimed at managing feedback from the utilization and support phases. The MPFS aims at the provision of a commenting and reporting capability related to content provided by MPDS on issues raised on data modules or publication modules during the verification process and the in-service phase of Gripen.

The eMP is divided into three levels: Specification, Design, and Implementation (see Fig. 8). The Specification level contains all the information necessary for conducting maintenance activities. It describes the identified requirements, which are realized in various ways using notations such as text and models. The Design level identifies design components that are needed to fulfil the requirements specified in the Specification level. This level is realized as service components. Finally, the Implementation level materialises the service components specified in the Design level into Web services and business processes orchestrated for specific needs. Each level consists of one or several groups of components. All components in the Specification level provide a platform for creating other components in the Specification level or they get directly realized on the Design and/or Implementation levels [37].

The eMP provides artefacts for supporting the maintenance process, e.g. situation-adapted information and services for performance support [4,5]. Further, SOA can be exploited

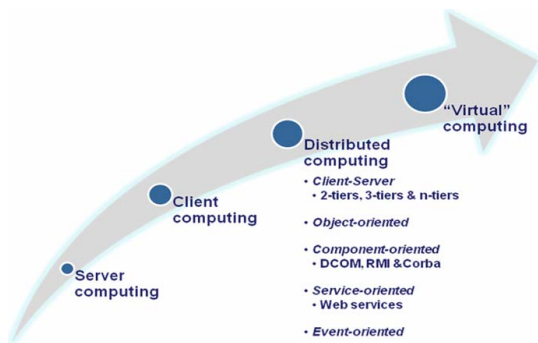

Fig. 5. The architecture maturity [35].

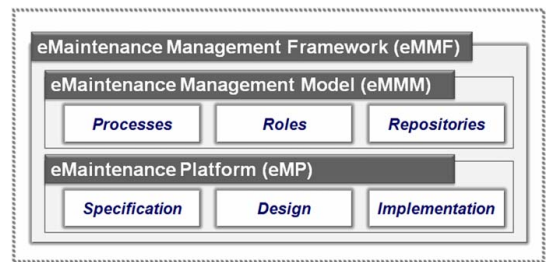

Fig. 7. Illustrating the components in the eMMF [37].

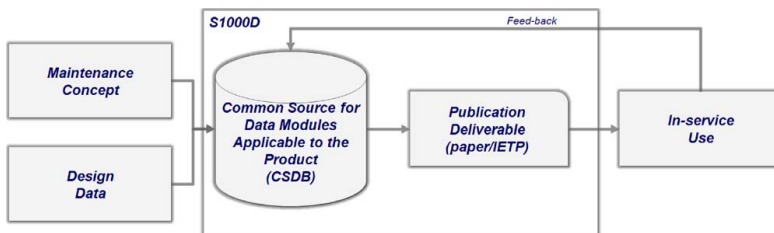

Fig. 6. The scope of s1000D [36].

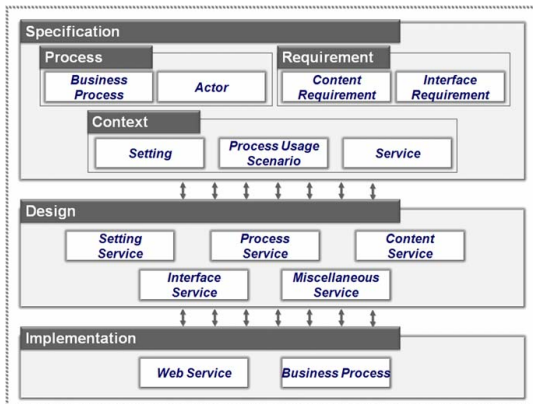

Fig. 8. Illustrating the substances in eMP [37].

in eMP. Hence, the eMP can be utilized to implement an eMP in organizations that provide maintenance of complex technical systems. The eMP is also most likely applicable in any organization providing maintenance, since it is based on a generic overall maintenance process.

The Specification level contains all the information necessary for conducting maintenance activities. It consists of three components: Process, Requirements and Context. The Process component lists and describes the business processes and actors involved in them. It consists of two parts: Business Process and Actor. The Context component lists and describes various backgrounds and their interrelated conditions in which maintenance activities take place. It consists of three components: Setting, Process Usage Scenario and Service. The Requirement component lists and describes all the functional and non-functional requirements on the information needed for a specific maintenance activity and the interface through which this information should be presented. It consists of two components: Content Requirement and Interface Requirement.

The Design level transforms most of the specification components into SOA components. The role of the Setting Service component is to design choreography for a certain set of services. The role of the Process Service component is to design a composition of miscellaneous services orchestrated for serving a particular process. The role of the Content Service component is to design services that implement logic for interaction with different data sources, such as existing systems or legacy systems. The role of the Interface Service component is to design services that handle/manage/wrap/adapt interface to other devices such as a portable handheld computer. For the exposition of services several technologies might be utilized, e.g. Distributed Component Object Model (DCOM), Remote Method Invocation (RMI) and Web services. If it is required to provide accessibility to the services via Hyper-Text Transfer Protocol (HTTP) over internet and data exchange through XML, Web services were selected as an appropriate technology. However, the service interfaces can be designed based on the Web services, which mean that using Simple Object Access Protocol (SOAP) envelope for information exchange. This implementation of services also provides the capability to expose a description of the signature of inherent public web methods, in accordance with the Web Services Description Language (WSDL) standard.

The Implementation level materializes the SOA components into the Web services and business processes orchestrated for the needs at hand. The Web Service component implements the SOA

components in the design level as Web Services. Web services technology is used to materialise these components, since they provide a generic interface for encapsulating logics and can be utilized as an intermediate layer to access legacy systems. The Business Process component corresponds to business processes as orchestrated for the needs at hand and delivered to the service consumer. In the context of eMaintenance, there is a need for both predetermined business processes and reactive business processes. To increase the effectiveness and efficiency in the implementation of services it is ought to be supported by a proper Interactive Development Environment (IDE) with capability to provide functionality necessary for team development, e.g. Microsoft .NET platform and IBM Web Sphere software.

## 7. Conclusions

The positive impact of eMaintenance is to be expected on two levels. One is the 'maintenance micro-level', where eMaintenance will serve as a performance support that facilitates hands-on execution of maintenance tasks by technicians, mechanics and support engineers, by providing a reduced number of interfaces to information sources, improved fault diagnosis, knowledge sharing and automated or facilitated procedures for technical administration. The other level is the higher 'maintenance macro-level', where eMaintenance will support managerial maintenance planning, preparation and assessment, enabling information-driven maintenance and support processes, and fleet-efficiency, e.g. aircraft maintenance programme evaluation, elimination of redundant information and operational monitoring. The impact of an eMaintenance implementation on aviation maintenance is of considerable potential as it enables a more efficient use of existing digital product information and design data over the whole life cycle.

There is also the challenge of going from a product-oriented to a service-oriented business strategy. A product-oriented strategy relies on a transaction/exchange marketing, while service-oriented emphasizes the relation between provider and customer. A service-oriented business strategy also demands the harmonization of support processes, such as the maintenance process, to the business's core process. The business's core process ought to be adaptable to the changes in the customers' value-generating process, and the business's supporting processes need to be adaptable to the core process. This change is facilitated by the proposed eMaintenance Management Framework and its SOA approach.

Since an eMaintenance platform's major purpose is to support the maintenance process, the components of the platform need to be considered from a service-oriented perspective in order to increase its adaptability to different parts of the maintenance and support process in different organizations. Hence, eMaintenance provides a platform for smart content sharing between information provider and information consumer. In this paper, the term-pair provider/consumer is used to emphasize that the ICT support to the maintenance process should adapt a process-centric approach, supporting efficient maintenance and support solutions. In a supplier/customer approach, the definition of the organizational boundary is important, which is not necessarily an issue of importance for delivery of maintenance information.

The maintenance process has to interact with a number of correlated processes in an enterprise, e.g. business, operation, information, support and logistics. Hence, a service-oriented eMaintenance platform should provide services that can be incorporated and orchestrated to the flow of these processes. While the requirements on the maintenance process vary over

time, the architecture of eMaintenance should be constructed to provide applicability and effectiveness.

With applicability and effectiveness as the two major requirements, it is clear that a Service-Oriented Architecture approach is a prerequisite for being able to design a solution which will provide applicable and effective eMaintenance services. Furthermore, it should be noted that a Service-Oriented Infrastructure is a prerequisite for implementing SOA. It is important to be aware of that Web services, and their related technologies, e.g. WS-BPEL, WS-Transaction and WS-Coordination, are not synonymous with SOA. SOA is a way of thinking that approaches the architectural issues and WS is a technology that is designed to facilitate the implementation of SOA.

We believe, based on our study of the effects of eMaintenance, that the eMaintenance platform, mainly through its improvement of different parts of the maintenance process, impacts on the dependability, safety and life-support costs of critical systems. Hence, our conclusion is that an eMaintenance Platform structured, designed and implemented from a service-oriented perspective with focus on the business process, increases the ability to fulfil requirements such as context-awareness, situation-awareness, seamless information integration between processes (e.g. operation and maintenance), improved knowledge-sharing, flexibility, extensibility and cost-reduction. Further, we can conclude that SOA as an approach and Web services as a technology can be utilized to implement service-oriented information services related to maintenance and its actors. Loosely connected maintenance services can, relatively, easily be re-composed and orchestrated to the new process, situation and context to better fulfil different stakeholders' requirements.

## Acknowledgments

The work presented in this paper has been carried out at the Division of Operations & Maintenance Engineering, Luleå University of Technology and Saab Aerotech, Linköping, Sweden. The authors would like to acknowledge the financial support of the National Aeronautics Research Programme (NFFP4) and the Aircraft Services Division at Saab Aerotech, as well as the valuable knowledge support from the Swedish Air Wing F21 in Luleå. We also thank Professor Uday Kumar for comments on drafts of this paper.

## References

- [1] Lee S, Maa Y, Thimm G, Verstraeten J. Product life-cycle management in aviation maintenance, repair and overhaul. *Computers in Industry* 2008;59(2–3):296–303 March 2008.
- [2] ISO/IEC-15288, Systems engineering—System life-cycle processes, International Organization for Standardization, Geneva. International Electrotechnical Commission: Geneva; 2008.
- [3] Markeset T, Kumar U. Design and development of product support and maintenance concepts for industrial systems. *Journal of Quality in Maintenance Engineering* 2003;9(4):376–92.
- [4] Candell O. Development of User Information Products for Complex Technical systems, licentiate thesis, Luleå University of Technology, Luleå, Sweden, 2004.
- [5] Saab. Internal document. Candell O. Maintenance WorkStation—MWS, Final Report, 2007.
- [6] Jensen, D. Special Report: TATEM: Europe's future view of maintenance. *Aviation Maintenance*, October 1, 2007.
- [7] Careless J. Airbus's new support strategy values customer service. *Aviation Maintenance*, 1 April, 2004.
- [8] IEV. International electrotechnical vocabulary (IEV). Available at: <<http://www.electropedia.org/>>, accessed: 18 August, 2008.
- [9] Sandberg A, Strömberg U. Gripen: with focus on availability performance and life-support cost over the product life cycle. *Journal of Quality in Maintenance Engineering* 1999;5(4):325–34.
- [10] Yoon K, Kim H, Sohn S. An air force logistics management index for effective aircraft operation. *Transportation Research Part E: Logistics and Transportation Review* 2008;44(6):1188–204 November 2008.
- [11] Nam JG. A study on Korea logistics information management. Technical Report, Korea National Defence University 25, Seoul, Korea; 2002; p. 257–316.
- [12] Fleischmann M, Bloemhof-Ruwaard JM, Dekker R, Van der Laan E, Van Wassenhove LN. Quantitative models for reverse logistics: a review. *European Journal of Operational Research* 1997;103(1):1–17.
- [13] Brooks JL, Wallace MG. Logistics support planning for standardized avionics. In: Proceedings of the IEEE Aerospace and Electronics Conference; 1989. p. 1929–36.
- [14] Saab. Requirements on system effectiveness, Saab Aerotech, 2007.
- [15] Ahlgren J, Christofferson L, Jansson L, Linnér A. Faktaboken om Gripen. 4th ed. Industrigruppen JAS; 1998 [In Swedish].
- [16] Lorell M, Raymer DP, Kennedy M, Levaux H. Grey threat: assessing the next-generation European fighters. Santa Monica, CA: Rand Corporation; 1995.
- [17] Söderholm P. Maintenance and continuous improvement of complex systems: Linking stakeholder requirements to the use of built-in test systems. Sweden: Luleå University of Technology; 2005 [Doctoral thesis].
- [18] Söderholm P. A system view of the no fault found (NFF) phenomenon. *Reliability Engineering and System Safety* 2007;92(1):1–14.
- [19] Smith D. HUMS Ascension. *Aviation Maintenance*, 1 February, 2008.
- [20] Candell O, Söderholm P. A customer and product support perspective of eMaintenance. 19th International Congress on Condition Monitoring and Diagnostics Engineering Management (COMADEM), Luleå, Sweden: 2006. p. 243–52.
- [21] Blanchard BS. *Logistics engineering and management*. 4th ed. Englewood Cliffs, NJ: Prentice Hall; 1992.
- [22] Pinet J. Human factors: a humanist and ethical approach to aeronautics. Part I/III. *Air & Space Europe* 2000;2(1).
- [23] OASIS. OASIS Product Life Cycle Support (PLCS) TC, available <[http://www.oasis-open.org/committees/tc\\_home.php?wg\\_abbrev=plcs](http://www.oasis-open.org/committees/tc_home.php?wg_abbrev=plcs)>, 2006.
- [24] W3C 2004. Sharable Content Object Reference Model, available <<http://www.w3.org/2004/04/webapps-cdf-ws/papers/SCORM.htm>>, accessed: 18 September, 2008.
- [25] Karim R, Söderholm P. Application of information and communication technology for remote support services: transferring experiences from an e-health solution in Sweden. *Journal of Quality in Maintenance Engineering* 2008.
- [26] Liyanage JP, Kumar U. Towards a value-based view on operations and maintenance performance management. *Journal of Quality in Maintenance Engineering* 2003;9(4):333–50.
- [27] Söderholm P, Holmgren M, Klefsjö B. A process view of maintenance and its stakeholders. *Journal of Quality in Maintenance Engineering* 2007;13(1):19–32.
- [28] Koc M, Lee J. A system framework for next-generation E-Maintenance Systems. In: Proceedings of the 2nd international symposium on environmentally conscious design and inverse manufacturing, 11–15 December, 2001, Tokyo, Japan; 2001.
- [29] Parida A, Kumar U. Managing information is key to maintenance effectiveness. In: Proceedings of the Intelligent Maintenance Systems (IMS) 2004 International Conference, 15–17 July, 2004, Arles, France; 2004.
- [30] Parida A, Phanse K, Kumar U. An integrated approach to design and development of e-maintenance system. In: Proceedings of VETOMAC-3 and ACSIM-2004, New Delhi, 6–9 December, 2004; 2004. p. 1141–7.
- [31] Kans M. On the utilisation of information technology for the management of profitable maintenance. Växjö, Sweden: Växjö University; 2008 [Doctoral thesis].
- [32] Han T, Yang B-S. Development of an e-maintenance system integrating advanced techniques. *Journal of Computers in Industry* 2006;57(6):569–80.
- [33] Bangemann T, Rebeuf X, Reboul D, Schulze A, Szymanski J, Thomesse J-P, et al. PROTEUS—creating distributed maintenance systems through an integration platform. *Journal of Computers in Industry* 2006;57(6):539–51.
- [34] Bangemann T, Reboul D, Szymanski J, Thomesse J-P, Zerhouni N. PROTEUS—an integration platform for distributed maintenance systems. In: Proceedings of the Intelligent Maintenance Systems (IMS) 2004 International Conference 15–17 July, 2004, Arles, France, 2004.
- [35] Karim R. A service-oriented approach to eMaintenance of complex technical systems. Sweden: Luleå University of Technology; 2008 [Doctoral thesis].
- [36] ASD. S1000D—International specification for technical publications: utilizing a common source database. AeroSpace and Defence Industries Association of Europe ASD and Ministries of Defence of the member countries of ASD 2008; 4.
- [37] Karim R, Kajko-Mattsson M, Söderholm. Exploitation of SOA within eMaintenance. In: Proceedings of the 30th International Conference on Software Engineering (ICSE), the 2nd international workshop on Systems development in SOA environments, 11 May, 2008, Leipzig, Germany; 2008.

## PAPER II

### Development of ICT-based Maintenance Support Services

Karim, R., **Candell, O.**, and Söderholm, P. (2009). Development of ICT-based Maintenance Support Services *Journal of Quality in Maintenance Engineering*, vol. 15, issue 2.





# Development of ICT-based maintenance support services

ICT-based  
maintenance  
support services

Ramin Karim and Peter Söderholm  
*Division of Operation and Maintenance Engineering,  
Luleå University of Technology, Luleå, Sweden, and*

Olov Candell  
*Aircraft Services Division, Saab Aerotech, Linköping, Sweden*

127

## Abstract

**Purpose** – The purpose of this paper is to describe a taxonomy for an eMaintenance management framework (eMMF) based on a service-oriented approach, in order to facilitate the development of information and communication technology (ICT)-based maintenance support services aimed at actors within the maintenance process related to complex technical industrial systems.

**Design/methodology/approach** – To fulfil this purpose, a case study of a modern multi-role combat aircraft is selected as an appropriate research strategy and supported by a literature study. Empirical data are collected through interviews, workshops, document studies, and observations. A framework is developed and evaluated using a prototype within the studied case. The study is performed in close cooperation with the aircraft's type certificate holder and the customer representative and operator in one country.

**Findings** – The proposed eMMF aids in the identification and development of ICT-based maintenance support services tailored for specific maintenance actors and their activities.

**Research limitations/implications** – To further test the usefulness of the proposed framework, a larger scale application must be performed. This can involve additional stakeholders or a larger part of the technical system in the selected case, or another case dealing with complex technical industrial systems.

**Practical implications** – The proposed framework supports the identification of required information services that support the maintenance process, which in turn supports the development of a service-oriented architecture (SOA) aimed at proper maintenance information logistics. Hence, people working with information logistics for maintenance purposes can use the framework as a support tool.

**Originality/value** – The proposed framework combines a process and service-oriented approach, which facilitates the development of SOA-based information services by giving valuable input to more traditional system-oriented approaches.

**Keywords** Maintenance, Communication technologies, Military aircraft

**Paper type** Research paper



First, the authors thank Saab Aerotech and the Swedish National Aeronautical Research Programme (NFFP) for supporting this work intellectually and financially. The authors also thank the SwAF Wing F21, a valuable source of knowledge. Finally, special thanks to Tommy Tyrberg at Saab Aerotech, Jan Johansson and Hans Öhlund at F21, and Laci Bonivart at FMV, who all have been enormous sources of inspiration. The authors would also like to thank Professor Uday Kumar, Assistant Professor Aditya Parida, and two anonymous reviewers for their valuable comments and feedback on drafts of this paper.

## Introduction

Maintenance may be seen as a process that monitors a technical system's capability to deliver services, records problems for analysis, takes corrective/adaptive/perfective or preventive actions, and confirms restored capability (Coetzee, 1998; Campbell and Jardine, 2001; Söderholm *et al.*, 2007; ISO/IEC, 2008). The purpose of the maintenance process is to sustain the capability of a system to provide a service and thereby achieve customer satisfaction (Liyanage and Kumar, 2003; Söderholm *et al.*, 2007; ISO/IEC, 2008). A generic maintenance process consists of phases for management, support planning, preparation, execution, assessment, and improvement (IEC, 2004). Hence, maintenance is multidisciplinary and involves a wide range of actors, such as managers, process owners, maintenance technicians, maintenance planners, and logistic managers. Therefore, to be efficient and effective, the maintenance process should be horizontally aligned with both the operation and modification processes and vertically aligned with the requirements of external stakeholders (Liyanage and Kumar, 2003; Söderholm *et al.*, 2007).

Simultaneously, actors within the maintenance process require support to perform their activities as intended. This maintenance support consists of resources such as documentation, personnel, support equipment, materials, spare parts, facilities, information, and information systems (IS) (ISO/IEC, 2008). Hence, the provision of the right information to the right information consumer and producer with the right quality and in the right amount of time is essential (Parida *et al.*, 2004; Parida and Kumar, 2004; Lee *et al.*, 2006). This desirable situation can be achieved through appropriate information logistics, which aims to provide just-in-time information to targeted users and to optimize the information supply process, i.e. making the right information available at the right time and at the right point of location (Heuwinkel *et al.*, 2003; Haseloff, 2005). Hence, information logistic solutions deal with four aspects (Heuwinkel *et al.*, 2003; Haseloff, 2005). The first aspect is time management, which addresses "when to deliver". The second aspect is content management, which refers to "what to deliver". The third aspect is communication management, which refers to "how to deliver". Finally, the fourth aspect is context management, which addresses "where and why to deliver".

However, it is a great challenge to achieve effective information logistics when dealing with maintenance of complex technical industrial systems. The reason for this is that maintenance-related information often is hidden in vast amounts of data, stored for other purposes, at different places, in different formats, and generated throughout the entire life cycle of the system (Tsang, 2002; Candell and Söderholm, 2006). At the same time, there is an ever increasing amount of data and information that may lead to data overload and information islands, which both contribute to unwanted maintenance-related consequences, such as reduced product quality, unwanted incidents, and accidents (Kletz, 1994; Ollila and Malmipuro, 1999; Holmgren, 2005, 2006; Holmgren and Söderholm, 2008). One reason is that data overload can cause problem in the actors' situation-awareness due to non-availability of the right information (Rasmussen *et al.*, 1994; Candell, 2004; Parida *et al.*, 2004). Simultaneously, information islands prevent the integration of information in an organization, e.g. information generated or stored within the operation, maintenance, and business processes (Parida *et al.*, 2004; Söderholm, 2007; Söderholm *et al.*, 2007). Owing to this challenging information context and increasing information needs, the development of information and communication technology (ICT) contributed in the early 2000s to the emergence of eMaintenance, which today is a common term in maintenance-related literature (Muller *et al.*, 2008; Levrat *et al.*, 2008).



Even though there are multiple views of what eMaintenance actually is, one common and vital part is the application of ICT to achieve effective information logistics within the maintenance area (Koc and Lee, 2001; Tsang, 2002; Parida and Kumar, 2004; Lung and Crespo Marquez, 2006; Muller *et al.*, 2008). Hence, the establishment of a dynamic and effective eMaintenance solution requires an appropriate software architecture. The software architecture involves a description of software systems' inherent elements, the interactions between the elements, their composition as guided by patterns, and the constraints on these patterns (Sowa and Zachman, 1992; Shaw and Garlan, 1996). One approach to software architecture related to eMaintenance is the concept of a common database, or an integration at the data level for provision of the needed flexibility for maintenance as support to strategic, tactic, and operational decision-making (Kans, 2008). Another approach to an architecture for eMaintenance is a client-server approach (Han and Yang, 2006). This client-server architecture is based on two subsystems. The first subsystem is a maintenance centre, which is intended to tailor the needs of the organisation through cooperation among the maintenance-related areas. The second subsystem is local maintenance, which implements and evaluates the maintenance system provided by the maintenance centre. Another approach relies on a star-like layered architecture (Bangemann *et al.*, 2004, 2006). One way to realize this star-like layered architecture is to use a platform that utilizes web services technology along with the existing maintenance applications to provide function and data integration (Bangemann *et al.*, 2004, 2006).

The aforementioned efforts related to software architecture within eMaintenance are complementary and contribute to the achievement of service-oriented information logistics within the maintenance area. Particularly, the use of web services technology is an attractive approach to achieving a dynamic and flexible eMaintenance solution based on a service-oriented architecture (SOA). In the context of software architecture, SOA represents an model where business logic is decomposed into smaller elements that can be distributed (Erl, 2006). One of the benefits of such elements is that they are autonomous and can be individually distributed (Newcomer, 2002; Erl, 2006; Pulier and Taylor, 2006). Another benefit is that these elements are unified by the term "service", in order to reduce their dependency on underlying technology and emphasize their target, the business processes (Erl, 2006; Pulier and Taylor, 2006). The Organization for Advanced Standards for Information Society (OASIS, 2008) describes SOA as a collection of best practices, principles, and patterns related to service-aware, enterprise-level, and distributed computing. Hence, SOA enables a higher degree of flexibility by disregarding any specific technology and instead focusing on the information services that are requested as support by the actors within a process.

Therefore, the purpose of this paper is to describe a taxonomy for an eMaintenance management framework (eMMF) that is based on a service-oriented approach, in order to facilitate the development of maintenance support information services aimed at actors within the maintenance process related to complex technical industrial systems.

The remaining outline of this paper is as follows. First, the study approach section contains a description of the applied research methodology. Then, a description of the studied case is provided in the case study description section. Thereafter, the section titled eMaintenance management framework provides a description of the proposed framework and aspects of its evaluation through a prototype development. Finally, the conclusions

---

and discussion section ends the paper by providing a summary and discussion of findings encountered in the study as a whole.

### Study approach

Based on criteria given by Yin (2003), a single-case study was selected as an appropriate research strategy (see Söderholm, 2005 for a further discussion about the rationale for this selection). To collect empirical data and simultaneously achieve a triangulation, multiple sources of evidence were applied, such as workshops, interviews, observations, and document studies. To initially arrange the findings of the case study and to reduce the number of them, some of the Seven Management Tools as described by Mizuno (1988) were applied. For example, in order to identify maintenance actors and their information requirements, process mapping has been applied, as advised by Juran (1992) and Sharp *et al.* (1999). The process perspective was also chosen to support a service-oriented approach, as advised by Zeithaml *et al.* (1990), Gummesson (2002), Bergman and Klefsjö (2003) and Grönroos (2007). This combined process and service-oriented approach is further believed to facilitate the development of SOA-based information services by giving valuable input to more traditional system-oriented development approaches (as described by Alexander, 1997; Sommerville and Sawyer, 1997; Kotonya and Sommerville, 1998). This combined approach was also applied in the iterative prototype development, as described in more detail in the section eMaintenance management framework. The purpose of the prototype development was to evaluate parts of the proposed eMMF. In addition, key informants have been used to review the validity of ideas and to create documents throughout the research process.

### Case study description

This section describes the studied case. First, a description of the aircraft is provided; thereafter, the organisations and selected actors involved in its maintenance are described in relation to applied maintenance echelons. Thereafter, the aircraft maintenance is described within a process view. Finally, certain aspects related to maintenance information and ICT-applications within the case study context are given.

#### *Technical system*

The Saab JAS 39 Gripen is a modern fighter aircraft designed to perform three mission types: interception, air-to-ground, and reconnaissance. As in other complex technical systems, the aircraft has a very intricate configuration. As illustrated on the left-hand side of Figure 1, it can be structured as a hierarchy of items, called indenture levels.

As illustrated on the right-hand side of Figure 1, the aircraft may be placed on the first indenture level. Its subsystems, such as the engine, are then placed on the second level. The engines' constituent items, e.g. the spraybar slots, are then placed on the third level. Finally, the spraybar is one example of an item on the lowest level.

Another method of looking at items from the maintenance perspective is illustrated on the right side of Figure 2. Here, the items are classified as line replaceable units (LRUs) or shop replaceable units (SRUs). From a maintenance perspective, this classification indicates the way that these items are maintained. Both LRUs and SRUs may consist of hardware and software parts.

The LRUs may be removed and replaced at the deployed site of the system, for instance, in the field. By doing this, one quickly restores the affected unit or its

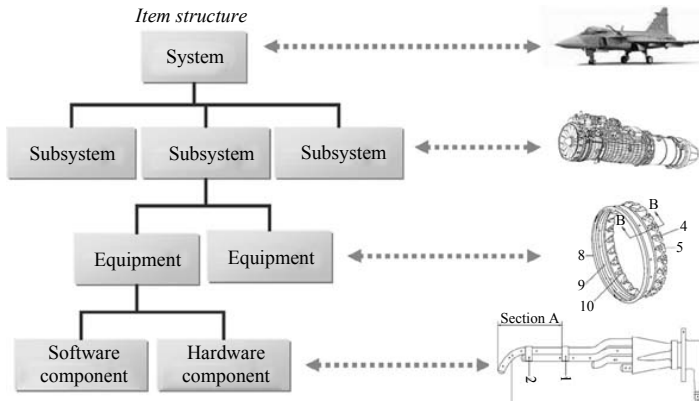

**Figure 1.**  
Indenture levels of a  
system

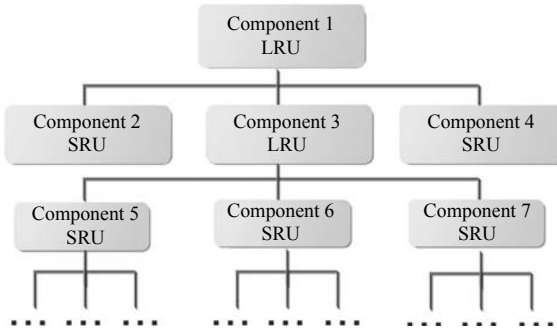

**Figure 2.**  
Structure of maintenance  
items

parent item to an operational condition. The SRUs, on the other hand, can only be attended to at a shop level. To attend to a faulty SRU, one must first remove its closest LRU parent from the aircraft, and then take it to a shop, where a technician gets inside the LRU to remove the faulty SRU.

### Maintenance organisation

In the Swedish case, there are mainly three organisations that are involved in the maintenance of the Gripen, each having different roles. Saab is the manufacturer and type certificate holder of the aircraft. The Swedish Defence Materiel Administration (Försvarets MaterielVerk, FMV) represents the customer (the Swedish Government) for the aircraft and the Swedish Air Force (SwAF) is its user.

Saab's role is to provide maintenance guidelines to its customers and users, as well as to perform highly specialized maintenance and modifications of the aircraft. FMV's (2008) role is to adapt Saab's guidelines to the context of the SwAF. The SwAF's (2008) role is to operate and maintain the aircraft according to the guidelines provided by Saab and FMV.

One way to illustrate the maintenance organisation is by functional area, such as management, planning, mechanical, and electrical. Another way is to use

maintenance echelons, which are organizational levels that perform maintenance activities, as seen in Figure 3. Their configuration is highly dependent on overall organizational policies, rules and regulations, technical system, indenture levels, maintenance programme, and overall requirements. Hence, the situation may vary entirely between different organizations.

The JAS 39 Gripen, operated by SwAF, is managed across three echelons. At Echelon 1, maintenance is conducted preventively at regular pre-determined intervals (e.g. calendar time, operation time or number of cycles) or correctively after having experienced a failure. Tasks performed here mainly concern replacement tasks that may be conducted directly on the aircraft. These include aircraft inspections, adjustments, calibration, cleaning and lubrication, and replacement. Maintenance at Echelon 1 is often conducted on aircraft in the operational environment.

Maintenance in Echelon 2 is conducted in fully equipped intermediate maintenance workshops. Here, one makes minor repair and attends to faulty SRUs by removing them from their parent LRU and replacing them with new SRUs. At Echelon 2, maintenance tasks performed are not suitable to be performed on aircraft or at Echelon 1, because of maintenance characteristics. At this echelon, one attends to LRUs that have been removed from the aircraft and transferred from Echelon 1.

Finally, maintenance in Echelon 3 is performed by highly specialized personnel at central workshops. This work involves not only complete rebuilding of entire items and renovation of major assemblies (such as aircraft engines), but also LRUs and SRUs received from the other echelons for delivery to item stock.

*Maintenance process*

The maintenance process of the Gripen may be described based on the six phases: maintenance management, maintenance support planning, maintenance preparation, maintenance execution, maintenance assessment, and maintenance improvement (Figure 4). Each such phase needs to be supported with timely information. This section describes each maintenance phase and some of its information needs.

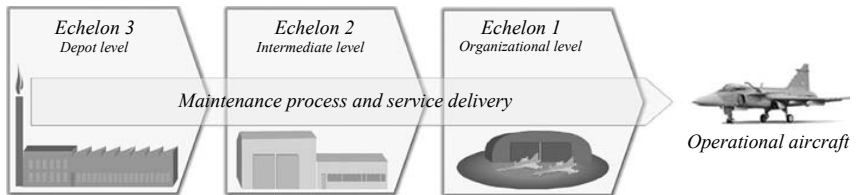

Figure 3. Maintenance echelons

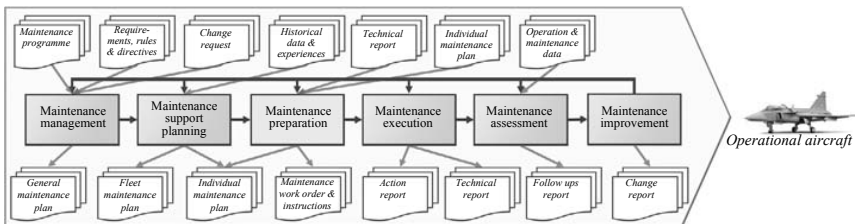

Figure 4. Example of aircraft maintenance process

The parts of the maintenance activities and related information flow that are related mainly to a Swedish Air Wing are shown in Figure 5.

*Phase 1. Maintenance management*

The first phase is called maintenance management, and is conducted at Echelon 3 by Saab, FMV, and various authorities, including certification and legal authorities. Using a set of rules, directives, and requirements from these bodies, as defined by the manufacturer in the maintenance programme, one creates a general maintenance plan defining guidelines and directives for how to maintain a certain variant of the Gripen. The contents of the general maintenance plan should apply to the entire aircraft lifecycle. It may, however, be changed in cases when changes are made either to the aircraft or maintenance policies. During this step, there is a need for access to information from many heterogeneous content sources. Some examples of these sources are domestic and international rules, regulations and standards related to maintenance, internal operational requirements, supplier directives and requirements, sub-contractors' and manufacturer's maintenance programmes, and system information.

These contents are provided from different organizations, in different content formats, at different times, and may have different lifecycles. The desired effect of information services is to offer improved information support in terms of access time, integration, monitoring and change management, as well as functionality for information exchange with external sources and tools for analysis and processing.

*Phase 2. Maintenance support planning*

In Sweden, the maintenance support planning phase is conducted at Echelon 3 by FMV. Here, FMV creates fleet maintenance plans defining maintenance of the SwAF's aircraft fleet and also creates plans for maintaining individual aircraft. Both plans include spare parts, personnel and their competence levels, tools, LRUs/SRUs, etc. They are created on the basis of historical facts and experiences as documented in the Historical Data & Experience document.

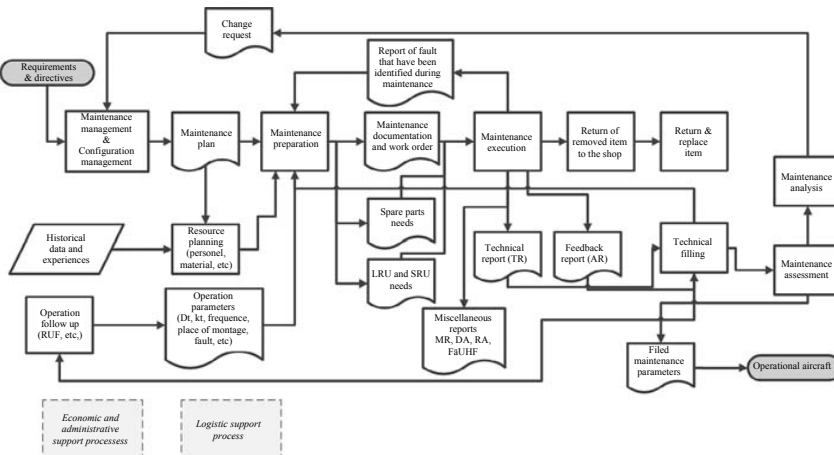

**Figure 5.** Maintenance activities and information flow mainly related to a Swedish Air Wing

To plan maintenance support, information from several information sources must be provided, for example, information managed in former phases and logistics information with respect to fleet, aircraft individuals, LRUs, and SRUs. In addition, historical information concerning the operation and maintenance, but also clear specifications of the maintenance actors and their competencies should be accessible.

*Phase 3. Maintenance preparation*

The maintenance preparation phase is conducted in Echelons 1, 2, and 3 by the user of the aircraft or industry. It is performed either at predetermined time intervals or after a failure has occurred. Here, the tasks to be conducted in the upcoming maintenance execution phase are planned. In the process, one considers each individual aircraft's operational conditions and problems that have been reported by the pilot during operation and by the support technicians during the maintenance execution phase. The outcome of this phase is a maintenance work order. This order specifies tasks to be conducted.

Since most of the maintenance tasks are planned preventive tasks, this phase involves information from several sources. Some of these are outcomes from the maintenance support planning phase, or the maintenance programme. In addition, one needs to access operational data (pilot and technician observations, alarms, and sensor data), historical data (data related to performed maintenance tasks on the individual aircraft), maintenance handbook, various logistic information regarding both the components and access to maintenance stations, and personnel information with respect to availability.

Both the maintenance preparation phase and the preceding maintenance support planning phase focus on the provision of information services that maximize the actors' efficiency and role capability. This is achieved through a reduction of time-consuming access to non-digital data sources, other actors, and manual interventions. Hence, information services are expected to enable actor independency through enhanced decision support that facilitates the identification of appropriate plans and actions in a particular context.

*Phase 4. Maintenance execution*

The maintenance execution phase is conducted at Echelons 1 and 2 by the SwAF wings. The goal is to keep the aircraft in an airworthy and operational condition.

The technicians perform maintenance tasks as designated in the maintenance work order. During and after this phase, the following results are generated:

- a new technical report giving an account of problems to be attended to by the maintenance preparation phase;
- an action report recording the performed maintenance tasks;
- change requests suggesting major changes to either aircraft design or maintenance programme; and
- the list of removed items sent to other echelons.

In addition to the outputs from the maintenance preparation phase, such as the maintenance work order, there is a need to access operational data, work orders, the maintenance handbook, logistic information, and personnel information. The desired functionality of ICT applications is to supply a single access point or computer

---

device for actors, i.e. a digital service desktop that provides several different support functions through one integrated usable interface. Through improved accessibility and usability of frequently used information and support functionality, this would provide performance support to first line operation and maintenance actors. It should comprise role-based and situation-adapted orientation, guidance, and task-oriented user information and support, and thereby offer a significantly improved information environment for users as compared to today's divergent multi-application environment of separated, single access points and devices.

#### *Phase 5. Maintenance assessment*

The maintenance assessment phase is conducted in Echelons 1, 2, and 3 by all three organizations involved within maintenance plus subcontractor organizations. This phase takes place after maintenance execution, to ensure that required function has been retained or restored. Its role is to assess the data collected during operation and maintenance, to check if stated requirements are fulfilled, and to make suggestions for improvements. These suggestions provide input to the maintenance improvement and maintenance preparation phases. Maintenance assessment requires most of the information, if not all, that is produced within the former phases. What actually is required and when depends on the type of assessment.

#### *Phase 6. Maintenance improvement*

The final phase, maintenance improvement, is conducted in Echelons 1-3 by Saab, FMV, and SwAF. During this phase, the improvements related to the maintenance process and working patterns are performed. Improvements related to the aircraft design and surrounding environments are reported in change requests and submitted to the maintenance management phase.

Maintenance improvement requires the same information as the maintenance assessment phase, or most of the information that is produced within the former phases. What actually is required and when depends on the type of improvement. The support and services enabling operational and maintenance data feedback from the execution, assessment, and improvement phases are especially important for operational and fleet monitoring, as well as life cycle management. Hence, the eMaintenance solution needs to comprise aspects of functions such as repositories, delivery, and infrastructure for data and information feedback.

### **Selected aspects related to maintenance information and ICT**

In the future, the SwAF is expected to be a more integrated part of the rest of the armed forces, as well as the society that it is expected to protect. Furthermore, the air force must cooperate with other national and international authorities, organizations, and companies to a larger extent in order to solve their tasks. An additional challenge is that there exist many large and complex systems within the armed forces, which in the future will be part of a much larger, complex, and dynamic system-of-systems. This change generates additional requirements for operators, maintainers, and developers. Simultaneously, individual systems are becoming highly digitalized, sensor rich, smaller (micro and nano scale), and supplied with ICT. In addition, ICT development supports unmanned and autonomous vehicles (FMV, 2005; Candell and Söderholm, 2006).

The ICT development trends affecting maintenance solutions within the military aerospace area (and that are likely to impact system structures) are primarily the complication of additional hardware and software components due to the growth of on-board monitoring and built-in test (BIT) technologies for diagnostic and prognostic purposes. This technology development can also enable the aircraft to keep track of and digitally communicate information about its own system configuration (both hardware and software) to external, ground-based maintenance equipment and IS.

The echelon concept *per se* is not necessarily changed by a more pervasive ICT presence. However, the utilization of ICT can enhance information exchange and enable solutions such as overarching echelon integration of on-board monitoring and BIT with workshop level testing for LRU and SRU maintenance. This is likely to positively impact the no fault found problem, which can erode any benefits that on-board monitoring and BIT technologies by themselves may provide (Hawkins, 2006; Söderholm, 2007).

The Gripen user IS is based on data and results from the logistic support analysis (LSA) performed during the design phase of the maintenance system. The LSA defines support activities, maintenance tasks, ground support equipment, training needs, and provision for technical documentation. The LSA results, in the form of data and information, are integrated into a dynamic supportability database known as the Logistic Support Analysis Records or Integrated Logistic Support DataBase (ILS-DB). This database then becomes a central configuration-controlled and change-managed product data repository, continuously updated during the in-service phase to support the improvement of the maintenance system and the aircraft. This information is turned into user information in a suitable format. This is achieved by a process of structuring and adaptation of information and media to different actors and contexts.

The actors that use and raise requirements for information are a heterogeneous group representing many different professional disciplines. This group ranges from conscript aircraft mechanics and aircraft technicians performing on-aircraft maintenance, maintenance planners, as well as civil and military maintenance planners and engineers at the development organisation, sub-suppliers, and third party spares and maintenance suppliers.

Recently, typical actors in need of information for performance of activities within the maintenance process have access to the information in a multi-application environment with little or no integration of information providers, such as fault localization support equipment, amendment services, health monitoring and feedback of operational data, and maintenance records. By striving towards better composed and more integrated ICT-solutions and state-of-the-art tools (in a way that gives the actors a smooth information flow between different tasks and applications), and time for troubleshooting and maintenance activities, the need for paper-based documentation will be eliminated and costs will be reduced.

By observing the information needs in the maintenance process' inherent phases, some important challenges begin to crystallize. One challenge is related to information harvested from a large number of heterogeneous information sources. This includes aspects such as identification of the right information sources, access to the content source, delivery of the required data, aggregation of data to the required level, authentication and authorization of actors, and visualization of information to the right consumer.

The publication suite related to the Gripen is a vital source of information that supports maintenance execution. This information is tailored to fit the role and situation of a general



aircraft technician. This category of technician replaces the previous concept where several different types of technicians were specialized in disciplines such as engines, avionics, and weapons. Another requirement of the publication suite is to support the Swedish model of using semi-skilled conscripts (non-commissioned personnel) as aircraft mechanics. Together, with other supports (e.g. BIT), the tailoring of the maintenance publication is intended to simplify and make flight line operation and organizational level maintenance more effective while using less resources.

The daily operation of the aircraft is supported by maintenance performed on the flight line or in local workshops and on site at an air wing. Organizational level maintenance is performed by aircraft technicians and conscript aircraft mechanics who perform on-aircraft service and maintenance, while working with the entire aircraft. At intermediate and depot levels, maintenance workshops often employ civilian technicians and engineers, and the maintenance is both made on-aircraft and off-aircraft, i.e. on LRUs and SRUs removed from the airframe. This context defines a group of actors that is a mix of military and civilian technicians at the organizational, intermediate, or depot levels, but is also related to the whole aircraft or its inherent LRUs and SRUs.

To gain an understanding of the immense volume and complexity of the Gripen maintenance publication suite, the structure of one of its many included documents is shown in Figure 6.

The technical publication related to the Gripen is structured according to S1000D (Figure 7), which is an international specification for the procurement and production of technical publications (ASD, 2008).

Regarding content requirements, the supply-chain related to Gripen includes a vast number of customers and suppliers, and for most of them, it is not possible to afford special infrastructure and interfaces. Instead it is desirable to achieve standardized networks that may provide a secure infrastructure for exchanging standard transactions. Hence, Saab participates in industrial efforts for the deployment of international standards for ICT-facilitated product data exchange. For example, the ISO Standard 10303-239:2005 “Product data representation and exchange” and its Part 239: “Application protocol: product life cycle support”, specifies so-called Data Exchange Specifications (DEX), which enables structured data exchange and sharing to support complex engineered assets through their entire life cycle (OASIS, 2006). The Swedish Defence Materiel Administration (FMV), which represents the Swedish Gripen customer, has also made a strategic decision to use the PLCS standard to align their product data management. The main purpose of this decision is to cut costs, simplify processes, increase quality, and to secure the ability to manage and utilize product data for systems with very long life cycles (FMV, 2006). Simultaneously, the Swedish Armed Forces has decided to implement SAP, in order to have one standardised business system and thereby achieve better and more cost-effective methodologies within the areas human resources, economy, logistics, and control (IBM, 2008).

### **eMaintenance management framework**

The proposed eMMF consists of two parts: the eMaintenance management model (eMMM) and the eMaintenance platform (eMP). The eMMM is a package of roles, processes, and repositories required for managing the eMP. The eMP, on the other hand, is a SOA-application aimed at providing its stakeholders with tailored

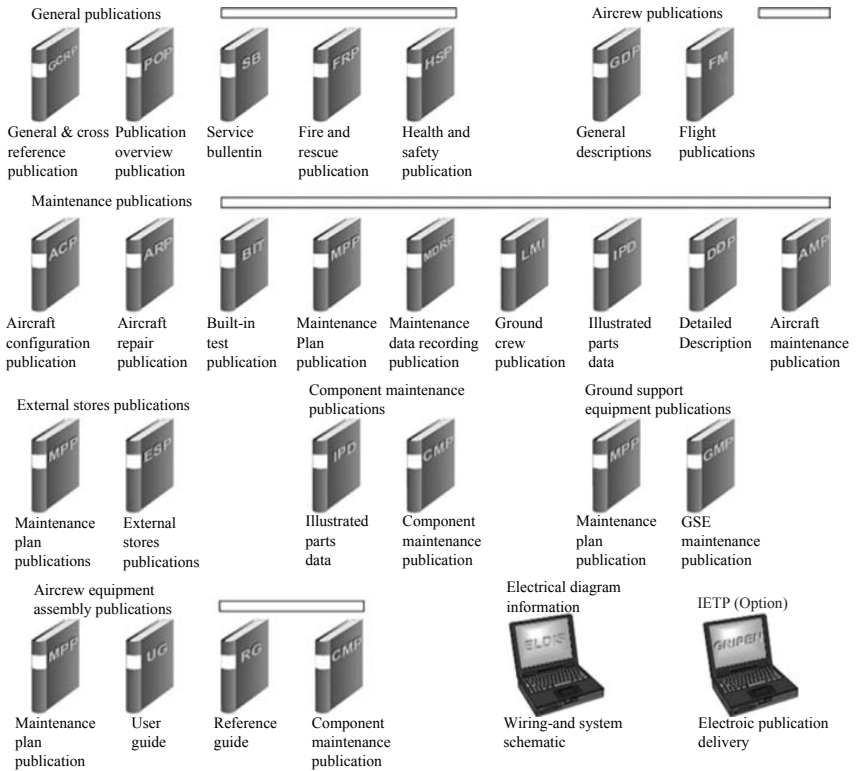

**Figure 6.** Illustration of the amount of information inherent in the maintenance programme

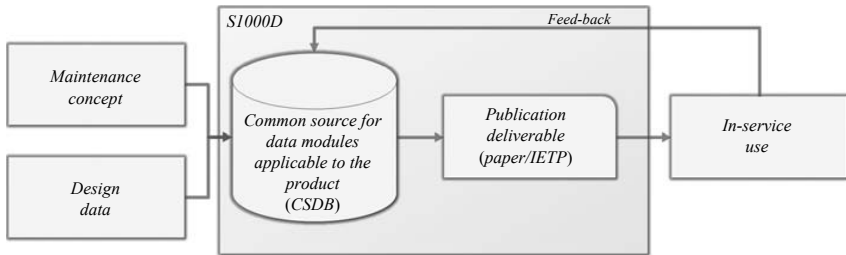

**Figure 7.** The scope of S1000D

Source: ASD (2008)

information pivotal for making decisions as to the choice of appropriate maintenance activities. Its purpose is to extract all of the information necessary for a certain maintenance activity, and to analyze, synthesize, and package it into a maintenance process relevant for the maintenance activity at hand.

---

### Maintenance service development – MSD

The proposed maintenance service development process (MSD) consists of five interconnected phases: maintenance service identification, maintenance service design, MSD, maintenance service implementation, and MSD. The aim of the MSD is to provide a generic process for development of maintenance support services.

A maintenance service is a set of linked functions which realizes a business objective or policy goal. During Maintenance Service Identification, services that are needed by a customer or user organisation, and can be provided by a supplier organisation (industry) through a maintenance solution, are identified. These solutions range from traditional spare parts provisioning to concepts such as turnkey solutions, total care, and functional products, where the customers can be offered availability performance to a fixed price. One example of a high degree of industrial commitment is the requirement of a “maintenance free operating period”, which may be included in service contracts within military aviation. In fact, a global trend is that the industry, to an increasing degree, provides services that traditionally have been carried out by the users. Examples of maintenance services are: “Support to customer 24/7”, “Support to product 24/7” and “Maintenance self service”. See also Markeset (2003), Markeset and Kumar (2003), Kumar and Kumar (2004), and Kumar *et al.* (2004) for a discussion about different types of maintenance services and solutions.

In order to evaluate the MSD phase in the eMMF, a number of activities have been conducted to elicit maintenance-related requirements in relation to the prototype development, including literature study, workshops, interviews, and document studies (for further description of maintenance requirements and services related to Gripen, see Candell and Karim, 2008; Karim *et al.*, 2008a, b). Based on the data collected within these activities, the maintenance process related to the Gripen has been mapped, which is described in the section Case study description. In addition, some of the overarching requirements that both present and potential customers of Gripen have stated more or less formally have been identified and related to the mapped maintenance process. This mapping can be based on formal textual and graphical modelling notations such as business process modeling notation (BPMN), integration DEFinition (IDEF), and object role modeling (ORM).

Based on the process map and the identified customer requirements, some vital maintenance services have been identified, such as the provision of technical publications (TP) and the management of operational data. Out of these, the provision of TP was selected as a candidate service for further development in the prototype. The three main reasons for this selection were that:

- (1) information in the TP is essential for all phases of the maintenance process;
- (2) TP is used by different maintenance actors in heterogeneous contexts; and
- (3) the content of TP is important for both Saab and its customers.

Hence, the selected service “provision of TP” was further used to evaluate the proposed eMSD process.

### eMaintenance service development – eMSD

The proposed eMaintenance service development process (eMSD) consists of the six phases: eMaintenance service identification, SOA component identification, SOA component design, SOA component development, SOA component implementation,

---

and SOA component deployment. The objective of eMSD is to use a service-oriented approach and to realize the ICT components that previously have been identified in the MSD. The eMSD is initiated as a part of the maintenance service implementation and gives input to the maintenance service deployment. During the eMaintenance service identification, the context and correlation of information services that support maintenance actors in the performance of their activities are identified and described. During the SOA component identification phase, the components needed from an ICT-perspective are determined. The SOA component design and development phases describe how the candidate components can be composed and materialized, and also what technologies should be used. In the SOA component implementation phase, the service components are implemented in the intended maintenance support service. Hence, in this phase, the ICT-components are tailored with the other artefacts included in a maintenance support service. The SOA component deployment phase results in the delivery and deployment of the ICT-service components to the intended context.

In order to evaluate the eMSD part of the eMMF, the selected service (provision of TP) from the MSD was processed in accordance with the proposed eMSD. To guide this work, S1000D, which is an international specification for TP, was followed (Figure 7). The selection of S1000D was mainly based on two criteria. The first criterion is that S1000D is a common and widely accepted guideline within aviation, and the second criterion is that Saab has chosen to adapt to S1000D.

Based on existing requirements regarding content format, it was noted that the efficiency of the service “provision of TP” could be increased through utilization of ICT. Hence, the output from MSD was used as input to the eMSD phase of the eMMF, for realisation of SOA-based services. Based on the output from the MSD phase, two eMaintenance services were identified for implementation based on an SOA-approach. The first service was maintenance plan delivery service (MPDS) and the second service was maintenance plan feedback service (MPFS) (Figure 7).

The MPDS is aimed at delivery of the maintenance plan in a proper format, such as Portable Document Format, eXtensible Markup Language (XML), or Standard Generalized Markup Language (SGML). The selection of format for content delivery was based on existing customer requirements. In addition, XML and SGML enhance the flexibility of processing content automatically, which contributes to increased usability of the content.

The MPDS enables customization of content format and inherent data depending on current context. The content is structured according to S1000D with some adaption to Saab’s requirements and conventions. The original data are gathered from several business applications, such as Pumax, which can be considered as a content management system, and the ILS database, which contains IL-related data (e.g. material structure and related maintenance needs).

The MPFS is aimed at the provision of a commenting and reporting capability related to TP on issues raised for the data modules or publication modules during the verification process and the in-service phase of the Gripen. This service also utilizes recommended guidelines for commenting in accordance to S1000D.

For realization of MPDS and MPFS, some of the eMP’s inherent items have been utilized. These are described in the eMaintenance platform – eMP section.

**eMaintenance platform – eMP**

The eMP is divided into the three levels: specification, design, and implementation (see right hand side of the bottom part of Figure 8). The specification level contains all the information necessary for performing maintenance activities, and realised in various ways using notations such as text, models, and related items. The design level identifies design components, which are realized as SOA-components. Finally, the implementation level materializes the SOA components into web services and business processes orchestrated for the needs at hand.

As shown in Figure 8, each level consists of one or several groups of components, and there exists a relationship between these components. All components in the specification level provide a platform for creating other components in either the specification level or they are directly realizable on the design and/or implementation level. This relationship is shown in Table I. Below the levels, their inherent groups of components and their relationships to other components are presented, as shown in Maintenance service development – MSD, eMaintenance service development – eMSD and eMaintenance platform – eMP sections. In addition, each eMP constituent is listed in Table I as well as a summary of how it is realized on each eMP level.

*Specification level*

The specification level contains all information necessary for performing maintenance activities. It consists of three components: process, requirement, and context.

*Process*

The process component lists and describes the business processes and the actors involved in them. It consists of two parts: business process and actor.

The business process is a prescriptive model of the organizational maintenance processes. It identifies and defines all of the generic maintenance processes inherent in maintenance. Each process is described in terms of its phases, activities,

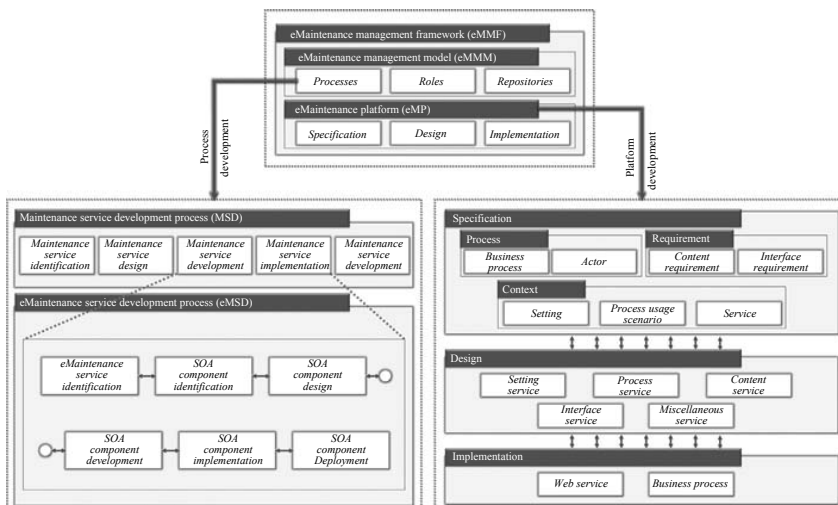

**Figure 8.**  
Structure of eMMF

**Table I.**  
Relationships among the  
eMP components

Components	Specification levels	Levels	
		Design level	Implementation level
Business process	Text, formal modeling language, etc.	–	–
Actor	Text, formal modeling language, etc.	–	–
Setting	Text, formal modeling language, etc.	Setting service	Web services (choreography)
Business usage scenario	Text, formal modeling language, etc.	Process service	Web services (orchestrated)
Service	Text, formal modeling language, etc.	Miscellaneous service	Web services
Content requirement	Text, formal modeling language, etc.	Content service	Web services
Interface requirement	Text, formal modeling language, etc.	Interface service	Web services and other UI implement

and relationships to other processes. For example, it may describe an immediate corrective maintenance action on a combat aircraft as executed by a maintenance technician, and its relationship to the maintenance preparation process as conducted by a maintenance planner.

Business process is an essential component of eMP since it provides a generic platform for defining the overall system architecture, for identifying business process flows to be supported by SOA, and for designating system boundaries. As shown in Table I, it is realised as text and/or various models on the specification level. It does not result in any SOA component on the design level. However, it constitutes a starting point for identifying and defining SOA components.

Regarding the actor, this is a descriptive model of the players involved in the business processes, and thus identifies and defines all the actors involved in the maintenance process. Actors are defined as things or people that are outside the system and interact with the system to achieve some goal (Jacobson, 1992; Bittner and Spence, 2003). The actors may represent people, organizations, systems, or devices involved in, or required for, executing a specific maintenance activity. Examples of people actors are pilots, technicians, system engineers, and maintenance planners. Examples of organizational actors are client and supplier organizations. Examples of system actors are IS containing information relevant for the maintenance activities (e.g. BIT systems that aid in fault diagnosis of an aircraft engine). An example of a device actor is a mobile maintenance workstation delivering maintenance support information to the maintenance technician. Further examples of people and organizational actors that interact with the BIT-system in the Gripen can be found in Söderholm (2006).

Just as in the business process component, the actor is an essential component of the eMP providing a platform for defining the overall system architecture, for identifying business process flows to be supported by SOA, and for designating system boundaries. For this reason, as shown in Table I, it is realised as text and/or various formal modelling languages on the specification level, such as BPMN, ORM, IDEF, and UML. It does not result in any specific SOA component on the design level.

Within the scope of the prototype, the description of business processes and its actors were limited to those scenarios that require a direct interaction with TP.

---

Example of the described usage scenario is the business process of maintenance planning based on the scheduled time cycles (involving actors such as maintenance planners) of the maintenance process for the Gripen. For a description of processes and actors, different notations are available. In prototype development, a option based on UML was selected. The reason for selecting UML as an appropriated modelling language for this context is that it provides a widely accepted description alternative based on graphical and textual visualization, which also is supported by numerous software development methodologies, e.g. rational unified process and essential unified process.

### *Context*

The context component lists and describes various backgrounds and their interrelated conditions in which maintenance activities take place. It consists of three components: setting, process usage scenario, and service.

The setting component is a description of specific situations, circumstances, or states in which maintenance tasks are performed. It determines the design of a maintenance task. Examples of certain settings are:

- war or peace time;
- a situation when the failure is evident or hidden for the operating crew;
- an “on aircraft” setting indicating that the maintenance is conducted at the LRU level;
- an “off aircraft” setting indicating that maintenance is conducted at the SRU level;
- “on road base” indicating that the maintenance is conducted at a dispersed road base on an organizational level; or
- “in shop” indicating that the maintenance is conducted in a shop at an intermediate or depot level.

Setting is a determinant in identifying and defining a set of process usage scenarios. It is proposed that a setting is described from a service-oriented perspective and not from a functional one. By this, it is meant that the description should focus on the services needed to fulfil a process rather than the functions required to perform a task. As shown in Table I, a setting is realized as text and/or various formal modelling languages, mentioned earlier, on the specification level. It results in a SOA component on the design level, which is called a setting service. Finally, it is implemented as a web service at the implementation level.

Process usage scenario identifies and describes different maintenance scenarios. A scenario is a model of an expected or existing sequence of activities required for conducting a certain process. It corresponds to a description of one instance of a business process (as specified in the business process constituent) to be performed in a given setting (as specified in the setting constituent). An example of a process usage scenario is a description of how to conduct an inspection of an aircraft in peace time. Further examples of usage scenarios related to maintenance of the Gripen can be found in Candell (2004). As shown in Table I, business process is realized as text and/or various models on the specification level. Within the design level, it is realized as a process service. Finally, in the implementation level it is realized as a web service.

The service component identifies and describes the existing services to be used within a specific maintenance scenario. An example of a maintenance service is a description of how to replace an aircraft engine. It focuses on the services as a ordered

---

collection of service components and its interface to the process. It is proposed that this description is based on a service-oriented approach. Within the specification level, it is realized in various ways, such as text and formal modelling languages (Table I). At the design level, it is realized as a miscellaneous service and at the implementation level it is realized as a web service.

Within the prototype development, the selected contexts were described based on the information need related to the content of TP. Examples of these contexts are the provision of preventive maintenance tasks according to the maintenance plan within the context of on-aircraft maintenance, and the provision of maintenance tasks within the context of storage maintenance (maintenance of LRUs and SRUs that are kept in storage). Another context is when a LRU is removed from storage and taken into operation, where it becomes necessary to have information available to estimate the LRU's remaining time to next preventive maintenance action (e.g. flight hours or cycles) by considering both the passed storage time (calendar time) and the remaining operational time (flight hours or cycles). The descriptions of the selected contexts were provided mainly in textual form.

### *Requirement*

The requirement component lists and describes all the functional and non-functional requirements of the information needed for a specific maintenance task and the interface through which this information should be presented. It consists of two components: content requirement and interface requirement.

The content requirement component is a detailed specification of the information needs and requirements for performance of actions in a process. It identifies the information needed for a particular maintenance task. For example, in order to perform engine inspection, a maintenance technician may need to access information about operational data from the engine, maintenance manual, technical documentation, and current work order.

Content requirement provides a basis for designing a service on the design level whose role is to determine the IS nodes providing relevant content to the business processes. Within the design level, it corresponds to a SOA component, which is called a content service.

The interface requirement component identifies the interfaces required for a particular maintenance task. The interfaces correspond to both interface devices through which communication between the actors takes place and the formats of how the information should be presented to a specific actor via a specific device. An example of a device is a handheld portable computer that communicates through a wireless infrastructure. An example of a format for delivering content to the device is XML. Within the specification level, the interface requirement component is realized in various ways: text, models, and other notations. Within the design level, it is realized as interface service. Within the implementation level, it is realized as either a web service or another user interface implementation.

In the prototype, the requirements related to content and interface have been identified and described within the scope of selected services and contexts. The data for these descriptions have been collected through literature study, interviews, workshops, and document studies. The selection of proper technologies, standards, and recommendations related to content format and interface for information access has been performed through review and evaluation of available and applicable relevant efforts for the specific case study, such as PLCS and S1000D.



---

*Design level*

The design level transforms most of the specification components into SOA components. These components have already been identified in the former section. However, for clarity reasons, these SOA components are once again listed and briefly described:

- The setting service component, which has the role of designing choreography for a certain set of services and covers information/properties/parameters relevant for a certain setting.
- The process service component, with a role of designing a composition of miscellaneous services orchestrated for serving a particular process.
- The miscellaneous service component, with a role of designing services that encapsulate the majority of the business logic that has not been covered by the above-listed services.
- The content service component, with a role of designing services that implement logic for interaction with different data sources, such as existing or legacy systems.
- The interface service component, with a role of designing services that handle/manage/wrap/adapt interfaces to other devices, such as a portable handheld computer.

The SOA components included in the prototype have been structured in accordance with the proposed design level of the eMP. For exposition of services, several technologies have been available, such as distributed component object model, remote method invocation (RMI), and web services. Because there was a requirement to provide accessibility to the services via HyperText Transfer Protocol (HTTP) (over internet and data exchange through XML), web services was selected as an appropriate technology. However, the service interfaces are designed based on the web services, which means that the services' public interfaces are exposed through HTTP and that they use the Simple Object Access Protocol envelope for information exchange. Each service has been assigned a namespace that denotes the type of service. The namespaces are defined according to the proposed design pattern in the design level, i.e. setting, process, miscellaneous, content, and interfaces. A service might require information from another service for instantiation.

*Implementation level*

The implementation level materializes the SOA components into the web service and business processes orchestrated for the needs at hand.

The web service component implements the SOA-components in the design level as web services. Web services are used because they provide a generic interface for encapsulating logics and can be utilized as an intermediate layer to access legacy systems. The web services specified herein focus on the content which a service delivers and not on its visualization to its actors. An example of web services is "get current work order", which can be invoked within a certain instance of a business process.

The business process component corresponds to business processes as orchestrated for the needs at hand and delivered to the service consumer. In the context of eMaintenance, there is a need for both predetermined business processes and immediate business processes.

The predetermined process corresponds to an orchestration of services that have been identified in advance by the process planners. It supports a set of repeatedly

occurring maintenance needs. An example of such a business process is the process of managing a support order from the time it gets reported by a pilot until it gets attended to by a maintenance technician. The business process provides guidelines for what to do. In this case, it suggests that the support order (technical report, in Saab's parlance) leads to a work order delivered to a maintenance technician, who then initiates a maintenance action. After the action gets completed, the business process suggests that the technician sends a report to the pilot and terminates the process.

The immediate business process, on the other hand, corresponds to an orchestration of services at runtime. It supports the maintenance needs that have been identified on the fly as a certain need arises. For instance, while inspecting an aircraft, a maintenance technician encounters an unusual problem, which he does not know how to approach. To find out what to do, the technician provides relevant input to the eMP. The eMP analyzes the problem and provides a suggestion to the maintenance technician in the form of a business process orchestrated to the problem at hand. Depending on the problem severity and urgency, the business process either provides instructions for how to attend to minor and less severe problems, or it suggests that the LRU should be sent to Echelons 2 or 3 for repair.

In prototype development, the identified and selected SOA-services were designed and adapted to web services. In order to develop and implement the designed web services effectively, an integrated development environment (IDE) has been used. For this purpose, several IDEs have been available, but based on the experiences and knowledge in the development team, Microsoft Visual Studio.NET 2008 was considered as appropriate. It should be emphasized that even though the web services are implemented in the selected IDE, they are accessible from any other environment that provides web services capability. The data processed by the web services in the prototype are managed through Microsoft Sql Server 2005 with XML capability. However, other Data Base Management Systems could have been used as well. The main reason for using Microsoft Sql Server 2005 is that it provides a tight integration with the selected IDE and thereby reduces the complexity of the development process.

### **Conclusions and discussion**

In this paper, a taxonomy for an eMMF is presented based on a service-oriented approach. The framework supplies guidelines and processes for development of information services that are intended to support maintenance of complex technical industrial systems.

The presented framework consists of two complementary parts that each addresses one of two critical issues of the problem. The first issue is how to merge the process of information services and business-services development, which is addressed through an eMMM. The other issue is how to define and describe a structure for service implementation, which is addressed through an eMP.

The eMMM is a package of processes, roles, and repositories derived from a generic maintenance process, and required for managing the eMP. Since there is a lack of available methodologies to support the information service development, i.e. identification of ICT-based information services from a business perspective, the focus has been on the processes part of the eMMM. This process part has been further decomposed into an MSD and an eMSD, an approach that enables the eMMM to support the identification and development of ICT-based maintenance support services tailored for specific maintenance activities.

The eMP in turn addresses the development of identified maintenance support services as information services (e.g. a set of web services). Hence, the eMP is to be viewed as a SOA-application, providing its stakeholders with tailored information for, e.g. important decision-making or analysis.

During this study, some challenges that an SOA-based eMaintenance solution must deal with are identified, such as the need for lifecycle management of both content and related software, need for configuration awareness, alignment of maintenance and product development, overall integration architecture, security, management of content format and its structure, overall service architecture, and the need for context and situation awareness. However, there are also some available guidelines and support in the form of well-established standards within both the dependability and the information domains, such as ASD's suite of ILS standards, IEC's dependability standards, and OASIS's open information standards.

The purpose of the prototype development was to evaluate parts of the proposed eMMF. The evaluation has shown that the eMMF can be used within military aviation. However, it is believed that many of the findings also are valid for other complex technical industrial systems, such as those within the civil aviation, railway, and power industries. To further validate the proposed framework, a larger scale application has to be performed, regarding both the framework (considering roles and repositories of the eMMM) and its application (a larger part of the studied system or some other complex technical industrial system).

The information requirements of the maintenance actors identified in the performed process mapping indicates that there is a need for information supports that are more coherent and adaptable for different actors and contexts. The maintenance and information support must also be adaptable to support operations with different organizational resources and role structures, in order to meet customer specific ambitions, capabilities, and requirements. Another important area for improvement is the capability to manage feedback on provided information, via the TP, for example.

The combined process and service-oriented approach is believed to facilitate the development of SOA-based information services by giving valuable input to more traditional system-oriented approaches.

## References

- Alexander, I.F. (1997), "A historical perspective on requirements engineering", *Requiraenautics Quarterly: The Newsletter of the Requirements Engineering*, Vol. 12 No. 3, pp. 13-21.
- ASD (2008), *S1000D – International Specification for Technical Publications: Utilizing a Common Source Database*, AeroSpace and Defence Industries Association of Europe – ASD and Ministries of Defence of the Member Countries of ASD, Issue 4.
- Bangemann, T., Reboul, D., Szymanski, J., Thomesse, J.-P. and Zerhouni, N. (2004), "PROTEUS – an integration platform for distributed maintenance systems", *Proceedings of the Intelligent Maintenance Systems (IMS) 2004 International Conference, Arles, 15-17 July*.
- Bangemann, T., Rebeuf, X., Reboul, D., Schulze, A., Szymanski, J., Thomesse, J.-P., Thron, M. and Zerhouni, N. (2006), "PROTEUS – creating distributed maintenance systems through an integration platform", *Journal of Computers in Industry*, Vol. 57 No. 6, pp. 539-51.
- Bergman, B. and Klefsjö, B. (2003), *Quality from Customer Needs to Customer Satisfaction*, 2nd ed., Studentlitteratur, Lund.
- Bittner, K. and Spence, I. (2003), *Use Case Modeling*, Addison-Wesley, Boston, MA.

- Campbell, J.D. and Jardine, A.K.S. (2001), *Maintenance Excellence: Optimizing Equipment Life-Cycle Decisions*, Marcel Dekker, New York, NY.
- Candell, O. (2004), "Development of user information products for complex technical systems", Licentiate thesis, Luleå University of Technology, Luleå.
- Candell, O. and Karim, R. (2008), "eMaintenance – information driven maintenance and support", *Proceedings of the 18th International Conference on Flexible Automation and Intelligent Manufacturing (FAIM 2008)*, Skövde, 30 June.
- Candell, O. and Söderholm, P. (2006), "A customer and product support perspective of e-Maintenance", *Proceedings of the 19th International Congress of Condition Monitoring & Diagnostic Engineering Management (COMADEM)*, Luleå, 12-15 June, pp. 243-52.
- Coetzee, J. (1998), *Maintenance*, Maintenance Publishers, Hatfield.
- Erl, T. (2006), *Service-Oriented Architecture: Concepts, Technologies, and Design*, Pearson Education, Upper Saddle River, NJ.
- FMV (2005), *Technological Prognosis 2005*, Swedish Defence Material Administration, Stockholm (in Swedish).
- FMV (2006), *Standardiserad produktdata kapar kostnader*, Nyheter & Press, available at: www.fmv.se (accessed 6 April 2006) (in Swedish).
- FMV (2008), *Internal Documents*, Swedish Defence Materiel Administration, Stockholm.
- Grönroos, C. (2007), *Service Management and Marketing*, Wiley, Chichester.
- Gummesson, E. (2002), "Relationship marketing and new economy: it's time for de-programming", *Journal to Services Marketing*, Vol. 16 No. 7, pp. 585-9.
- Han, T. and Yang, B.-S. (2006), "Development of an e-maintenance system integrating advanced techniques", *Journal of Computers in Industry*, Vol. 57 No. 6, pp. 569-80.
- Haseloff, S. (2005), "Context awareness in information logistics", doctoral thesis, Elektrotechnik und Informatik der Technischen Universität Berlin, Berlin.
- Hawkins, F. (2006), "Condition monitoring in defence: the challenges ahead", *International Journal of COMADEM*, Vol. 9 No. 1, pp. 2-8.
- Heuwinkel, K., Deiters, W., Königsmann, T. and Löffler, T. (2003), "Information logistics and wearable computing", *Proceedings of the 23rd International Conference on Distributed Computing Systems, 19-22 May*, pp. 283-8.
- Holmgren, M. (2005), "Maintenance-related losses at the Swedish Rail", *Journal of Quality in Maintenance Engineering*, Vol. 11 No. 1, pp. 5-18.
- Holmgren, M. (2006), "Maintenance-related incidents and accidents: aspects of hazard identification", doctoral thesis, Division of Operation and Maintenance Engineering, Luleå University of Technology, Luleå.
- Holmgren, M. and Söderholm, P. (2008), "A process approach to maintenance-related hazard identification", *International Journal of COMADEM*, Vol. 11 No. 1, pp. 36-46.
- IBM (2008), "Nyheter: Utvecklingen av Försvarsmakten fortsätter", IBM, available at: www.ibm.com/news/se/sv/2007/05/02/n070172x67472a49.html (accessed 29 September 2008) (in Swedish).
- IEC (2004), *60300 (3-14): Dependability Management – Part 3-14: Application Guide – Maintenance and Maintenance Support*, International Electrotechnical Commission, Geneva.
- ISO/IEC (2008), *15288: Systems and Software Engineering – System Life Cycle Processes*, International Organization for Standardization and International Electro-Technical Commission, Geneva.
- Iung, B. and Crespo Marquez, A. (2006), "Editorial: special issue on eMaintenance", *Journal of Computers in Industry*, Vol. 57 No. 6, pp. 473-606.

- 
- Jacobson, I. (1992), *Object-Oriented Software Engineering: A Use Case Driven Approach*, ACM Press, New York, NY.
- Juran, J.M. (1992), *Juran on Quality by Design*, The Free Press, New York, NY.
- Kans, M. (2008), "On the utilisation of information technology for the management of profitable maintenance", doctoral thesis, Växjö University, Växjö.
- Karim, R., Kajko-Mattsson, M. and Söderholm, P. (2008a), "Exploiting SOA within eMaintenance", *Proceedings of the 30th International Conference on Software Engineering (ICSE), the 2nd International Workshop on Systems Development in SOA Environments, Leipzig, 10 May*.
- Karim, R., Kajko-Mattsson, M., Söderholm, P., Candell, O., Tyrberg, T., Öhlund, H. and Johansson, J. (2008b), "Positioning embedded software maintenance within industrial maintenance", *Proceedings of the 24th IEEE International Conference on Software Maintenance (ICSM), Beijing, 28 September*.
- Kletz, T. (1994), *What Went Wrong? Case Histories of Process Plant Disasters*, Gulf Publishing, Houston, TX.
- Koc, M. and Lee, J. (2001), "A system framework for next-generation e-Maintenance systems", *Proceedings of the 2nd International Symposium on Environmentally Conscious Design and Inverse Manufacturing, Tokyo, 11-15 December*.
- Kotonya, G. and Sommerville, I. (1998), *Requirements Engineering: Processes and Techniques*, Wiley, Chichester.
- Kumar, R. and Kumar, U. (2004), "A conceptual framework for the development of a service delivery strategy for industrial systems and products", *Journal of Business & Industrial Marketing*, Vol. 19 No. 5, pp. 310-9.
- Kumar, R., Markeset, T. and Kumar, U. (2004), "Maintenance of machinery: negotiating service contracts in business-to-business marketing", *International Journal of Service Industry Management*, Vol. 15 No. 4, pp. 400-13.
- Lee, J., Ni, J., Djurdjanovic, D., Qiu, H. and Liao, H. (2006), "Intelligent prognostics tools and e-maintenance", *Journal of Computers in Industry*, Vol. 57 No. 6, pp. 476-89.
- Levrat, E., Iunga, B. and Crespo Marquez, A. (2008), "E-maintenance: review and conceptual framework", *Production Planning & Control*, Vol. 19 No. 4, pp. 408-29.
- Liyanaage, J.P. and Kumar, U. (2003), "Towards a value-based view on operations and maintenance performance management", *Journal of Quality in Maintenance Engineering*, Vol. 9 No. 4, pp. 333-50.
- Markeset, T. (2003), "Dimensioning of product support: issues, challenges and opportunities", doctoral thesis, Hogskolan i Stavanger, Stavanger.
- Markeset, T. and Kumar, U. (2003), "Design and development of product support and maintenance concepts for industrial systems", *Journal of Quality in Maintenance Engineering*, Vol. 9 No. 4, pp. 376-92.
- Mizuno, S. (1988), *Management for Quality Improvement: The Seven New QC Tools*, Productivity Press, Cambridge, MA.
- Muller, A., Marquez, A.C. and Iung, B. (2008), "On the concept of eMaintenance: review and current research", *Journal of Reliability Engineering & System Safety*, Vol. 93 No. 8, pp. 1165-87.
- Newcomer, E. (2002), *Understanding Web Services*, Pearson Education, Indianapolis, IN.
- OASIS (2006), Organization for the Advancement of Structured Information Standards, available at: [www.oasis-open.org/committees/tc\\_home.php?wg\\_abbrev=plcs#overview](http://www.oasis-open.org/committees/tc_home.php?wg_abbrev=plcs#overview) (accessed 6 April 2006).

- OASIS (2008), "SOA", Organization for Advanced Standards for Information Society, available at: [www.oasis-open.org/](http://www.oasis-open.org/) (accessed 18 August 2008).
- Ollila, A. and Malmipuro, M. (1999), "Maintenance has a role in quality", *TQM Magazine*, Vol. 11 No. 1, pp. 17-21.
- Parida, A. and Kumar, U. (2004), "Managing information is key to maintenance effectiveness", *Proceedings of the Intelligent Maintenance Systems (IMS) 2004 International Conference, Arles, 15-17 July*.
- Parida, A., Phanse, K. and Kumar, U. (2004), "An integrated approach to design and development of e-maintenance system", *Proceedings of VETOMAC-3 and ACSIM-2004, New-Delhi, 6-9 December*, pp. 1141-7.
- Pulier, E. and Taylor, H. (2006), *Understanding Enterprise SOA*, Manning Publication Co., Greenwich, CT.
- Rasmussen, J., Mark Pejtersen, A. and Goodstein, L.P. (1994), *Cognitive Systems Engineering*, Wiley, New York, NY.
- Sharp, H., Finkelstein, A. and Galal, G. (1999), "Stakeholder identification in the requirements engineering process", *Proceedings of the 10th International Workshop on Database & and Expert Systems Applications, Florence, 1-3 September*, pp. 387-91.
- Shaw, M. and Garland, D. (1996), *Software Architecture: Perspective on Emerging Discipline*, Prentice-Hall, Upper Saddle River, NJ.
- Söderholm, P. (2005), "Maintenance and continuous improvement of complex systems: linking stakeholder requirements to the use of built-in test systems", doctoral thesis, Luleå University of Technology, Luleå.
- Söderholm, P. (2006), "A requirements management approach supporting integrated health management system design", *International Journal of COMADEM*, Vol. 9 No. 2, pp. 2-13.
- Söderholm, P. (2007), "A system view of the no fault found (NFF) phenomenon", *Reliability Engineering & System Safety*, Vol. 92 No. 1, pp. 1-14.
- Söderholm, P., Holmgren, M. and Klefsjö, B. (2007), "A process view of maintenance and its stakeholders", *Journal of Quality in Maintenance Engineering*, Vol. 13 No. 1, pp. 19-32.
- Sommerville, I. and Sawyer, P. (1997), *Requirements Engineering: A Good Practice Guide*, Wiley, Chichester.
- Sowa, J.F. and Zachman, J.A. (1992), "Extending and formalizing the framework for information systems architecture", *IBM Systems Journal*, Vol. 31 No. 3, pp. 590-616.
- SwAF (2008), Swedish Air Force Norrbotten Wing (F21), available at: [www.mil.se/en/Organisation/The-Swedish-Air-Force/](http://www.mil.se/en/Organisation/The-Swedish-Air-Force/) (accessed 18 October 2008).
- Tsang, A. (2002), "Strategic dimension of maintenance management", *Journal of Quality in Maintenance Engineering*, Vol. 8 No. 1, pp. 07-39.
- Yin, R.K. (2003), *Case Study Research: Design and Methods*, 3rd ed., Sage, Thousand Oaks, CA.
- Zeithaml, V.A., Parasuraman, A. and Berry, L.L. (1990), *Delivering Quality Service: Balancing Customer Perceptions and Expectations*, The Free Press, New York, NY.

#### Corresponding author

Ramin Karim can be contacted at: [ramin.karim@ltu.se](mailto:ramin.karim@ltu.se)

---

To purchase reprints of this article please e-mail: [reprints@emeraldinsight.com](mailto:reprints@emeraldinsight.com)  
 Or visit our web site for further details: [www.emeraldinsight.com/reprints](http://www.emeraldinsight.com/reprints)

## PAPER III

### **eMaintenance and Information Logistics: Aspects of Content Format**

Karim, R., **Candell, O.**, and Söderholm, P. (2009). eMaintenance and Information Logistics:Aspects of Content Format *Journal of Quality in Maintenance Engineering*, vol. 15, issue 3.







# METHODOLOGY AND THEORY

## E-maintenance and information logistics: aspects of content format

Ramin Karim

*Division of Operation & Maintenance Engineering,  
Luleå University of Technology, Luleå, Sweden*

Olov Candell

*Aircraft Services Division, Saab Aerotech, Linköping, Sweden*

Peter Söderholm

*Division of Operation & Maintenance Engineering,  
Luleå University of Technology, Luleå, Sweden*

### Abstract

**Purpose** – The purpose of this paper is to describe aspects of content sharing within e-maintenance, with a view to merging the two areas of maintenance and ICT in a content management perspective.

**Design/methodology/approach** – The approach is an explorative literature study covering aspects of ICT. The analysis is founded on theories related to maintenance and maintenance support. The conclusions of the study are corroborated by experiences from earlier software development and testing.

**Findings** – Most existing contributions to the e-maintenance debate seem to suffer from too wide a gap between data processing and knowledge management. This tendency can be due to too great a focus on data collection, without any clear identification of the stakeholders' requirements. Hence, a mature e-maintenance solution should focus on the enhancement of service-oriented information logistics based on content sharing for an output-based information strategy.

**Research limitations/implications** – This study focuses on the needs of content format and transformation content, which includes data format, data structures and data type for objects that are relevant for the maintenance process. Hence, further research could include aspects of infrastructure and service architecture, which are on a higher level of an e-maintenance solution.

**Practical implications** – The paper contributes with knowledge that supports decisions about content format in the development of an e-maintenance solution. This can in turn support a reduction of maintenance-related hazards through the improved use of ICT.

**Originality/value** – This paper describes the importance of content management within the e-maintenance approach. Hence, the paper has implications for both practitioners and researchers as described above.

**Keywords** Maintenance, Data analysis, Content management, Communication technologies

**Paper type** Research paper



---

## 1. Introduction

In today's society we are greatly dependent on the correct functioning of technical systems, a phenomenon which has made us vulnerable to disturbances. Over time, stakeholders' requirements of these systems' functions will change due to technical development, varying operational environments, changing laws and regulations, and so on. Hence, in order to maintain a high level of stakeholder satisfaction throughout the whole lifecycle of systems, those organisations responsible for the systems have to be responsive to changes in requirements through improved maintenance and system modification. Many complex technical systems are also critical ones, with stringent requirements of safety, dependability and costs throughout the system's lifecycle (Juran, 1992; Moubray, 1997; Sommerville and Sawyer, 1997; Herzwurm and Schockert, 2003; Liyanage and Kumar, 2003; Foley, 2001).

Maintenance is an approach that can be applied in order to ensure the safety and dependability of technical systems, and also to decrease the cost of operation throughout the system's life (Juran, 1992; Moubray, 1997; Sommerville and Sawyer, 1997; Herzwurm and Schockert, 2003; Liyanage and Kumar, 2003; Foley, 2001). Hence, different maintenance methodologies have been developed in order to manage the complexity and criticality of technical systems and their functions. Two examples of established maintenance methodologies are reliability-centred maintenance (RCM; Nowlan and Heap, 1978) and total productive maintenance (TPM) (Nakajima, 1988). Both these methodologies emphasise continuous improvement founded on fact-based decisions, and close cooperation between different stakeholders such as production, maintenance, and system design. Physical asset management may be seen as the highest level of maintenance management, and is achieved through a combination of RCM and TPM that, together with continuous improvement, aims at maintenance excellence (Campbell and Jardine, 2001). There is also an emerging view that maintenance not only reduces business risks, but also should be seen as a value-adding process in today's dynamic and competitive business environment (Liyanage and Kumar, 2003; Markeset and Kumar, 2003).

However, it should be noted that even though maintenance is intended to ensure system safety and dependability, there are numerous examples of cases where the maintenance of complex and critical systems has resulted in accidents with extensive losses. Some examples of maintenance-related accidents are the leak from a chemical plant at Bhopal (India, 1984), the Piper Alpha oil platform fire (North Sea, 1988), the disaster at the Phillips petrochemical plant in Texas (USA, 1989), the explosion and fires at the Texaco refinery at Milford Haven (UK, 1994), the chemical release and fire at the Associated Ocel Company Limited in Cheshire (UK, 1994), the derailment and collision at Ladbroke Grove (UK, 1999), and the derailment near Hatfield (UK, 2000). In addition to safety aspects, improper maintenance may also cause the system to deteriorate and thereby create quality deficiencies, such as delays and non-conforming products causing economical losses (Ollila and Malmipuro, 1999). Numerous studies also show that, paradoxically, between 50 and 70 per cent of all equipment fails prematurely after maintenance work has been performed (Nowlan and Heap, 1978; Moubray, 1997; Reason and Hobbs, 2003). One major cause of maintenance-related incidents and accidents is insufficient communication and information transfer within and between different phases and activities of the maintenance process (Holmgren, 2005, 2006; Holmgren and Söderholm, 2008). Insufficient information between different maintenance echelons is also one major cause of "no fault found" (NFF) events within industries such as the

automotive, train, trucking, and aerospace industries, where costs, safety, and dependability are affected negatively (Söderholm, 2005, 2007). One reason for the importance of proper information and communication within maintenance is the diversity of necessary content (e.g. both static and dynamic data regarding technical system, resources, and organisation) in order to perform different activities within the maintenance process. Hence, the approach taken to e-maintenance has the potential to improve the management of content necessary to perform activities related to the maintenance process and thereby improve dependability, safety, and life cycle costs of critical systems (Parida *et al.*, 2004; Parida and Kumar, 2004; Lee *et al.*, 2006).

Even though there are multiple views of what e-maintenance actually is, one common and vital part is the application of information and communication technology (ICT) to achieve effective information logistics within the maintenance area (see, for example, Koc and Lee, 2001; Tsang, 2002; Parida and Kumar, 2004; Jung and Crespo Marquez, 2006; Muller *et al.*, 2008). The aim of information logistics is to provide just-in-time (JIT) information to targeted users and to optimise the information supply process, i.e. making the right information available at the right time and at the right location (Heuwinkel *et al.*, 2003; Haseloff, 2005). Four fundamental aspects that need to be considered when establishing an information logistic solution are:

- (1) content management;
- (2) time management;
- (3) communication management; and
- (4) context management (Heuwinkel *et al.*, 2003; Haseloff, 2005).

However, existing efforts related to the structuring of e-maintenance often neglect content management and focus on the three other aspects – see, for example, Levrat *et al.* (2008) and Muller *et al.* (2008). This is an unsatisfactory situation since the other three aspects of information logistics can be considered as a support to content management since they aim at the provision of JIT content to targeted users and optimisation of the information supply process.

Hence, the purpose of this paper is to describe aspects of content sharing within an e-maintenance solution, in order to merge the two areas of maintenance and ICT in a content management perspective. This, it is believed, will contribute to a reduction of maintenance-related hazards caused by insufficient availability of information and communication in relation to the maintenance process.

## **2. Management of content for maintenance purposes**

There are a number of contributions that intend to support operation and maintenance management by the provision of artefacts, such as technologies, methodologies and tools. Some of these contributions that are relevant for e-maintenance from a content management perspective are summarised in Table I. The selection of contributions has been based on the following four criteria:

- (1) the artefact as such contributes in establishing an e-maintenance platform;
- (2) the artefact is based on, or intended to be used within, an ICT application;
- (3) the artefact can be used to provide an e-maintenance solution; and
- (4) the artefact can be used for sharing content relevant for the maintenance process.

Content management related contributions	Maintenance-specific	Focus area			Aspects of information logistics	Example of artefacts
		Application domain	Service domain	Technical publication		
AeroSpace and Defence Industries Association of Europe	Yes	Aerospace	Technical publication		Content	SI1000D
Business to Manufacturing Markup Language (BMMML)	No	Automation, manufacturing, maintenance, etc.	Generic		Content	IEC/ISO 62264
Center for Intelligent Maintenance Systems	Yes	Generic	Maintenance, e.g. proactive maintenance and support	Quality control and integrity	Content Context Time	Device-to-Business, Watchdog Agent
Document Management Applications (ISO/TC 171)	No	Generic	Generic		Communication Content Context Time	ISO 19005-1:2005, ISO 32000-1:2008, ISO 24517-1:2008 Dynamite platform
Dynamite	Yes	Generic	Health monitoring, prognostics, etc.		Content Context Time	
Industrial Automation Systems and Integration (ISO/TC 184)	No	Industrial automation	Generic		Communication Content Context Time	ISO 10303, ISO 115531, ISO 18435
Information and Documentation (ISO/TC 46)	No	Generic	Libraries, documentations, publishing, etc.		Content Context Time	ISO 15836:2003, ISO 2709:2008
Information Technology (ISO/JTC 1)	No	Information management	Generic		Content Context Time Communication	ISO/IEC 2382-17:1999, ISO/IEC 2382-4: 1999, ISO/IEC 15940: 2006 I, ISO/IEC 9075-1:2008; ISO/IEC 9075-14: 2008

(continued)

**Table I.**  
Examples of contributions related to content management relevant for e-maintenance

Table I.

Content management related contributions	Maintenance-specific	Focus area			Aspects of information logistics	Example of artefacts
		Application domain	Service domain	Information logistics		
ISA-95	Yes	Manufacturing	Enterprise and control systems	Content	Models and terminology, object models and attributes	
Machinery Information Management Open System Alliance (MIMOSA)	Yes	Manufacturing, fleet and facility environments	Operation and maintenance	Content Context Time	OSA-EAL, CRIS	
Materials, Equipments and Offshore Structure for Petroleum, Petrochemical and Natural Gas Industries (ISO/TC 67)	No	Petroleum and gas	Maintenance, etc.	Communications Content Context Time	ISO-14224	
Mechanical Vibration, Shock and Condition Monitoring (ISO/TC 108)	No	Generic	Mechanical vibration and shock	Content Context	ISO 13374	
Organisation for Advancement of Structural Information Standards (OASIS)	No	Generic	Generic	Context Time Communication	PLCS and PPS	
PROTEUS	Yes	Generic	Maintenance	Content	PROTEUS platform	
System for Mobile Maintenance (SMMART)	Yes	Generic	Remote information exchange, maintenance, logistic planning, etc.	Content Context Communication	SMMART platform	
Technologies and Techniques for New Maintenance Concepts (TATEM)	Yes	Aerospace	Health monitoring and management, aircraft operability assessment, process-oriented maintenance, etc.	Content Context Time Communication	TATEM platform	

(continued)

Content management related contributions	Maintenance-specific	Focus area			Aspects of information logistics	Example of artefacts
		Application domain	Service domain			
Technical Product Documentation (ISO/TC 10)	No	Technical products	Publications		Content Context Time	ISO 128-1:2003, IEC 82045-1:2001, IEC 82045-2: 2004, ISO 7573: 2008
Tele-maintenance platform (TELMA)	Yes	Manufacturing	Prognosis and aided decision-making		Content Context Context Time	TELMA platform
The Object Management Group (OMG)	No	Generic	Generic		Content Context Time Communication	UML, Corba
World Wide Web Consortium (W3C)	No	Generic	Generic		Content Context Time Communication	XML, XML Schema and RDF

Table I.

---

The first column of Table I, “Content management related contributions”, lists some of the contributions that are relevant for content management within e-maintenance, for example AeroSpace and Defence Industries Association of Europe (ASD). The second column, “Maintenance specific”, states whether a contribution is especially intended for maintenance purposes, or if it is a generic contribution that can be applied within maintenance. The third column, “Application domain”, highlights whether a contribution addresses a specific application domain (e.g. aerospace) or whether it is generic. The fourth column, “Service domain”, indicates which type of services within the application domain the contribution addresses (e.g. technical publications). The fifth column, “Aspects of Information Logistics”, indicates which of the four aspects within information logistics that is addressed by the contribution (i.e. management of content, time, communication and context). Finally, the sixth column, “Examples of artefacts”, provides examples of technologies, methodologies and tools related to a contribution (e.g. the standard S1000D). The remaining part of this section provides a more detailed description of the contributions listed in Table I.

### *2.1 Maintenance-specific contributions*

As shown in Table I, there are several contributions that address one or several phases within the maintenance process, i.e. management, support planning, preparation, execution, assessment or improvement (IEC, 2004). Some of these contributions focus mainly on the content aspect. One example is S1000D, which is provided by the ASD. S1000D is an international specification for the procurement and production of technical publications. The S1000D provides an ontology for the content of technical publications and also a content model, based on XML schema, through which a validity test of content can be performed. However, S1000D does not deal with technological aspects related to, for example, how content should be produced or delivered to a certain consumer (ASD, 2008).

Other examples are some artefacts provided by the Machinery Information Management Open System Alliance (MIMOSA), which is dedicated to the development of open information standards for operations and maintenance applications within manufacturing, fleet, and facility environments (MIMOSA, 2008a). One MIMOSA artefact is the specification Open System Architecture for Enterprise Application Integration (MIMOSA, 2005). Another artefact is MIMOSA’s Common Relational Information Schema (CRIS), which defines an information model that enables different systems to exchange information and data. Adopting CRIS does not necessarily mean that the system has to follow CRIS’s data model internally, but it must provide the ability to present and handle objects according to the specification. From the user’s point of view, utilisation of the OSA-EAI standard facilitates the integrations of asset management information and offers the user the flexibility to compose system components (MIMOSA, 2008b).

The Center for Intelligent Maintenance Systems (IMS) promotes cooperation between industry and academia, and provides support intended to enable products and systems to achieve and sustain near-zero breakdown performance. IMS-related contributions are aimed to support predictive and preventive maintenance instead of corrective maintenance. IMS focuses on the development of artefacts, such as: “Watchdog Agent Prognostics” for assessment and prediction of performance in a process, “Device-to-Business (D2B) Platform” for transformation of data and

---

information for the business sector, and “Decision Support Tools” (DTS) for simulation of rescheduling and reorganizing a process (IMS, 2008).

The PROTEUS project within Information Technology for European Advancement (TEA) provides an integrated platform that aims to support any broad e-maintenance strategy (Bangemann *et al.*, 2004, 2006). The PROTEUS project focused on the maintenance integration of existing maintenance-related applications. The objective was to improve the efficiency of industrial maintenance processes, utilising web and internet technologies to access expertise remotely. PROTEUS presents an integration model for its platform, which is based on the web services technology. The PROTEUS platform consists of logical tiers. One is the data tier, which represents the existing data sources of the existing application. Another one is the business tier, which represents a number of Business Logic Objects (BLO). BLOs reside in either the Application Core Adapter (ICA) or the Functional Core Adapter (FCA). ICA and FCA are software components with a given architecture and interface. ICA and FCA adapters communicate with applications in the Central Service Application (CSA).

Another maintenance-specific contribution in this area is ANSI/ISA-95, which is an international standard for the integration of enterprise and control systems. The ISA-95 standard is divided into three parts:

- (1) models and terminology;
- (2) object model attributes; and
- (3) models of manufacturing operations management.

The standard defines a model, which covers objects such as product, production, personnel, equipment, material, process segment, production schedule, and production performance. One part of the standard focuses on fulfilling the requirements of tracing and tracking (Fussell, 2005; ISA, 2008). It can be noted that ISA-95 is partly supported by technology providers, for example Microsoft and SAP.

Some other examples of maintenance-specific contributions that partly support the establishment of necessary information logistics are:

- the System for Mobile Maintenance (the SMMART project), with a focus on smart tags and wireless communication;
- the Tele-maintenance platform (TELMA), with a focus on prognosis and aided decision-making; and
- Technologies And Techniques for nEw Maintenance concepts (within the TATEM project), with a focus on monitoring technologies related to aviation.

These efforts focus mainly on the provision of ICT-based technologies that can be used for context management purposes within maintenance.

## 2.2 Generic contributions

As shown in Table I, there are several contributions that are not originally intended to support maintenance, but that can be applied for information logistic purposes within maintenance support.

An example of these contributions is the format language eXtensible Markup Language (XML), which is provided by World Wide Web Consortium (W3C). XML is a simple, flexible text format derived from the Standard Generalised Markup Language



(SGML), which has been an ISO standard since 1986 (ISO 8879). Originally designed to meet the challenges of large-scale electronic publishing, XML is also playing an increasingly important role in the exchange of a wide variety of data on the web and elsewhere (W3C, 2008a). XML is a format for storing and structuring content, but the XML family includes more than a format standard. W3C has developed several XML applications that make the XML format more usable. One of the applications is XML Schema (W3C, 2008b), which is an XML-based language that can be used to describe and define the data type and data structure. Another XML application is XSL (eXtensible Stylesheet Language), which consists of three parts:

- (1) XSLT, which is used for the transformation of XML content;
- (2) XSLFO, which is used for formatting of content; and
- (3) XPath, which is used to refer to a part of the content (W3C, 2008c).

XQuery is also a XML-based application that provides a mechanism to extract data from content. XQuery is capable of extracting information from different sources, such as structured and semi-structured documents, relational databases, and object repositories (W3C, 2008d).

There are also additional XML applications that are aimed at different usages. The e-maintenance infrastructure includes not only facilities for transforming data between systems, but also for transforming data from different systems to a human understandable format. In the world of XML, this is done by applying XSL to the content. However, one of the problems is that not all the browsers that are used on different types of desktops are full-featured and therefore cannot fully handle the combination of XML and XSL. In order to solve this problem, a format is needed that relies on existing standards, such as XML, but still can be widely used. Microformats is an upcoming format that is built on and reuses existing standards. Microformats contain not only the data, but also the semantics between data, which facilitate understanding of the content. Designed for humans first and machines second, micro-formats are a set of simple, open data formats built upon existing and widely adopted standards. However, microformats intend to solve simpler problems first by adapting to current behaviours and usage patterns (e.g. XHTML, blogging; see Microformats, 2006).

Since XML is generic and does not provide application-specific properties such as an ontology for a specific domain, other contributions have been provided in order to increase its usability. One of these is the Business to Manufacturing Markup Language (B2MML). B2MML is considered as an application of XML that uses XML Schema to describe context-specific namespaces including data structure and term definitions. The scope of B2MML schemas is based on the data model and attributes that are defined in ISA 95 (WBF, 2005). B2MML also describes a format for data exchange but not how the data is or can be used: neither the transaction handling nor the encapsulating is defined. B2MML offers schemas that are specialised for describing different categories of information object, for example common, equipment, maintenance, material, personnel, process segment, product definition, product capability, product performance and product schedule.

There are several Technical Committees (TCs) within the International Organization for Standardization (ISO) that contribute with artefacts that can be used within maintenance. One is the TC for Industrial Automation Systems and

---

Integration (ISO/TC 184). ISO/TC 184 develops standards for the representation of scientific, technical and industrial data; methods for assessing conformance to these standards; and also provides technical support to organizations seeking to deploy such standards in industry. The scope of the committee's contribution includes all the industrial data related to discrete products, such as geometric design and tolerance data, material and functional specifications, product differentiation and configuration, process design data, production data (including cost), product support and logistics, life cycle data, quality data, and disposal planning data. Data such as the relationship between enterprises or the relationship between components of a single enterprise for the purposes of supplier identification and personnel data to the extent of identification of approvals are also included. However, business planning data such as profit projections, cash flow, personnel data and organizational data are specifically excluded. Some of the standards provided by ISO/TC 184 are: ISO 10303, ISO 15531, ISO 15745, and ISO 18435 (ISO, 2007a).

The artefact ISO 10303, *Industrial Automation Systems and Integration – Product Data Representation and Exchange*, provides a representation of product information along with the necessary mechanisms and definitions to enable product data to be exchanged (ISO, 1994).

Another artefact, ISO 15531, *Industrial Automation Systems and Integration – Manufacturing Management Data Exchange (MANDATE)*, provides a representation of data relating to the management of the production process and the exchange and sharing of management data within or between companies. The standard identifies and covers three main categories of data relating to the management of manufacturing:

- (1) external exchanges (e.g. with suppliers);
- (2) the management of the resources used during the manufacturing processes; and
- (3) the management of the manufacturing flows within the plant and among the process stages.

In addition, the artefact ISO 15745, *Industrial Automation Systems and Integration*, is an open systems application integration framework that describes a basic framework for application interoperability. It provides a set of elements, integration models, and interaction profiles. The standard can be applied in areas such as process automation, manufacturing, material handling, and electronics assembly (ISO, 2003). ISO 15745 can be utilized to capture a real-world application's integration requirements and describe an integration model for different types of resources, such as equipment, material, and human. For these reasons, this standard can be useful for the maintenance process (e.g. in the preparation phase).

The artefact ISO 18435, *Industrial Automation Systems and Integration – Diagnostics, Capability Assessment, And Maintenance Applications Integration*, is (at the time of writing this article) an standard under development for industrial automation systems and integration. The purpose of the standard is to provide models, interfaces, and schemas that can be utilised by applications in order to improve interoperability. There are additional benefits to using these common models, interfaces, and schemas such as improved visibility of manufacturing management by providing information about current state of assets and also capability of the assets and minimising the disruption during the technology changes in systems. The models in ISO 18435 are defined and describe different use-scenarios, use-cases and roles

(actors that interact with the system), for instance management, operator and maintenance personnel (Carnahan *et al.*, 2005). This standard can be useful for the maintenance process, since it provides models, interfaces, and schemas that can be utilized by applications in order to improve interoperability.

Another TC within ISO is Information Technology (ISO/JTC 1). The scope of ongoing activities within this TC can be grouped in several areas, such as:

- telecommunications and information exchange between systems, software and systems engineering;
- cards and personal identification;
- programming languages;
- digitally recorded media for information interchange and storage;
- computer graphics;
- image processing and environmental data representation;
- interconnection of information technology equipment;
- security techniques;
- automatic identification and data capture techniques;
- data management and interchange;
- document description and processing languages;
- user interfaces; and
- information technology for learning, education and training (ISO, 2007b).

Since e-maintenance can be seen as an application area of ICT, it is necessary that a platform for e-maintenance involves both maintenance-related standards and technologies, but also the ones that are ICT-related.

Furthermore, ISO/TC 10, focuses on the standardisation and coordination of technical product documentation (TPD). TPD includes technical drawings, manually produced or computer based for technical purposes throughout the product life cycle, in order to facilitate document management and use, such as preparation, storage, retrieval, exchange, and reproduction (ISO, 2007c). Technical publications are an important resource ensuring effective and efficient activities, pinpointing different indenture levels of the technical system and different configurations throughout the lifecycle. The technical system's structure is important for the maintenance concept, which matches the indenture level of a technical system with a corresponding maintenance echelon of the organisation.

Contributions from ISO/TC 46, Information and Documentation, are related to libraries, documentation and information centres, publishing, archives, records management, museum documentation, indexing and abstracting services, and information science (ISO, 2007d). It is commonly accepted that there is a considerable amount of data and information that is generated within the phases of the maintenance process related to complex technical systems. In order to support the maintenance process, a high level of accessibility and availability is required, not only to current situation data, but also to historical information. Hence, this requirement should be considered and satisfied in an e-maintenance solution.

---

The ISO/TC 108, Mechanical Vibration, Shock and Condition Monitoring, addresses standardisation in the fields of mechanical vibration and shock and the effects of vibration and shock on humans, machines, vehicles (air, sea, land and rail) and stationary structures, and of the condition monitoring of machines and structures, using multidisciplinary approaches. Some of the areas of interest are:

- terminology and nomenclature in the fields of mechanical vibration, mechanical shock and condition monitoring;
- measurement, analysis and evaluation of vibration and shock active and passive control methods for vibration and shock;
- evaluation of the effects of vibration and shock on humans, machines, vehicles, stationary structures and sensitive equipment;
- vibration and shock measuring instrumentation;
- measurement methods, instrumentation, data acquisition, processing, presentation, analysis, diagnostics and prognostics, using all measurement variables required for the condition monitoring of machines; and
- training and certification of personnel in relevant areas (ISO, 2007e).

Contribution from this TC can be useful for the maintenance process, since it provides guidelines for software specifications related to data processing, communication, and presentation of machine condition monitoring and diagnostic information, which can be used to initiate and plan maintenance activities, especially when the strategy of condition-based maintenance (CBM) is applied.

ISO/TC 171, Document Management Applications, focuses on standardisation of quality control and integrity maintenance of documents, which can be presented in micrographic or electronic form. The scope of the TC's contributions includes:

- processes involving capture, indexing, storage, retrieval, distribution and communication, presentation, migration, exchange, preservation and disposal;
- input/output quality of micrographic or electronic documents;
- implementation, inspection and quality control procedures for storage, use and preservation of documents, including supportive metadata;
- applications involving workflow (process management) in an enterprise and on the internet;
- maintenance of quality and integrity during information exchange between systems;
- procedures and processes supporting legal admissibility and/or integrity and security; and
- management of related audit trail information (ISO, 2007f).

ISO/TC 67, Materials, Equipment and Offshore Structures for Petroleum, Petrochemical and Natural Gas Industries, focuses on standardisation of the materials, equipment and offshore structures used in the drilling, production, transport by pipelines and processing of liquid and gaseous hydrocarbons within application domains in the petroleum, petrochemical and natural gas industries (ISO, 2007g). One of the standards provided by this committee is ISO 14224, *Petroleum, Petrochemical and Natural Gas Industries* –

*Collection and Exchange of Reliability and Maintenance Data for Equipment* (ISO, 2006). The aim of the standard is to provide a basis for the collection of reliability and maintenance data in a standard format for equipment in all facilities and operations within the petroleum, natural gas and petrochemical industries during the operational life cycle of equipment. It describes data-collection principles and associated terms and definitions that can be useful for communicating operational experience. The failure modes defined in ISO 14224:2006 can be used as a reliability thesaurus for various quantitative as well as qualitative applications. ISO 14224:2006 also describes data quality control and assurance practices to provide guidance for the user (ISO, 2006). Hence, this standard may be useful for e-maintenance solutions within the petroleum, petrochemical and natural gas industries, since it focuses on data requirements for the type of data and data format for exchange of reliability and maintenance data.

Another example of an organisation that provides artefacts useful within maintenance is the Organization for the Advancement of Structured Information Standards (OASIS). Examples of standards developed by OASIS are *Production Planning and Scheduling (PPS)* and *Product Life Cycle Support (PLCS)*. PPS provides common object models and corresponding XML schemas for production planning and scheduling software which can communicate with each other in order to establish collaborative planning and scheduling intra and/or inter enterprises in manufacturing industries. The goal of the standard is to make a simple and extensible specification for real-time communications among various software applications that need information relevant to production planning or production scheduling (OASIS, 2006b). This may be valuable when dealing with systems and/or resources that are geographically distributed and thus may be a necessary cornerstone of the maintenance process. PLCS provides Data EXchange Specifications (DEXS) and a supporting infrastructure based on the International Standard ISO 10303-239:2005(E) *Industrial Automation Systems and Integration – Product Data representation and Exchange Part 239: Application Protocol: Product Life Cycle Support*. The purpose of PLCS is to establish structured data exchange and sharing to support complex engineered assets throughout their total life cycle (OASIS, 2006a). This is vital when dealing with complex and critical technical systems with a long useful life, for example modern combat aircraft with a life length of 25-30 years.

### **Discussion and conclusions**

One of the main objectives of e-maintenance is to enhance and support the maintenance process by establishing a content sharing process based on ICT that provides the right information at the right time, of the right quality, to the right actor. This content sharing process includes activities such as data collection, data filtering, data aggregation, data analysis, data distribution, and data visualisation.

One of the main issues that brings complexity to the process of information sharing is that the underlying data that need to be shared are produced within different processes, such as the business, operation, modification and maintenance processes. Each of the processes involved may utilise a number of different technologies implemented in a complex ICT environment. These heterogeneous ICT environments put new requirements on the process of content sharing.

One of the major requirements is the content format issue, which means that a sharable content must be packaged in a format that is not proprietary and can be managed by every involved part of the process. Another requirement is the structure of

---

the content, which means that a sharable content must be structured in accordance with a known, accepted and committed content model that describes the structure, semantics, and validity of the content. Hence, the question of the content format and content model is one of the major issues that needs to be considered when establishing an e-maintenance solution.

Fortunately, there are multiple academic and industrial artefacts available that can be used to establish an e-maintenance solution. Hence, artefacts from MIMOSA, ISO, ISA-95, and OASIS have relevance for, and should be considered, in order to develop an e-maintenance solution that supports the overall business and maintenance processes. It should also be noted that even if the artefacts above have relevance for all the phases of the maintenance process, it does not mean that they overlap each other in all aspects. Hence, the relevance and applicability of each artefact should be assessed and determined for every specific business case.

Furthermore, XML seems to be a widely applied format for data packaging. One of the reasons for this is probably the flexibility of XML, which provides the ability to separate content from its content model and presentation. B2MML is one XML application that defines a number of XML schemas, based on the object models from the ISA-95 standard. B2MML defines attributes, elements, and data structure in a hierarchical XML-based manner. The schemas can be used to package information about different information objects and also as an interface between different processes and activities within a process. Another XML-based application that offers term definitions and data structure is MIMOSA's OSA-EAI. There are also other standards and initiatives that provide object models and data structures mostly based on XML, such as OASIS's PLCS and PPS, which address the different part of the operation and maintenance processes.

It seems as if current information exchange standards are mostly developed and adapted for use in system-to-system interaction. However, the decision-making process requires a high human intervention, especially within maintenance, which sooner or later comes down to maintenance execution performed by technicians. This requires standards for information transforming in a system-to-human interaction, which is partly provided by XML-based microformats.

This paper covers mainly content, which is one of the essential aspects of information logistics. This aspect not only deals with the format, structure and ontology related to the content, but it also highly affects the other aspects of information logistics, which are time, communication and context. These aspects provide scope for further research related to infrastructure and service architecture within e-maintenance.

## References

- ASD (2008), "S1000D – International specification for technical publications: utilizing a common source database", AeroSpace and Defence Industries Association of Europe, ASD and Ministries of Defence of the Member Countries of ASD, No. 4.
- Bangemann, T., Reboul, D., Szymanski, J., Thomesse, J.-P. and Zerhouni, N. (2004), *Proceedings of the Intelligent Maintenance Systems (IMS) 2004 International Conference, Arles, 15-17 July*, PROTEUS – an integration platform for distributed maintenance systems.
- Bangemann, T., Rebeuf, X., Reboul, D., Schulze, A., Szymanski, J., Thomesse, J.-P., Thron, M. and Zerhouni, N. (2006), "PROTEUS – creating distributed maintenance systems through an integration platform", *Journal of Computers in Industry*, Vol. 57 No. 6, pp. 539-51.

- Campbell, J.D. and Jardine, A.K.S. (2001), *Maintenance Excellence: Optimizing Equipment Life-Cycle Decisions*, Marcel Dekker, New York, NY.
- Carnahan, D., Chung, D., delaHostria, E. and Hoover, C. (2005), "Integration of production, diagnostics, capability assessment, and maintenance information using ISO 18435", Technical Papers of the ISA No. 459, Instrumentation, Systems, and Automation Society, Research Triangle Park, NC, pp. 718-29.
- Foley, K. (2001), *Meta Management: A Stakeholder/Quality Management Approach to Whole-of-Enterprise Management*, Standards Australia, Sydney.
- Fussell, E. (2005), "ISA-95 inside: walking the talk from manufacturing to business systems", *InTech*, Vol. 52 No. 1, pp. 37-9.
- Haseloff, S. (2005), "Context awareness in information logistics", doctoral thesis, Elektrotechnik und Informatik der Technischen Universität Berlin, Berlin.
- Herzwurm, G. and Schockert, S. (2003), "The leading edge in QFD for software and electronic business", *International Journal of Quality & Reliability Management*, Vol. 20 No. 1, pp. 36-55.
- Heuwinkel, K., Deiters, W., Königsmann, T. and Löffler, T. (2003), "Information logistics and wearable computing", *Proceedings of the 23rd International Conference on Distributed Computing Systems, Providence, RI, 19-22 May*, pp. 283-8.
- Holmgren, M. (2005), "Maintenance-related losses at the Swedish Rail", *Journal of Quality in Maintenance Engineering*, Vol. 11 No. 1, pp. 5-18.
- Holmgren, M. (2006), "Maintenance-related incidents and accidents: aspects of hazard identification", doctoral thesis, Luleå University of Technology, Luleå.
- Holmgren, M. and Söderholm, P. (2008), "A process approach to maintenance-related hazard identification", *International Journal of COMADEM*, Vol. 11 No. 1, pp. 36-46.
- IEC (2004), *IEC 60300 (3-14): Dependability Management – Part 3-14: Application Guide - Maintenance and Maintenance Support*, International Electrotechnical Commission, Geneva.
- IMS (2008), Center for Intelligent Maintenance Systems, available at: [www.imscenter.net/](http://www.imscenter.net/) (8 October 2008).
- ISO (2003), *Industrial Automation Systems and Integration – Open Systems Application Integration Framework*, p. May, available at: [www.iso.org/iso/en/CatalogueDetailPage.CatalogueDetail?CSNUMBER=30418&ICS1=25&ICS2=40&ICS3=40](http://www.iso.org/iso/en/CatalogueDetailPage.CatalogueDetail?CSNUMBER=30418&ICS1=25&ICS2=40&ICS3=40) (accessed 9 May 2006).
- ISO (1994), *ISO-10303: Industrial Automation Systems and Integration – Product Data Representation and Exchange*, available at: [www.iso.org](http://www.iso.org) (accessed 2 April 2006).
- ISO (2006), *Petroleum, Petrochemical and Natural Gas Industries – Collection and Exchange of Reliability and Maintenance Data for Equipment*, available at: [www.iso.org/iso/en/CatalogueDetailPage.CatalogueDetail?CSNUMBER=36979&ICS1=75&ICS2=180&ICS3=1](http://www.iso.org/iso/en/CatalogueDetailPage.CatalogueDetail?CSNUMBER=36979&ICS1=75&ICS2=180&ICS3=1) (18 January 2007).
- ISO (2007a), "ISO Technical Committee (TC) 184 – Industrial Automation Systems and Integration", available at: [www.tc184-sc4.org/About\\_TC184-SC4/About\\_SC4\\_Organization/](http://www.tc184-sc4.org/About_TC184-SC4/About_SC4_Organization/) (accessed 8 February 2007).
- ISO (2007b), "ISO Technical Committee (TC) 1 – Information Technology", available at: [www.iso.org/iso/en/CatalogueListPage.CatalogueList?COMMID=1&scopelist=PROGRAMME](http://www.iso.org/iso/en/CatalogueListPage.CatalogueList?COMMID=1&scopelist=PROGRAMME) (accessed 8 February 2007).

- 
- ISO (2007c), "ISO Technical Committee (TC) 10 – Technical Product Documentation", available at: [www.iso.org/iso/en/stdsdevelopment/tc/tclist/TechnicalCommitteeDetailPage.TechnicalCommitteeDetail?COMMID=443](http://www.iso.org/iso/en/stdsdevelopment/tc/tclist/TechnicalCommitteeDetailPage.TechnicalCommitteeDetail?COMMID=443) (accessed 8 February 2007).
- ISO (2007d), "ISO Technical Committee (TC) 46 – Information and Documentation", available at: [www.iso.org/iso/en/stdsdevelopment/tc/tclist/TechnicalCommitteeStandardsListPage.TechnicalCommitteeStandardsList?COMMID=1757&INCLUDEESC=YES](http://www.iso.org/iso/en/stdsdevelopment/tc/tclist/TechnicalCommitteeStandardsListPage.TechnicalCommitteeStandardsList?COMMID=1757&INCLUDEESC=YES) (accessed 8 February 2008).
- ISO (2007e), "ISO Technical Committee (TC) 108 – Mechanical Vibration, Shock and Condition Monitoring", available at: [www.iso.org/iso/en/stdsdevelopment/tc/tclist/TechnicalCommitteeDetailPage.TechnicalCommitteeDetail?COMMID=3005](http://www.iso.org/iso/en/stdsdevelopment/tc/tclist/TechnicalCommitteeDetailPage.TechnicalCommitteeDetail?COMMID=3005) (accessed 18 February 2007).
- ISO (2007f), "ISO Technical Committee (TC) 4 – Document Management Applications", available at: [www.iso.org/iso/en/stdsdevelopment/tc/tclist/TechnicalCommitteeDetailPage.TechnicalCommitteeDetail?COMMID=4053](http://www.iso.org/iso/en/stdsdevelopment/tc/tclist/TechnicalCommitteeDetailPage.TechnicalCommitteeDetail?COMMID=4053) (accessed 8 February 2007).
- ISO (2007g), "ISO Technical Committee (TC) 67 – Materials, Equipment and Offshore Structures for Petroleum, Petrochemical and Natural Gas Industries", International Organisation for Standardisation, available at: [www.iso.org/iso/en/stdsdevelopment/tc/tclist/ Technical CommitteeDetailPage.TechnicalCommitteeDetail?COMMID=2113&scopelist=](http://www.iso.org/iso/en/stdsdevelopment/tc/tclist/TechnicalCommitteeDetailPage.TechnicalCommitteeDetail?COMMID=2113&scopelist=) (accessed 28 January 2007).
- Iung, B. and Crespo Marquez, A.A. (2006), "Editorial: special issue on eMaintenance", *Journal of Computers in Industry*, Vol. 57 No. 6, pp. 473-606.
- Juran, J.M. (1992), *Juran on Quality by Design*, The Free Press, New York, NY.
- Koc, M. and Lee, J. (2001), "A system framework for next-generation e-maintenance systems", *Proceedings of the 2nd International Symposium on Environmentally Conscious Design and Inverse Manufacturing, Tokyo, 11-15 December*.
- Lee, J., Ni, J., Djurdjanovic, D., Qiu, H. and Liao, H. (2006), "Intelligent prognostics tools and e-maintenance", *Journal of Computers in Industry*, Vol. 57 No. 6, pp. 476-89.
- Levrat, E., Iunga, B. and Crespo Marquez, A. (2008), "e-Maintenance: review and conceptual framework", *Production Planning & Control*, Vol. 19 No. 4, pp. 408-29.
- Liyanage, J.P. and Kumar, U. (2003), "Towards a value-based view on operations and maintenance performance management", *Journal of Quality in Maintenance Engineering*, Vol. 9 No. 4, pp. 333-50.
- Markeset, T. and Kumar, U. (2003), "Design and development of product support and maintenance concepts for industrial systems", *Journal of Quality in Maintenance Engineering*, Vol. 9 No. 4, pp. 376-92.
- Microformats (2006), Home page, available at: <http://microformats.org> (accessed 11 April 2006).
- MIMOSA (2005), *Open System Architecture for Enterprise Application Integration (OSA-EAI)*, Machinery Information Management Open System Alliance.
- MIMOSA (2008a), "Machinery Information Management Open System Alliance", available at [www.mimosa.org](http://www.mimosa.org) (accessed 18 July 2008).
- MIMOSA (2008b), "Common relational information schema", available at: [www.mimosa.org](http://www.mimosa.org) (accessed 18 March 2008).
- Moubray, J. (1997), *Reliability-Centred Maintenance*, Butterworth Heinemann, Oxford.
- Muller, A., Marquez, A.C. and Iung, B. (2008), "On the concept of e-maintenance: review and current research", *Journal of Reliability Engineering and System Safety*, Vol. 93 No. 8, pp. 1165-87.



- Nakajima, S. (1988), *Introduction to TPM: Total Productive Maintenance (Preventative Maintenance Series)*, Productivity Press, Cambridge, MA.
- Nowlan, F.S. and Heap, H.F. (1978), *Reliability Centred Maintenance*, Dolby Access Press, Los Altos, CA.
- OASIS (2006a), "OASIS Product Life Cycle Support (PLCS) TC", available at: [www.oasis-open.org/committees/tc\\_home.php?wg\\_abbrev=plcs](http://www.oasis-open.org/committees/tc_home.php?wg_abbrev=plcs) (accessed 4 April 2006).
- OASIS (2006b), "Organization for the Advancement of Structured Information Standards", available at [www.oasis-open.org/home/index.php](http://www.oasis-open.org/home/index.php) (accessed 4 April 2006).
- Ollila, A. and Malmipuro, M. (1999), "Maintenance has a role in quality", *The TQM Magazine*, Vol. 11 No. 1, pp. 17-21.
- Parida, A. and Kumar, U. (2004), "Managing information is key to maintenance effectiveness", Proceedings of the Intelligent Maintenance Systems (IMS) 2004 International Conference, Arles, 15-17 July.
- Parida, A., Phanse, K. and Kumar, U. (2004), "An integrated approach to design and development of e-maintenance system", *Proceedings of VETOMAC-3 and ACSIM-2004, New-Delhi, 6-9 December*, pp. 1141-7.
- Reason, J. and Hobbs, A. (2003), *Managing Maintenance Error: A Practical Guide*, Ashgate, Aldershot.
- Söderholm, P. (2005), "Maintenance and continuous improvement of complex systems, linking stakeholder requirements to the use of built-in test systems", doctoral thesis, Luleå University of Technology, Luleå.
- Söderholm, P. (2007), "A system view of the no fault found (NFF) phenomenon", *Reliability Engineering & System Safety*, Vol. 92 No. 1, pp. 1-14.
- Sommerville, I. and Sawyer, P. (1997), *Requirements Engineering – A Good Practice Guide*, Wiley, Chichester.
- Tsang, A. (2002), "Strategic dimension of maintenance management", *Journal of Quality in Maintenance Engineering*, Vol. 8 No. 1, pp. 07-39.
- W3C (2008a), "Extensible Markup Language (XML)", available at: [www.w3.org/XML](http://www.w3.org/XML) (accessed 18 October 2008).
- W3C (2008b), "The XML Schema", available at: [www.w3.org/xml/schema](http://www.w3.org/xml/schema) (accessed 19 March 2008).
- W3C (2008c), "XML Syntax for XQuery 1.0 (XQueryX)", available at: [www.w3.org/TR/xqueryx/](http://www.w3.org/TR/xqueryx/) (accessed 21 March 2008).
- W3C (2008d), "The Extensible Stylesheet Language Family (XSL)", available at: [www.w3.org/Style/XSL/](http://www.w3.org/Style/XSL/) (accessed 19 March 2008).
- WBF (2005), "Business to Manufacturing Markup Language (B2MML)", available at: [www.wbf.org/displaycommon.cfm?an=1&subarticlenbr=45](http://www.wbf.org/displaycommon.cfm?an=1&subarticlenbr=45) (accessed 16 March 2006).
- Wikipedia (2008), ISA-95 members' documents, available at: <http://en.wikipedia.org> (accessed 18 October 2008).

**Corresponding author**

Ramin Karim can be contacted at: [ramin.karim@ltu.se](mailto:ramin.karim@ltu.se)

---

To purchase reprints of this article please e-mail: [reprints@emeraldinsight.com](mailto:reprints@emeraldinsight.com)  
Or visit our web site for further details: [www.emeraldinsight.com/reprints](http://www.emeraldinsight.com/reprints)



## PAPER IV

### Design of Experiments and Simulation for Identification of Significant eMaintenance Services

Söderholm, P., Karim, R. and **Candell, O.** (2008). *Design of Experiments and Simulation for Identification of Significant eMaintenance Services* (**Submitted to a journal**).



## Design of Experiment and Simulation for Identification of Significant eMaintenance Services

PETER SÖDERHOLM<sup>1</sup>, RAMIN KARIM<sup>2</sup>, OLOV CANDELL<sup>3</sup>

<sup>1</sup>*Expert and Development Unit, Banverket,  
SE-971 02, Luleå, Sweden*

<sup>2</sup>*Division of Operation and Maintenance Engineering, Luleå University of Technology,  
SE-971 87 Luleå, Sweden*

<sup>3</sup>*Division of Aircraft Services, Saab Aerotech,  
SE-581 88 Linköping, Sweden*

*(Received on October 21, 2009)*

**Abstract:** The purpose of this paper is to present a methodology and a supporting toolbox that identify information-based maintenance support services using an evaluation of the services' impacts on the effectiveness of complex technical systems. A hypothetical aircraft and its support system are simulated in SIMLOX. The variables included in the model, as well as their expected effects on critical measures of system-effectiveness, were identified through interviews and studies of documents and the literature. The simulations have been planned and analysed according to established Design of Experiment (DoE) principles supported by MATLAB. Microsoft Access and Microsoft Visual Studio .NET has been used to integrate SIMLOX and MATLAB. The outcome of the study was scrutinised by both practitioners and statisticians. The methodology and its toolbox are useful for those involved in simulation work or the development of information services that support maintenance activities. The proposed systematic methodology, along with its supporting toolbox, identifies information-based services that are currently lacking when applying a Service-Oriented Architecture (SOA) approach during design and are considered valuable in identifying information-based maintenance support services within an eMaintenance solution.

**Keywords:** *Maintenance support, information services, eMaintenance, complex technical systems, simulation, Design of Experiment (DoE), Service-Oriented Architecture (SOA).*

### 1 Introduction

Maintenance may be seen as a process that monitors a technical system's ability to deliver services, and records problems for analysis, takes corrective, adaptive, perfective, and preventive actions, and confirms restored capability [1, 2, 3, 4]. To be efficient and effective, the maintenance process should be horizontally aligned with the operation and modification processes, and it should be vertically aligned with the requirements of external stakeholders [3, 5]. Simultaneously, actors within the maintenance process require support to perform their activities as intended. This maintenance support consists of resources such as documentation, personnel, support equipment, materials, spare parts, facilities, information, and information systems [4]. Hence, one critical characteristic of successful maintenance support is the ability to provide the right information to the right information consumer and producer with the right quality at the right time [6, 7, 8]. This

---

\*Corresponding author's email: [ramin.karim@ltu.se](mailto:ramin.karim@ltu.se)

desirable situation can be achieved through appropriate information logistics. These logistics aim to provide just-in-time information to targeted users and to optimize the information supply process, i.e., make the correct information available at the right time and at the correct location [9, 10]. Due to this challenge and increasing information needs, the development of Information & Communication Technology (ICT) in the early 2000s contributed to the emergence of eMaintenance, which today is a common term in the maintenance-related literature [11, 12].

Although there are multiple views on what eMaintenance actually is, one common and vital part is the application of ICT to achieve effective information logistics within the maintenance area [7, 11, 13, 14]. Hence, establishing a dynamic and effective eMaintenance solution requires appropriate software architecture. Many efforts related to software architecture within eMaintenance are complementary and contribute to achieving service-oriented information logistics within the maintenance area [15, 16, 17, 18]. However, there have been only limited efforts related to identifying the necessary information services that support maintenance activities using a Service-Oriented Architecture (SAO) approach.

The purpose of this paper is to describe a methodology and a supporting toolbox that identify information-based maintenance support services using an evaluation of the services' impacts on the effectiveness of complex technical systems.

The structure of the remaining part of this paper is as follows. First, the proposed methodology and its supporting toolbox are described. After that, the developed simulation model is outlined. The DoE principles that have been applied within the methodology are then described. Thereafter, a presentation of the analysis and results are provided. The paper ends with some conclusions and a discussion.

## **2 Developed methodology and toolbox**

The developed toolbox provides support to each of the five phases included in the proposed methodology (Figure 1). The toolbox includes a number of software tools that have two different purposes, i.e., simulation and analysis or integration. The two software tools SIMLOX and MATLAB are used for simulation and analysis purposes, respectively, while Microsoft Visual Studio .NET (MsVS) and Microsoft Access (MsAC) are mainly used to integrate the two other tools. See [19] for more detailed information about the developed toolbox and simulation model, as well as applied data and obtained results.

The main purpose of Phase I is to establish the maintenance concept, i.e., a description of the interrelationship between the indenture levels and the maintenance echelons [20]. Hence, two major artefacts need to be described during this phase: first, a description of the technical system's indenture levels, i.e., the subdivision of an item from the point of view of a maintenance action [20]; and second, a description of the maintenance echelons, i.e., the positions in an organization where specified maintenance actions are carried out [20]. Furthermore, detailed data on the system's inherent items need to be provided, e.g., reliability measures such as failure rate, Mean Time To Failure (MTTF), and Mean Time Between Failures (MTBF). These descriptions and related data constitute the input to SIMLOX, which is the software tool used to simulate logistics and operations. In this phase, the input of data to SIMLOX is conducted manually.

The purpose of Phase II is to provide a design matrix that is based on DoE principles. One of the first steps in the experimental design is to select the control variables, response variables, nuisance factors, and constant factors [21, 22]. These

factors and variables need to be documented in a proper format. In this work, MS Excel was used for this purpose.

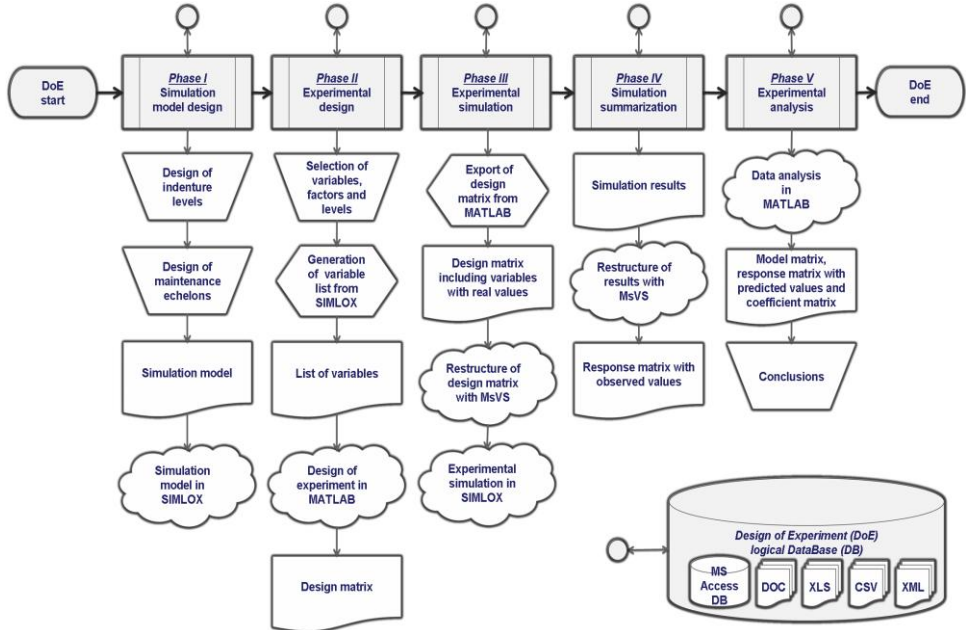

**Figure 1:** Illustration of the steps of the proposed methodology and its supporting toolbox

The next step is to generate a list that contains the control variables with their values from SIMLOX. This step is performed with a developed component that uses the variable-list as input and retrieves its value from the SIMLOX database. The component is also capable of applying the different levels (e.g., low and high levels for a two-level factorial design) of each control variable. The generated list is stored in an MsAC database. However, this list needs to be restructured and reformatted before it can be used in MATLAB, the software tool used for both design and analysis of the experiments. This restructuring is performed by an integrating component that has been developed in MsVS. The next step is conducted in MATLAB through developed components that restructure the list of control variables into a design matrix, **D**, that consists of a set of runs.

The purpose of Phase III is to execute simulations according to the design matrix, which is exported from Phase II, restructured into a proper format, and imported into the SIMLOX database. Before each run, the value of all control variables is set to the value of the initial model defined in Phase I. Thereafter, the value of each control variable is set to the desired level for the current run, according to the design matrix, **D**. Finally, after each run, corresponding values of the response variables are stored in the SIMLOX database as a response matrix, **Y**.

The purpose of Phase IV is to compile and correlate the output values of the response variables recorded in the response matrix, **Y**, with corresponding runs in the design matrix, **D**. This is performed through an integrating component developed in MsVS that retrieves the results from the SIMLOX response matrix and joins them with the design matrix into a combined matrix, [**D Y**].

The purpose of Phase V is to analyse the simulations based on the combined matrix developed in the previous phase. This analysis is conducted using components for matrix algebra developed in MATLAB. The model matrix,  $\mathbf{X}$ , is achieved by including an initial column of 1's in the design matrix, i.e.,  $\mathbf{X} = [\mathbf{1} \ \mathbf{D}]$ . Hence, the regression model becomes  $\mathbf{Y} = \mathbf{XA} + \mathbf{e}$ , for  $n$  runs and  $k-1$  control variables, where  $\mathbf{A}$  is a matrix with the estimated regression coefficients and  $\mathbf{e}$  is a matrix with the sample residuals. Hence, the matrix for the predicted responses becomes:  $\hat{\mathbf{Y}} = \mathbf{XA}$ . The Ordinary Least Squares (OLS) coefficients of  $\mathbf{A}$  are obtained by solving  $\mathbf{A} = (\mathbf{X}'\mathbf{X})^{-1}\mathbf{X}'\mathbf{Y}$ . Using a combination of the last two expressions, it is possible to estimate the response values according to the following:  $\hat{\mathbf{Y}} = \mathbf{X}(\mathbf{X}'\mathbf{X})^{-1}\mathbf{X}'\mathbf{Y}$ . Then, the estimated regression coefficients and response variables act as inputs to the continued analysis, e.g., by the use of normal probability plots, as described later in this paper. See [23] for a further discussion about regressions in matrix form.

### 3 Developed simulation model

The development of a simulation model is included in the first phase of the proposed methodology. However, it should be noted that much of this planning is highly influenced by the second phase of the methodology, which means that Phase I and Phase II must be performed iteratively.

In SIMLOX, the effectiveness results are collected from the actual event sequences generated in the simulation. A basic assumption in the model is that system maintenance is largely performed by replacement of faulty parts, both repairable and those discarded at failure. The model represents in detail the support organisation that supplies working spare parts to the systems and handles the transport and repair of faulty repairable units. The support organisation can be viewed as a set of different stocks and repair facilities (maintenance echelon) that are linked to each other by transport facilities. At each such support node, the resources needed for repairs and for other kinds of maintenance are deployed. [24]

In the present study, four different types of variables and factors were considered, i.e., control variables, held-constant factors, nuisance factors, and response variables. Control variables are measurable, controllable, and thought to be (very) influential. Held-constant factors are controlled. Nuisance factors are uncontrolled factors (which either cannot be controlled or are allowed to vary). In this study, possible control variables, held constant factors, and nuisance factors were chosen from the input parameters available in SIMLOX. See [21] for a further discussion about these variables, factors, and their implications for the design of experiments.

The response variables in this study are based on the output parameters available in SIMLOX. These output parameters are mainly different kinds of Measures of Effectiveness (MoE) related to the operation of the technical system, and they are divided into a number of groups. In all, 56 response variables were included in the simulations; see [24] for a complete list of the response variables available in SIMLOX.

In this study, two different levels are considered for the control variables: one level with a low degree of ICT implementation and the other with a high degree of ICT implementation. The control variables can be classified into two groups: maintainability performance and maintenance support performance. On a more detailed level, SIMLOX input parameters that are considered to be affected by the degree of ICT application are used as control variables in the study. The number of control variables depends on the complexity of the simulation model, e.g., the



complexity of the technical system and its support environment. However, considering the available input parameters in SIMLOX, 54 were classified as potential control variables.

It should be noted that both the control and response variables available in SIMLOX can be connected to multiple indenture levels of the technical system, multiple maintenance echelons of the support system, or both. Hence, the actual number of control and response variables included in the experimental design highly depends on the particular problem and the required complexity of the simulation model.

Since an eMaintenance solution is not considered to affect the reliability performance of a technical system to any large degree, parameters related to the reliability performance are treated as held-constant factors. However, it should be noted that ICT that is added to the technical system will affect its reliability performance. Examples of such ICT are additional Built-in-Test Equipment (BITE) and equipment that transfers data and information both within the technical system and to receivers in the support system. There are also variables in SIMLOX that cannot be independently varied since they co-vary. These variables were not included as control variables and were classified as held constant factors.

Since the study is performed in a controlled simulation environment, no nuisance factors were considered. Hence, there was no need to apply any DoE approaches intended to address the impact from nuisance factors (e.g., randomization and blocking). Furthermore, the simulation context also means that there are no major practical restrictions to consider. However, the software tools chosen for simulation (SIMLOX), experimental design and analysis (MATLAB), and integration (MsAC and MsVS) put some restrictions on both the types and number of factors and variables that can be included in the experiment. There are also some other practical considerations related to time and available computer resources, and these are discussed at the end of this paper.

Based on the purpose of the study and the discussion presented above, a model of an aircraft and its support system, with 52 control variables (including multiple indenture levels of the aircraft), was constructed in the first phase of the proposed methodology; see Figure 2 for an illustration of this model.

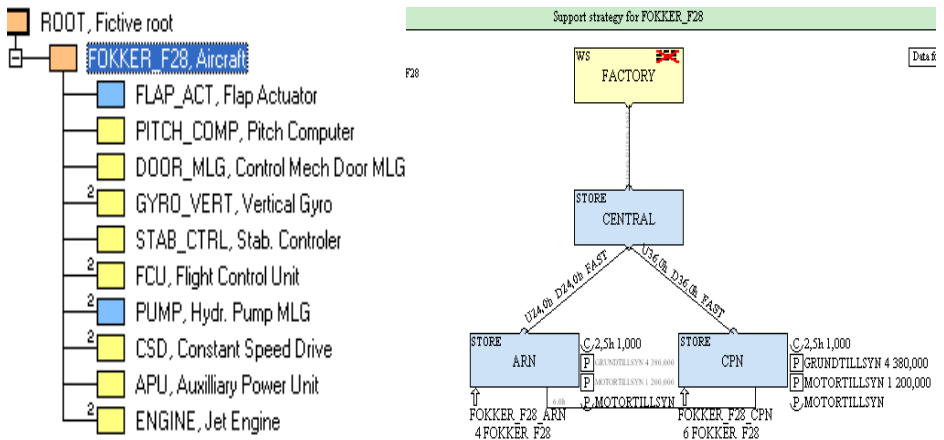

Figure 2: Illustration of the modelled technical system (left side) and its support system (right side)

#### 4 Applied Design of Experiment (DoE) Principles

This section corresponds to Phases II and V of the proposed methodology (see Figure 1). In order to efficiently and systematically explore the large number of variables included in the model of a complex technical system and its support environment, DoE principles are judged to be an attractive approach. For example, [25] used DoE principles for robust multi-facilities tactical planning, which is similar to the support environment. However, they did not consider any technical system, focussed on the cost-robustness on demand variability, and considered a fairly small number of variables. There have also been some efforts related to DoE in simulation-based acquisition, which is concerned with similar problems and solution domains as those in this study (e.g., [26]). Another effort is the focus on appropriate methodological support for computer-aided planning and design of manufacturing simulation experiments [27]. This covers another application area, but it has a similar methodological approach as the one proposed in this paper. However, no publication focuses on the application of DoE principles to identify information valuable for maintenance support.

The planning of the experiment followed the seven step methodology described by [21]. The first three steps of their methodology dealt with the planning that precedes the design of the experiment, made in accordance with the guidelines given by [21]. This work is included in the second phase of the methodology proposed here.

Since the number of control variables in a simulation tends to be quite large, the sequential use of fractional factorial design was considered to be a very useful approach. The reason is that this approach often leads to great economy and efficiency in experimentation [22]. For example, it is possible to construct resolution III designs for investigating up to  $k = N - 1$  variables in only  $N$  runs, where  $N$  is a multiple of 4. This fractional factorial design is said to be saturated. Hence, with a saturated fractional factorial design, it is possible to study seven variables in only eight runs. If there is a second fraction in which the signs for all the variables are reversed, a full fold over (or reflection) is achieved. This full fold over breaks the alias links between the main effects and the two-factor interactions. Hence, this combined design can be used to estimate the main effects apart from any two-factor interaction (i.e., resolution IV) in only 16 runs. See [22, 28] for further discussions about fold over designs. A summary of some useful fractional factorial designs with resolution III from the  $2^{k-p}$  system, related combined designs with resolution IV, and a corresponding number of runs are given in Table 1.

If a combined design that uses full fold over is applied in the simulation, it is possible to estimate 63 variables in only 128 runs (see Table 1). In contrast, if an ordinary  $2^k$  factorial design had been applied,  $2^{63} \approx 9.22 \cdot 10^{18}$  runs would have been necessary. Hence, by selecting a full fold over, the combined design is based on an ordinary  $2^6$  design (64 runs), which is expended with a reflection of itself (where the signs of all included control variables are reversed) and results in a total of 128 runs.

**Table 1:** Useful fractional factorial designs from the  $2^{k-p}$  system. The numbers in the cells are the number of runs in the experiment

Design type	Number of control variables in the experiment						
	3	7	15	31	63	127	255
Resolution III fraction (single)	4	8	16	32	64	128	256
Resolution IV fraction (combined)	8	16	32	64	128	256	512

This selection seemed to be an appropriate balance for the present study, since the two closest alternatives with a combined design, as described above, would enable an estimation of 31 or 127 control variables, respectively (see Table 1). The alternative with 31 variables was judged to be too limited to fulfil the purpose of the study. On the other hand, the alternative with 127 variables, which would require 256 runs, was one possible alternative. However, the work efforts required to manage this large number of control variables was not considered since this study was intended as a screening design. It should be noted that there are several approaches, in addition to the one discussed above, to select alternative fold over plans for two-level fractional factorial designs (e.g., [29, 30]).

Considering the restrictions discussed above and the control variables that were judged to be worthy of investigating, a model of the technical system and its support system, which included 52 control variables, was constructed in Phase I of the proposed methodology. Hence, a full two-level factorial design (e.g., [31]) turned out to be unrealistic since it would require  $2^{52} \approx 4.5 \cdot 10^{15}$  runs. However, since the study was of an explorative nature, it was considered appropriate to use a two step approach. The first step was a combined design based on a full fold over with 63 control variables, as discussed above. This combined design gives information about which first order effects are significant and ensures that there is no aliasing between first order effects and second order interactions. The purpose of this first step was to screen and identify significant control variables. As a second step, an ordinary two-level full factorial design based on the significant control variables identified in the first step was applied. This means that the second stage can estimate first order effects, first order interactions, and second order effects (e.g., [22, 28]).

For analysis purposes (Phase V of the proposed methodology), there are multiple alternatives available to identify the control variables that have a significant effect on the different response variables (e.g., [22, 28, 31]). However, the developed simulation model does not include any distributions for the different included variables. Hence, using replications would not give any error that could be used to estimate significant effects. However, it should be noted that the simulation tool SIMLOX enables the inclusion of distributions for some variables, which is a valuable topic for further research. One approach to analyse an unreplicated factorial is to assume that certain high-order interactions are negligible and combine their mean squares to estimate the error. This is an appeal to the sparsity of effects principle [22], which states that most systems are dominated by some of the main effects and low-order interactions, so most high-order interactions are negligible. However, in some cases, high-order interactions do occur, and the use of a mean square obtained by pooling high-order interactions becomes inappropriate [22]. Another example of when it is impossible to pool high-order interactions is when a combined design is used, as in this study. The reason is that every effect is represented by a control variable. On the other hand, since the developed model includes only 52 control variables, there are

$63 - 52 = 11$  effects that can be used to estimate the error. However, this is considered to be too few effects. Hence, it may instead be possible to examine a normal probability plot of the estimated effects. The effects that are negligible are normally distributed, with a mean of zero and a variance  $\sigma^2$ , meaning that they will tend to fall along a straight line on the normal probability plot. However, significant effects will have nonzero means and will not lie along a straight line. The preliminary model will thus contain the effects that are apparently nonzero (by examination of the normal probability plot), whereas the apparently negligible effects are combined as an estimate of the error. See [22] for further discussion on the use of normal probability plots in the analysis of designed experiments.

## 5 Analysis and Results

Phases IV and V of the proposed methodology are related to the compilation and analysis of results, respectively. The analysis of the results from the first screening experimental design showed that five response variables could be predicted with a satisfactory degree of error, i.e., a Residual Sum of Squares (RSS) that was less than 15. These five response variables were risk of shortage (ROS), risk of shortage with time tolerance (ROST), probability of no backorders (PNB), number of systems in active repair (NSYRP), and number of systems in active preventive maintenance (NSYPM).

These response variables can be divided into two groups, one related to stock performance (ROS, ROST and PNB) and the other related to the maintenance of specific aircraft systems (NSYPM and NSYRP). Hence, ROS, ROST, and PNB are related to each other, as are NSYRP and NSYPM (SYSTECON, 2005). For example, both NSYRP and NSYPM are important parts of the number of unavailable systems (NSYUA). The other part of NSYUA is systems that are waiting for maintenance. The major difference between NSYRP and NSYPM is whether the active maintenance action is corrective or preventive. Hence, both responses include the systems that are in active corrective or preventive maintenance, respectively. Maintenance actions that are passively waiting for replacement items or resources are not included in NSYUA. Maintenance actions carried out at remote locations further back in the support organization are included, but systems in transport are not. Maintenance of non-critical failures is included once they have become active. NSYUA includes all systems at the unit that are in maintenance (active or waiting) and are therefore not available for new missions. Systems having only non-critical failures or damages are still available for new missions as long as active maintenance has not started. Therefore, these systems are not included in NSYUA. See [24] for a more detailed description of these response variables.

If one assumes that the five response variables described above can be predicted using multiple regression analysis, the effects that deviate from a straight line in their respective normal probability plots may be considered as significant. The normal probability plots for ROS/ROST, PNB, NSYRP, and NSYPM are given in Figure 3.

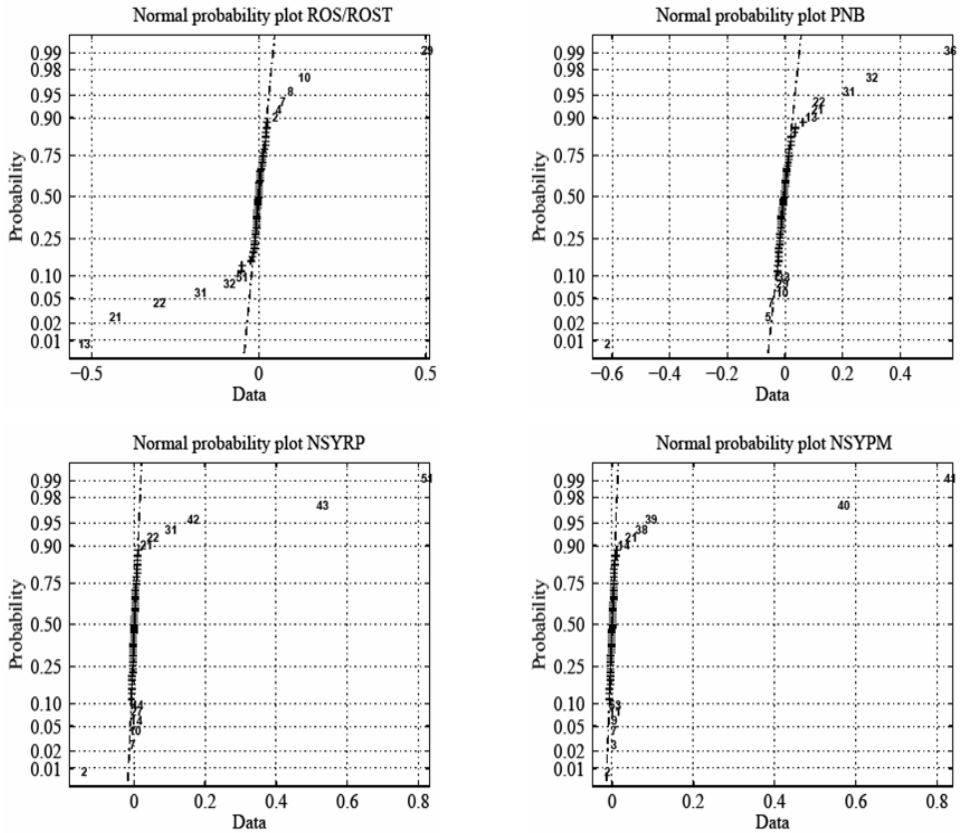

**Figure 3:** Normal probability plots for the coefficients of five responses

An examination of the normal probability plot for the response number of systems in active repair (NSYRP) reveals that 12 effects deviate from a straight line and can be judged as significant; see the lower left plot in Figure 3. Furthermore, based on the sparsity principle, it may be reasonable to preliminarily assume that these effects are caused by the control variables and not by any of their interactions. For example, the two highest effects (51 and 43) are related to No Fault Found (NFF) events in two aircraft systems, i.e., a hydraulic pump and the Auxiliary Power Unit (APU), respectively. These effects are positive, which means that a change from a low to a high level of NFF events will increase NSYRP. This change corresponds to an inverse change in the degree of ICT-application. Hence, this preliminary analysis indicates that the provision of information services that support the corrective maintenance actions at the two maintenance echelons will lead to the greatest improvements of NSYRP.

An examination of the normal probability plot for the number of systems in active preventive maintenance (NSYPM) response indicates that 12 effects may be significant; see lower right plot of Figure 3. Furthermore, it may initially be reasonable to assume that the two highest effects (41 and 40) are caused by corresponding control variables and not aliasing interactions. However, a closer examination shows that the largest effect (41) probably is not caused by the control variable turnaround time needed for corrective maintenance (in this case, item

replacement) at the ARN maintenance echelon. The reason for this is that NSYMP is related to preventive and not corrective maintenance. Hence, in this case it is more probable that effect 41 represents some third or higher order interaction. However, the next largest effect (40) is probably caused by the turnaround time needed to carry out preventive inspections of the engine at the CPN maintenance echelon. Both these effects are positive, which means that a change from a low to a high level will increase the number of systems in active preventive maintenance (NSYPM). This change corresponds to the inverse change in the degree of ICT-application. Hence, it is reasonable to assume that the provision of information services that support these two maintenance actions at the corresponding maintenance echelons will contribute most to an improved NSYMP.

In the normal probability plots, it is also seen that effect number 2 is significant for all responses (Figure 3). For the system-related responses NSYRP and NSYMP, the effect is negative. In a similar manner as that described above, it is reasonable to tentatively assume that this effect is caused by the corresponding main factor, i.e., the lead time needed to reorder the flap actuator. This is a discardable item that is never repaired or sent for preventive maintenance. The stocks of discardable items are instead replenished by a reorder task. The lead time is the time from the order of a new item until the corresponding delivery arrives. Hence, a negative effect means that an increased lead time will decrease the number of items in active corrective and preventive maintenance. Considering the stock-related responses, the effect is positive for ROS/ROST, while it is negative for PNB. This means that an increased lead time will increase the risk of shortage (ROS/ROST) and reduce the probability of no backorders (PNB). Hence, if PNB is a critical measure of effectiveness, an information service that can reduce the lead time and thereby increase PNB would be beneficial to implement. The reason is that the lead time has the greatest effect on PNB. The effect of decreased lead time would also benefit other response variables, though not as much as PNB.

However, one result of this preliminary analysis is that there are too many significant control variables (28) to do a full two-level factorial design to simultaneously investigate the five response variables. The numbers of control variables can probably be reduced by a more careful examination of the normal probability plots for each response variable. Another possibility would be to reduce the number of response variables that are to be investigated further. The criteria for excluding a response variable could be that it is not of any major interest, or that it is quite obvious. The goal would be to have less than 20 control variables, since this would allow for a full two-level factorial design. A third alternative would be to split the second stage into multiple experimental designs, e.g., one design focusing on stock-related responses and another design focusing on system-related responses.

Hence, as a second step, two different designs were created. The first design included the three stock-related response variables (ROS, ROST, and PNB) and nine control variables, i.e.,  $2^9 = 512$  runs. However, it should be noted that ROS and ROST could be used interchangeably, since these two are affected by the same control variables to the same degree (Figure 3). The reason for this is that no time distributions were included in the simulation model, which means that ROS and ROST become the same. The other design included the two system-related response variables (NSYRP and NSYPM) and 15 control variables, i.e.,  $2^{15} = 32,768$  runs.

Due to technical obstacles, the experimental design for NSYRP and NSYMP was not possible to execute. Hence, for these two responses it was necessary to rely on the information that could be extracted from the first screening design in order to pinpoint

information services that could support maintenance activities, which has been briefly described in relation to Figure 3. Further work could look into possibly reducing the number of included control variables. However, it would be more interesting and useful to identify why the developed toolbox encountered problems with a full two-level factorial design with only 15 control variables and solve this limitation.

The normal probability plots for ROS/ROST and PNB, based on the results from the second design, are given in the upper half of Figure 4. By examining these plots in the same way as discussed in relation to Figure 3, it is possible to identify significant effects and related ICT-based information services that provide valuable support to maintenance activities. The plots of the predicted responses versus the true responses result in relatively straight lines (see lower half of Figure 4). This indicates that the response variables ROS/ROST and PNB can be predicted satisfactorily by using multiple regression models based on the identified significant factors. It should be noted that the numbering of effects differs from the one applied in the first screening design since the design matrices used in the two steps are different.

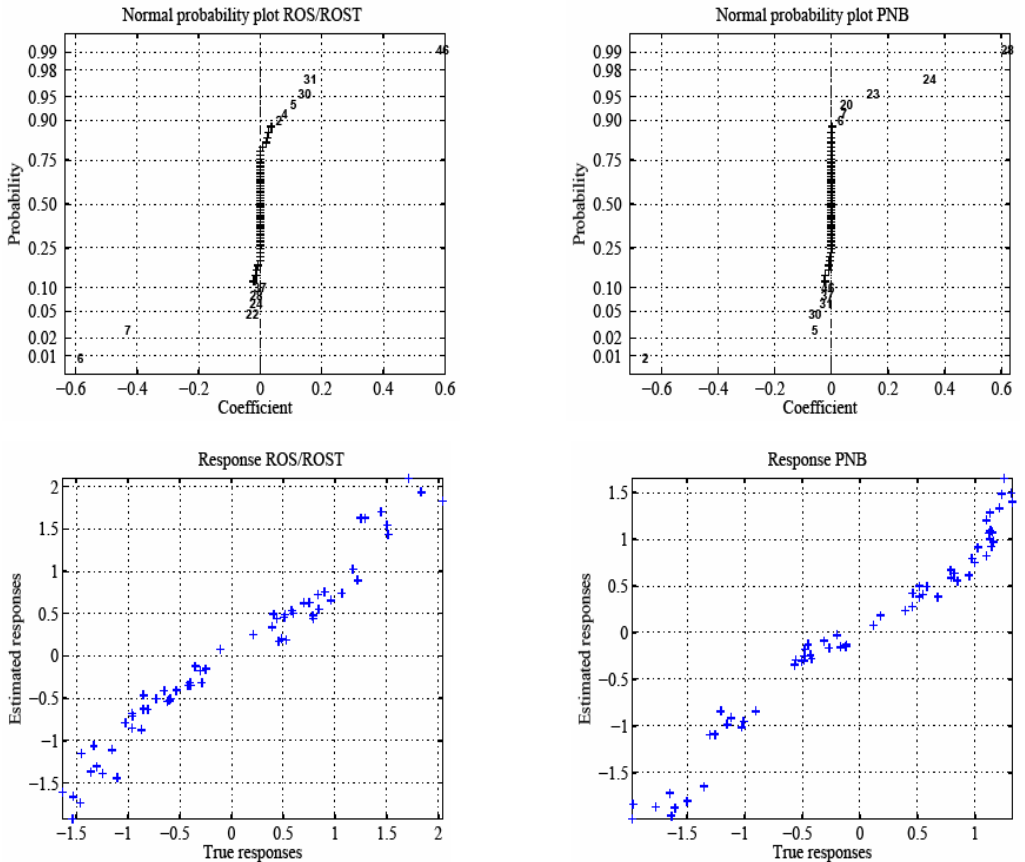

**Figure 4:** Normal probability plots (upper half) and response plots (lower half) for three stock-related response variables

## 6 Discussion and conclusions

To support the proposed methodology for the identification of information-based maintenance support services, four software tools (MATLAB, SIMLOX, MsAC, and MsVS) were adapted and integrated into a toolbox that facilitates a combination of simulation and Design of Experiment (DoE) principles. Hence, the methodology and its toolbox provide valuable support to those that want to combine these principles to identify information services that have significant impact on a support solution, e.g. as part of an eMaintenance solution.

In order to achieve the desired methodological support for the design and execution of experiments, a heterogeneous development environment was necessary. The reason was that the applied software tools, MATLAB and SIMLOX, do not provide an open generic interface that can be accessed from other environments, such as MsVS. Furthermore, MATLAB provides its own high level programming language that can be used within its environment, while SIMLOX lacks this feature. Hence, to provide a seamless workflow between these software tools, several different programming languages and development environments had to be utilized. However, one drawback with this approach is that it results in some overlaps that reduce the reusability of the developed components.

A large factorial design results in a large number of runs. In a simulation context, this requires resources such as process time, processor capacity, and memory. Furthermore, if the structure of the system, with respect to the number of included items, and its maintenance support are complex, the number of possible control variables and the time for each run increases. In order to perform the runs within a reasonable period of time, the inherent software components must be scalable, e.g., provide multi-threading for simultaneous execution and the ability to spread the execution onto several parallel processors and servers. These types of features are essential to providing the scalability that is required for the management of large experimental designs and especially replications. However, some of the selected software tools in the developed toolbox lack the capability to provide such a scalability feature, which resulted in a sequential model for the execution of runs. This might be one reason that the two-level full factorial design with 15 variables, i.e.,  $2^{15} = 32,768$  runs, was not possible to complete.

During the design, execution, and analysis of experimental designs in a simulation context, a large amount of data is created. These data need to be correlated to each other during the different phases of the proposed methodology. Hence, a proper mechanism to manage the data is needed, which can be achieved by a Relational DataBase Management System (RDBMS). In the compiled toolbox, MsAC was selected as the RDBMS. However, the performed study shows that MsAC lacks the capability to manage the large amount of data in the required amount of time. MsAC also lacks the capability to provide and manage the important scalability features mentioned earlier.

Further research could focus on the inclusion of distributions for the experimental factors and variables when appropriate. This is possible to do with the selected simulation tool. Including distributions for the control variables makes it meaningful to perform replications of runs, which enables an analysis of the control variables' effect on the responses' variations by using the  $\log(s^2)$  as a response. This possibility may be of interest where it is more important to reduce the variability than to reach specific response levels, or when it is of interest to perform a sensitivity analysis. The applied simulation tool is able to quickly perform many replications of each run



through Monte Carlo simulation. However, if the replications are based on the whole experimental plan, aspects of scalability and data management become critical since several software tools have to be integrated with each other. Another interesting possibility for further research is to use DoE principles to optimize the support system.

### Acknowledgements

We would like to acknowledge the financial support of the Swedish National Aeronautics Research Programme (Nationella flygtekniska forskningsprogrammet, NFFP), project eMaintenance 24-7 (NFFP4-S4401). We would also like to thank Saab Aerotech for acquainting us with their experiences and thus making this study possible. We are also grateful to Associate Professor Johan Carlson at the Division of System Technology at Luleå University of Technology for support with DoE work and MATLAB programming.

### References

- [1] Coetzee J. *Maintenance*, Maintenance Publishers 1998; Hatfield.
- [2] Campbell J.D., and A.K.S. Jardine. *Maintenance Excellence: Optimizing Equipment Life-Cycle Decisions*; New York: Marcel Dekker; 2001.
- [3] Söderholm P., M. Holmgren, and B. Klefsjö. *A process view of maintenance and its stakeholders*. Journal of Quality in Maintenance Engineering 2007; 13(1):19-32.
- [4] ISO/IEC. *15288: Systems Engineering - System Life Cycle Processes*. Geneva: International Organization for Standardization and International Electrotechnical Commission; 2008.
- [5] Liyanage J.P., and U. Kumar. *Towards a value-based view on operations and maintenance performance management*. Journal of Quality in Maintenance Engineering 2003; 9(4):333-350.
- [6] Parida A., and U. Kumar. *Managing Information is key to maintenance effectiveness*. Proceedings of the Intelligent Maintenance Systems (IMS) 2004 International Conference 2004; Jul 15-17; Arles, France.
- [7] Parida A., K. Phanse, and U. Kumar. *An integrated approach to design and development of e-maintenance system*. Proceedings of VETOMAC-3 and ACSIM-2004 2004; Dec 6-9, New-Delhi. p. 1141-1147.
- [8] Lee J., J. Ni, D. Djurdjanovic, H. Qiu, and H. Liao. *Intelligent prognostics tools and e-maintenance*. Journal of Computers in Industry 2006; 57(6):476-489.
- [9] Heuwinkel K., W. Deiters, T. Königsmann, and T. Löffler. *Information logistics and wearable computing*. Proceedings of the 23<sup>rd</sup> International Conference on Distributed Computing Systems 2003; May 19-22. p. 283-288.
- [10] Haseloff S. *Context Awareness in Information Logistics*. Berlin: Elektrotechnik und Informatik der Technischen Universität; 2005.
- [11] Muller A., A.C. Marquez, and B. Iung. *On the concept of eMaintenance: Review and current research*. Journal of Reliability Engineering and System Safety 2008; 93(8):1165-1187.
- [12] Levrat E., B. Iunga, and A. Crespo Marquez. *E-maintenance: review and conceptual framework*. Production Planning & Control 2008; 19(4):408-429.
- [13] Tsang A. *Strategic dimension of maintenance management*. Journal of Quality in Maintenance Engineering 2002; 8(1):7-39.
- [14] Iung B., and A. Crespo Marquez. *Editorial: Special Issue on eMaintenance*. Journal of Computers in Industry 2006; 57(6):473-606.
- [15] Bangemann T., D. Reboul, J. Szymanski, J-P Thomesse, and N. Zerhouni. (2004), PROTEUS: An Integration Platform for Distributed Maintenance Systems. Proceedings of the Intelligent Maintenance Systems (IMS) International Conference 2004; July 15-17; Arles, France.

- [16] Bangemann T., X. Rebeuf, D. Reboul, A. Schulze, J. Szymanski, J-P Thomesse, M. Thron, and N. Zerhouni. *PROTEUS: Creating distributed maintenance systems through an integration platform*. Journal of Computers in Industry 2006; 57(6):539–551.
- [17] Han T., and B.S. Yang. *Development of an e-maintenance system integrating advanced techniques*. Journal of Computers in Industry 2006; 57(6):569-580.
- [18] Kans M. *On the Utilisation of Information Technology for the Management of Profitable Maintenance*. Doctoral thesis; Växjö: Växjö University; 2008.
- [19] Karim R. *Material related to the Development of a Toolbox based on Design of Experiment (DoE) Principles*. Luleå University of Technology; 2008.
- [20] IEC. *60300 (3-14): Dependability management - Part 3-14: Application guide-Maintenance and maintenance support*. Geneva: International Electrotechnical Commission; 2004.
- [21] Coleman D.E., and D.C. Montgomery. *A Systematic approach to planning for a designed industrial experiment*. Technometrics 1993; 35(1):1-12.
- [22] Montgomery D.C. *Design and Analysis of Experiments*. New York: John Wiley and Sons; 2005.
- [23] Hamilton L.C. *Regression with Graphics: A Second Course in Applied Statistics*. California: Brooks/Cole; 1992.
- [24] SYSTECON. *Simlox User's Reference*. Stockholm: SYSTECON AB; 2005.
- [25] Genin P., S. Lamouri, and A. Thomas. *Multi-facilities tactical planning robustness with experimental design*. Production Planning & Control 2008; 19(2):171-182.
- [26] Mavris D.N., and O. Bandte. (1995). Economic uncertainty assessment using a combined Design of Experiments/Monte Carlo simulation approach with application to an HSCT. In Proceedings of 17<sup>th</sup> Annual Conference of the International Society of Parametric Analysts 1995; May 30 - June 2; San Diego, CA.
- [27] Özdemirel N.E., G.Y. Yurttas, and G. Köksal. *Computer-aided planning and design of manufacturing simulation experiments*. Simulation 1996; 67(3):171-191.
- [28] Carlson R. and J.E. Carlson. *Design and Optimization in Organic Synthesis: Second Enlarged and Revised Edition*. Amsterdam: Elsevier 2005.
- [29] Li W., and D.K.J. Lin. *Optimal foldover plans for two-level fractional factorial designs*. Technometrics 2003; 45(2):142-149.
- [30] Fang K.T., D.K.J. Lin, and H. Qin. *A note on optimal foldover design*. Statistics & Probability Letters 2003; 62(3):245-250.
- [31] Box G.E.P., W.G. Hunter, and J.S. Hunter. *Statistics for Experimenters*. New York: John Wiley and Sons; 1978.

**Peter Söderholm**, is risk manager at Banverket (the Swedish Rail Administration). He has been working in joint academic and industry projects related to dependability and risk since 2001, mainly within aviation and railway. Peter has a M.Sc. in mechanical engineering, a Licentiate of Engineering in quality technology, and a Ph.D. in operation and maintenance engineering. He is also active in the development of national and international standards related to dependability and risk. Peter has more than 40 peer reviewed scientific publications.

**Ramin Karim**, is Assistant Professor at Luleå University of Technology (LTU). He has a B.Sc. in Computer Science, and both a Licentiate of Engineering and a Ph.D. in Operation & Maintenance Engineering. He has worked within the Information & Communication Technology (ICT) area for 18 years, as architect, project manager, software designer, product owner, and developer. Karim is responsible for the research area eMaintenance at LTU, and has published more than 15 papers related to eMaintenance.

**Olov Candell**, has more than twenty years of experience working with support systems and operation and maintenance techniques in various positions in the defence industry, e.g. as radar engineer, technical writer, project manager, line manager, business developer and manager of technology development. In addition to a broad and long experience in the areas of support, operation and maintenance technologies, Olov has an academic researcher education (Licentiate of Engineering in quality technology) focused on the development of information products and services for operation and maintenance.

## PAPER V

### **Service-oriented information logistics as support to intelligent transport services**

**Candell, O.,** Karim, R., Söderholm, P. and Kumar , U. (2009). Service-oriented information logistics as support to intelligent transport services. The *16<sup>th</sup> World Congress and Exhibition on Intelligent Transport Systems and Services*, 21st-25th September 2009, Stockholm, Sweden.



# SERVICE-ORIENTED INFORMATION LOGISTICS AS SUPPORT TO INTELLIGENT TRANSPORT SERVICES

Olov Candell<sup>1</sup>, Ramin Karim<sup>2</sup>, Peter Söderholm<sup>2</sup>, and Uday Kumar<sup>2</sup>

<sup>1</sup>) Saab Aerotech  
Aircraft Services Division  
SE-581 88, Linköping, Sweden  
+46 13 18 17 39  
olov.candell@saabgroup.com

<sup>2</sup>) Luleå university of technology  
Luleå, SE-971 87, Sweden  
+46 920 49 23 44

[ramin.karim] [peter.soderholm] [uday.kumar] @ltu.se

## ABSTRACT

Today's society is dependent on an increasing volume of transportation services, which contributes to escalating requirements on economy, dependability, safety, and sustainability of applied transportation systems. When dealing with complex transportation systems with long life cycles, maintenance is fundamental to ensure these critical requirements. The increasing requirements and the technological development have also lead to the emerging approach of eMaintenance, which applies innovative Information & Communication Technology (ICT) to achieve effective information logistics for maintenance purposes. This paper describes the role and development of service-oriented eMaintenance solutions to enable intelligent transportation services and some related research efforts within railway and aviation.

## 1 INTRODUCTION

Today's society is dependent on an increasing volume of transportation of both goods and passengers. This leads to steadily increase in the need of transportation volumes, as well as in requirements on economy, dependability, safety, and sustainability of the transports. To fulfil these needs and requirements, different modes of transportation have to be integrated and both their systems-of-interest (i.e. infrastructure and vehicles), enabling-systems (e.g. traffic control systems, ticketing systems, tracking systems, and computerised maintenance management systems), and enabling services (e.g. information logistics, support, and maintenance) have to be streamlined and integrated to provide timely and effective transportation services.

One example of a national effort intended to achieve this desirable transformation of the transportation sector is the development in Sweden, where the integration of all modes of transportation are intended to be facilitated through the development of the Swedish Transport Agency. This agency is working to achieve good accessibility, high quality, secure and environmentally aware rail, air, sea and road transport. The agency has the overall responsibility for drawing up regulations and ensuring that authorities, companies, organisations and citizens abide by them. [1]

Another important contribution is the technological development. The adaptation of technological advances in the Swedish Armed Forces is one illustrative example of the impact of new technology, as described by the Swedish Defence Material Administration [2] in a prognosis of the coming 25 years. In the future, the Swedish Armed Forces are expected to be a more integrated part of the society that they are expected to protect, than they have been before.

Hence, in order to solve their tasks, the Armed Forces have to cooperate with other national and international authorities, organisations, and companies to a larger extent than before. Another aspect is that there exist many large and complex systems within the Armed Forces. In the future, these systems will be part of a much larger, complex, and dynamic system-of-systems. Simultaneously, individual systems are also becoming smaller (micro and nano scale), highly digitalised, sensor rich, and equipped with Information & Communication Technology (ICT). Another change is that unmanned systems (e.g. Unmanned Aerial Vehicle, UAV) will have an increasing role to play.

One example of a national technological effort in Sweden that reflects the scenario outlined above is the development of a network-based defence, which is coordinated with agencies for civil security (see e.g. [3, 4]). The origin of this project was the task of the Armed Forces to integrate all of its service branches (i.e. Army, Air Force and Navy), while it later expanded to the integration with the agencies for civil security (e.g. the National Rescue Services Board, the Swedish Coast Guard, and the National Police Authorities). This information infrastructure is a valuable complement to the Swedish Government's ambition to create common principles of electronic data exchange between all governmental agencies, which should cover the content taxonomy.

As outlined above, one important contribution to the desired transformation of the transport sector is the research, development and use of intelligent transport services and systems. In order to achieve intelligent transportation services, information logistics is one fundamental enabling service that can be realised through enabling systems based on new and innovative ICT. The main aim of information logistics is to provide just-in-time information to targeted users and optimization of the information supply process, i.e. making the right information available at the right time and at the right point of location [5, 6]. Information logistic services need to deal with: I) time management, which addresses 'when to deliver'; II) content management, which refers to 'what to deliver'; III) communication management, which refers to 'how to deliver'; and IV) context management, which addresses 'where and why to deliver' [5, 6].

When dealing with transportation systems that are complex and have long life cycles, one critical application of information logistics and ICT is for maintenance purposes, which often are referred to as eMaintenance. One view of eMaintenance is the integration of all necessary ICT-based tools for optimization of costs and improvements of productivity through utilization of Web services [7, 8]. This view can be considered as a system-oriented approach to eMaintenance, where Web services technology is used to facilitate integration of information sources that contain maintenance-relevant content.

There are also service-oriented approaches to eMaintenance that deal with information logistics and information services as support to maintenance through the adaptation of a Service-Oriented Architecture (SOA), see e.g. [9].

To achieve proper information logistic solutions, a combined approach that deals with both systems and services is required. However, most efforts seems emphasise the system part and somewhat miss the service part. This is highly unfortunate since the services are the reason that any system should exists. On the other hand, innovative systems may results in new and unknown services; cf. the Kano model and its inclusion of known and unknown requirements [10].

This paper describes the role and development of service-oriented eMaintenance solutions to enable intelligent transportation services and some related research efforts within railway and aviation.

## **2 INTELLIGENT TRANSPORT SERVICES AND SYSTEMS**

From a lifecycle perspective a system might be viewed as a system-of-interest or as an enabling-system. A system-of-interest is a system whose lifecycle is under consideration within a given context, while an enabling-system is a system that complements a system-of-interest during its lifecycle stages, but does not necessarily contribute directly to its function during operation [11]. Analogously, a service might from a lifecycle perspective also be categorised as a service-of-interest or as an enabling-service, since a service is a set of functions offered to a user by an organisation [12]. By this convention, transportation is a service-of-interest, while travelling booking is one example of an enabling-service.

When regarding transportation as a service-of-interest, the mode of transportation is secondary and depends upon the context of the service consumer, as illustrated in Figure 1. This context is affected by available resources (e.g. time and money), capabilities of the transportation systems (e.g. speed and accessibility) and state of the surrounding environment (e.g. accidents and weather conditions). One traditional use of travelling booking as an enabling service is the advance reservation of a trip through a travelling agent. In this case, the travelling agent provides some type of “intelligence” by combining information available from different sources in order to provide a transportation service that meets the requirements of the traveller. The booking service is normally provided before the trip is initiated, but can also be adapted to changing traveller requirement during the trip (as long as the changes occur during opening hours).

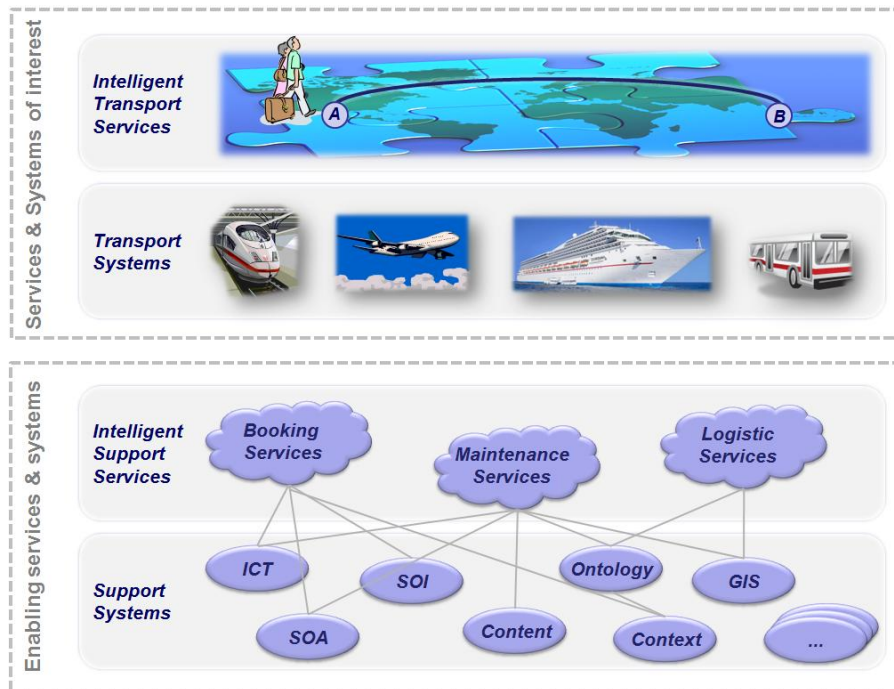

**Figure 1 - Relation between systems of interest and enabling systems within the context of intelligent transport systems**

Another category of enabling-services is maintenance-related, which can be used to provide the service consumer information related to maintenance and adapted to the consumer's current situation and needs. Maintenance-related information can be used to increase the effectiveness and efficiency of the transport services and system, but also to provide the consumer of the transport services situation-adapted information. For example, information about scheduled maintenance activities on an item within a transport system, e.g. vehicle and rail, can be used within the maintenance process to enable opportunistic maintenance in order to reduce the negative impact on current or planned transports as much as possible. Simultaneously, the same information can be correlated to spatial data in order to provide better decision-support for a route planning service aimed at the consumer of the transport service. Hence, the provision of information services can be considered as essential enabling-services that complement the transport services and contribute to increased satisfaction of the service consumer.

The two examples of enabling-services described above illustrates the contribution of human intelligence, which may be defined as a mental quality that consists of the abilities to learn from experience, adapt to new situations, understand and handle abstract concepts, and use knowledge to manipulate one's environment. Artificial Intelligence (AI), on the other hand, may be defined as the ability of a machine to perform tasks thought to require human intelligence, which is frequently applied to the development of systems endowed with the intellectual processes characteristic of humans, such as the ability to reason, discover meaning, generalise, or learn from past experience. See [13] for further descriptions of these definitions of intelligence.



Hence, intelligent transport services and systems should, among other things, be able to adapt to new situations. However, this ability requires information input that is received from enabling services and systems, which in turn also should be intelligent. The required intelligence will probably always be a combination of human and artificial intelligence, even though the latter part often is in focus since it is expected to increase in importance in the future.

One important feature of the required intelligence is the ability to make a stratification of service consumers according to their need to access information, their role, hardware and software costs, and security concerns. This stratification of consumers can be based on their network interaction and be distinguished in different dimensions, e.g. based on: the degree of required access (including both the number of participants in the operational function and the variety of data required); the security requirements; and the timeliness (or time criticality of the required information support). These criteria may be used to establish four basic types of network interaction, e.g. specialised interaction; ubiquitous interaction; secure interaction; and real-time interaction (see Figure 2 and [14]).

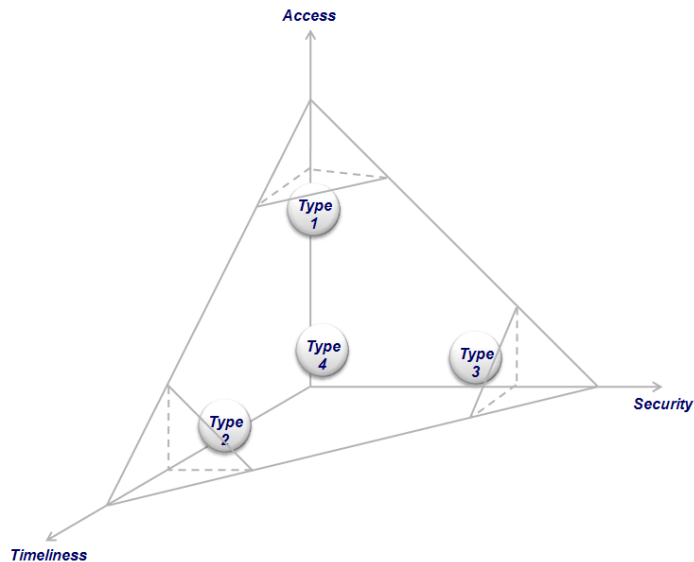

**Figure 2 – Service interaction dimensions and types, adapted from [14]**

Specialised interaction involves requirements that are not as extreme as for the other three types. The requirements for access to information vary with the role and its information context. As the level of access, timeliness, and security approaches zero, the need for any form of network disappears.

Ubiquitous interaction often affects a large numbers of organisations, e.g. as support to resource management activities and supply functions, along with certain transportations that requires an orchestration of several modes of transportation, e.g. long distance

travel. In general, the multiple participants in the supported travel require similar access to data and information on all aspects of the travel available on the federated network.

Secure interaction is related to roles that require that both activities and information are secure, which puts unique demands on the network for interactions among roles and the information exchanged to be secured both physically and electronically. Most services related civil security agencies involved in transportation require this kind of interaction, e.g. police and ambulance.

Real-time interaction is related to roles that require information support that is usually extremely time-sensitive, e.g. drivers of vehicles and traffic control personnel. Another example is the transportation of highly hazardous materials that require that very few participants have access to critical real-time data and are able to share that data among all involved roles, even when network connections and nodes have failed.

### **3 ENABLING SERVICES AND SYSTEMS**

In order to provide intelligent transport services there is a need of underlying enabling-services, e.g. maintenance, logistics and support.

The provision of maintenance services to various stakeholders, e.g. internal users and external customers, is highly dependent on enabling-services that ensure the fulfilment of defined requirements and thereby achieve customer satisfaction. These enabling-services aim at support to maintenance.

Maintenance support addresses all resources required to maintain a system, under a given maintenance concept and guided by a maintenance policy. The required resources include human resources, support equipment, materials and spare parts, maintenance facilities, documentation, information and maintenance information systems [15]. In this context, information management is essential in order to enable the provision of relevant, appropriate, complete, valid, and timely support in the form of information throughout the system's whole lifecycle [11]. Managing information relies on corresponding information logistics.

Information logistics aims to provide just-in-time information to targeted users and optimization of the information supply process, i.e. making the right information available at the right time and at the right point of location [5, 6]. Also in the context of maintenance of complex technical systems, e.g. intelligent transport systems, with long lifecycles the importance of appropriate information logistics is emphasised (see [16, 17, 18]). Here, it should be noted that the life of most services are much shorter than that of the system, which makes it beneficial to have a service-orientation and a high level of intelligence to adapt the services to new and emerging requirements.

Today, the establishment of efficient and effective information logistics is highly dependent on the utilisation of Information and Communication Technology (ICT). The development of ICT-based solutions should consider three essential aspects: architecture, infrastructure and content ontology [9]. The architecture of a solution involves the description of the solution's inherent elements, the interactions between the elements, their composition guided by patterns and constraints on those patterns [19,

20]. The infrastructure can be considered as the platform that aims to provide features for the production environment for a solution. The content refers to the any type of data and information, which are managed by the solution through the underlying infrastructure. The content is used to enable communication in terms of the transfer of messages through a dynamic provisioning of channels and medias for transmission [21, 22], see Figure 3.

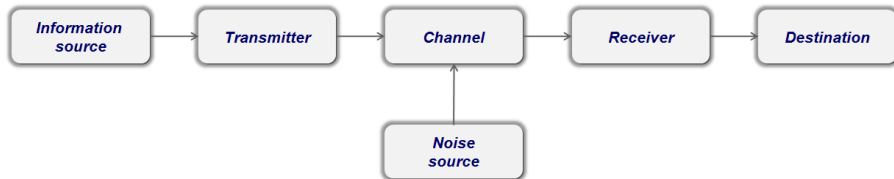

**Figure 3 – A model of communication, adapted from [22]**

As within eMaintenance, one approach to define a software architecture is based on a service-orientation. Service-Oriented Architecture (SOA) presents a vision of a world where resources are cleanly portioned and consistently represented [23]. SOA is gaining momentum worldwide by promising agility, mobility, interoperability, reuse and better alignment with business objectives [23, 24]. In the context of software architecture, SOA represents a model where business logic is de-composed into smaller elements that can be distributed [23]. One of the benefits of such elements is that they are autonomous and can be individually distributed [23, 24]. Another benefit is that these elements are unified by the term service, in order to reduce their dependency on underlying technology and emphasize their target, i.e. the business processes [23, 24]. Furthermore, the Organization for Advanced Standards for Information Society (OASIS) describes SOA as a collection of best practices, principles and patterns related to service-aware, enterprise-level, distributed computing [25]. SOA-related standardization efforts at OASIS focus on workflows, translation coordination, orchestration, collaboration, loose coupling, business process modelling and other concepts that support agile computing (OASIS, 2008). Hence, service-orientation might be considered as an architectural design philosophy that facilitates encapsulation of business logic in an artefact called service. The establishment of SOA-based solutions requires underlying infrastructure that supports a service-oriented approach.

Service-Oriented Infrastructure (SOI) can be considered as a set of technologies and tools that are required to meet needs and requirements when services, according to SOA, are developed, implemented and managed in a solution [23, 25, 26]. It can be concluded that SOA, with support of SOI, aims to facilitate integration of ICT-based service solutions. The integration of services in a solution enables information sharing, which in return results in efficiency and flexibility in the process of service delivery to the service consumer [27].

#### **4 SOME RELATED RESEARCH EFFORTS**

There are several ongoing research efforts that provide contributions that are relevant and can be utilised within the domain of intelligent transport services and systems. Some major contributions are provided by the participants in the collaboration centre named ProcessIT Innovations at Luleå University of Technology [28]. One of the

centre's latest research proposals aims to investigate new methodologies and technologies that support an efficient development of embedded lightweight mobile autonomous and real-time services for integration of service-oriented and process-oriented solutions [29]. This planned research combines scientific and disciplinary aspects and focuses on methodologies and technologies that address: formal tools for efficient real-time software design; extreme low-power lightweight embedded system; mobile and wireless communications to enable efficient enterprise networks; context-aware service middleware; value chain information security design; stakeholder driven services - Living labs; Multi-dimensional (area, amplitude, time and phase) data generation; sensor and data fusion; information logistics; context driven adaptation; model-based signal processing and control; and brain-inspired decision models, see Figure 4.

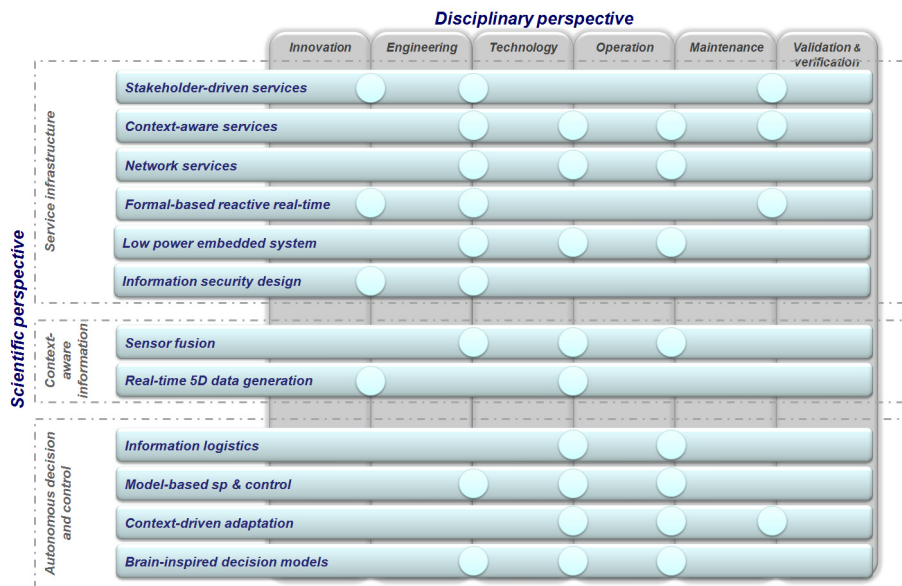

**Figure 4 – Relationship between scientific and disciplinary perspective in C-MARS, adapted from (C-MARS, 2009)**

In the context of intelligent transport services and systems, the contributions from this kind of research can be utilised to provide intelligent ICT-based information services in order to increase the overall systems performance and thereby achieve satisfaction of the service consumer.

## 5 DISCUSSION AND CONCLUSIONS

In Sweden there is a new Swedish Transport Agency, which is working to achieve good accessibility, high quality, secure and environmentally aware rail, air, sea and road transport. The agency has the overall responsibility for drawing up regulations and ensuring that authorities, companies, organisations and citizens abide by them. Therefore, there will be laws, regulations, development of transportation systems and services, as well as related research that will stimulate the integration of different modes of transportation.

Simultaneously, the Swedish Government has the ambition to create common principles for electronic information exchange between all government agencies. Hence, there will be an alignment of applied content format and ontology, which will provide an increased possibility to integrate different information sources useful for transportation purposes. In addition, there is a development of a national networked-based defence, which will be integrated with agencies for civil security. Hence, information infrastructures and information architectures on a national level will also be available. Together, these national ventures enforce a national network-based transportation system, which by use of new and innovative service-oriented ICT can provide intelligent transportation services at a national level.

At a national level, information exchange in the context of intelligent transport services and systems the information logistics is essential, since information logistics addresses the aspects of when to deliver; what to deliver; how to deliver; and where and why to deliver. The establishment of information logistics based on SOA and SOI increases the adaptivity of the inherent information services and enables the transportation system's capability to provide intelligent services that are context-aware and situation-aware by combining information available from different sources in order to meet the requirements of the transport system stakeholders.

#### **ACKNOWLEDGEMENT**

We would like to acknowledge the valuable intellectual support received from Anders O.E. Johansson, manager of Process IT Innovation at Luleå University of Technology.

#### **REFERENCES**

- [1] Swedish Transport Agency, "Swedish Transport Agency", Available at: <http://www.transportstyrelsen.se/en/>, 2008.
- [2] FMV, "Technological Prognosis 2005", Swedish Defence Material Administration, Stockholm, FMV, 2005. (In Swedish)
- [3] Svensson, P., "Peace is created through networks (Fred skapas genom nätverk)", *Protec*, Vol. 5, No.2, pp. 4-6, 2008a. (In Swedish)
- [4] Svensson, P., "Modern defence requires cooperation (Modernt försvar behöver samarbete)", *Protec*, Vol. 5, No.2, pp. 7, 2008b. (In Swedish)
- [5] Heuwinkel, K., Deiters, W., Königsmann, T. and Löffeler, T., "Information logistics and wearable computing", *Proceedings of the 23<sup>rd</sup> International Conference on Distributed Computing Systems*, 19-22 May 2003, pp. 283-288, 2003.
- [6] Haseloff, S., "Context Awareness in Information Logistics", Doctoral Thesis, Elektrotechnik und Informatik der Technischen Universität Berlin, Berlin, Germany, 2005.
- [7] Bangemann, T., Reboul, D., Szymanski, J., Thomesse, J-P and Zerhouni, N., "PROTEUS - An Integration Platform for Distributed Maintenance Systems", *Proceedings of the Intelligent Maintenance Systems (IMS) 2004 International Conference*, 15-17 July 2004, Arles, France, 2004.

- [8] Bangemann, T., Rebeuf, X., Reboul, D., Schulze, A. , Szymanski, J., Thomesse, J-P, Thron, M. and Zerhouni, N., "PROTEUS - Creating distributed maintenance systems through an integration platform", *Journal of Computers in Industry*, vol. 57, no. 6, pp. 539-551, 2006.
- [9] Karim, R., "A Service-Oriented Approach to eMaintenance of Complex Technical Systems", Doctoral Thesis, Luleå University of Technology. Sweden, 2008.
- [10] Kano, N., "Upsizing the organization by attractive quality creation", *Proceedings of the First world congress on Total Quality Management*. Sheffield, UK, 1995.
- [11] ISO/IEC, "15288: Systems engineering - System life cycle processes", International Organization for Standardization and International Electrotechnical Commission, Geneva, Switzerland, 2008.
- [12] IEV, "International Electrotechnical Vocabulary (IEV)", Available at: <http://www.electropedia.org/>, 2008 (accessed: 18 August 2008).
- [13] EB, "Encyclopedia Britannica (EB)", Available at: <http://www.britannica.com/>, 2009 (accessed: 13 May 2009).
- [14] RAND, "Network-Based Operations for the Swedish Defence Forces", RAND Corporation, Santa Monica, CA, USA, 2004.
- [15] IEC, "60300 (3-14): Dependability management - Part 3-14: Application guide - Maintenance and maintenance support", International Electrotechnical Commission, Geneva, Switzerland, 2004.
- [16] Tsang, A., "Strategic dimension of maintenance management", *Journal of Quality in Maintenance Engineering*, vol. 8, no. 1, pp. 07-39, 2002.
- [17] Blanchard, B.S., "Systems, Systems Engineering, Logistics and Product Support", *SOLEtech: Newsletter Published by SOLE - The International Society of Logistics*, vol. 4, no. 10, pp. 1-15, 2001.
- [18] Muller, A., Marquez, A. C. and Iung, B., "On the concept of eMaintenance: Review and current research", *Journal of Reliability Engineering and System Safety*, vol. 93, no. 8, pp. 1165-1187, 2008.
- [19] Sowa, J. F. and J. A. Zachman, "Extending and formalizing the framework for information systems architecture", *IBM Systems Journal*, vol. 31, no. 3, pp. 590-616, 1992.
- [20] Shaw, M. and Garlan, D., "Software Architecture: Perspective on Emerging Discipline", Prentice-Hall Inc., Upper Saddle River, New Jersey, USA, 1996.
- [21] Fiske, J., "Introduction to communication studies", Taylor & Francis Ltd, 1990.
- [22] Shannon, C. E., "A Mathematical Theory of Communication", ACM New York, NY, USA.

- [23] Erl, T., "Service-Oriented Architecture: Concepts, Technologies, and Design", Pearson Education Inc., Upper Saddle River, New Jersey, USA, 2006.
- [24] Pulier, E. and Taylor, H. Understanding, "Enterprise SOA", Manning Publication Co., Greenwich, 2006.
- [25] OASIS, "SOA. Organization for Advanced Standards for Information Society", available at: <<http://www.oasis-open.org/>>, 2008 (accessed: 18 August 2008).
- [26] Microsoft, "SOA", Microsoft, available at: <<http://www.microsoft.com>>, 2008 (accessed: 25 August 2008).
- [27] Erasala, Naveen; Yen, David C. and Rajkumar, T. M., "Enterprise application integration in the electronic commerce world", Computer Standards and Interfaces, vol. 25, no. 2, pp. 69-82, 2003.
- [28] ProcessIT, "ProcessIT Innovations", Available at: <http://www.processitinnovations.se/>, 2009 (accessed: 13 May 2009).
- [29] C-MARS, "C-MARS - Context aware mobile and autonomous real time service development and integration for process oriented enterprises", Luleå university of technology, diary no. 00825-2009, 2009.





## PAPER VI

### **eMaintenance - Information Driven Maintenance and Support**

**Candell, O.** and Karim, R. (2008). eMaintenance - Information Driven Maintenance and Support. Proceedings of the 18<sup>th</sup> International Conference on Flexible Automation and Intelligent Manufacturing (FAIM 2008), 30 June 2008, Skövde, Sweden.



# eMaintenance - Information Driven Maintenance and Support

Olov Candell<sup>1\*</sup> and Ramin Karim<sup>2</sup>

<sup>1</sup>Aircraft Services Division  
Saab Aerotech  
Linköping, Sweden

<sup>2</sup>Division of Operation & Maintenance Engineering  
Luleå University of Technology  
Luleå, Sweden

## ABSTRACT

*Today's providers of maintenance and in-service support related to modern aircraft are facing major challenges. A central problem with maintenance and support of aircraft and other complex technical systems is to manage the ever-increasing information flow and system complexity. Both military and commercial operators need to reduce downtime and one way to do this is to speed up the turnaround time for scheduled and unscheduled maintenance, or even better, to reduce the need thereof by implementing condition based maintenance. In order to implement these improved support solutions in a global support environment, eMaintenance is seen as one important building block. eMaintenance includes monitoring, collection, recording and distribution of real-time system health data, maintenance generated data as well as other decision and performance support to all stakeholders independent of organization or geographical location, 24 hours a day, 7 days a week (24/7). eMaintenance has the potential to improve the management and performance of activities related to the maintenance process, and thereby improve the dependability, safety and life cycle cost of critical systems. This is realized through the application of Information & Communication Technology (ICT) throughout the maintenance and support processes, thus integrating built-in tests, external tests at different maintenance echelons, technical information, diagnostics, prognostics and other sources of support information. The purpose of this paper is to present some results from a joint academic and aerospace industry research project, describing requirements and expectations that are important in a global support environment, and also to propose some central components in an eMaintenance framework that integrates maintenance and ICT perspectives.*

## 1. INTRODUCTION

Aircraft manufacturers, as well as maintenance and in-service support providers, are experiencing ever-increasing customer requirements to increase dependability and decrease life support cost. A central problem for the industry is to manage the rapidly increasing information flow that follows the development of more complex and technologically advanced aircraft systems. Customers are also demanding improved system availability, cost effectiveness, operational flexibility and tailored worldwide support 24 hours a day, 7 days a week (24/7). This changing business environment requires new and innovative improvements of support products and services to satisfy the needs of customer and end user.

Maintenance and support concepts for modern complex technical systems, such as civil airliners and military combat aircraft, can be described as focussing on optimizing two fundamental and interdependent elements. The first element is the way in which the design of the aircraft (i.e. the system-of-interest) is influenced to maximize its inherent availability within available Life Cycle Cost (LCC) requirements. This ensures that the aircraft will have high reliability and maintainability in relevant operational profiles and support environments. The second element concerns the design of the maintenance and support system, which provides necessary support during the operation and maintenance phases of the system-of-interest. The maintenance and support system is an enabling system, i.e. a system that complements a system-of-interest during its life cycle stages, but does not necessarily contribute directly to its function during operation [11]. An enabling system provides functions and services to users and other stakeholders to ensure the proper and efficient function of the system-of-interest. [6]

On an operational level, end-users and managers utilizing the support and maintenance system of a modern aircraft are confronted with a multitude of computerized functions and information technology solutions. However, today there is little or no integration of functions and services related to the maintenance and support system, such

---

\* Corresponding author: Tel.: +46 (0)13 181739; Fax: +46 (0)13 183050; E-mail: olov.candell@saabgroup.com

as technical information (publications), maintenance programmes, maintenance plans, job cards, fault localization support, amendment services, health monitoring, and operational feedback. [4][7]

At the same time, producers and suppliers of maintenance products and customer support services are facing escalating challenges trying to sustain high quality and increase service levels for increasingly complex technical systems in an environment characterized by multiple products, suppliers and customers with increasingly stringent requirements. Hence, both customers and suppliers are facing increased complexity levels regarding information related to configuration control and change management for both the aircraft and its enabling system. This high complexity level of information management will hamper the operational effectiveness and drive LCC.

Therefore, suppliers need to change methodologies and processes for information management to be both more customer-focused and more efficient for internal development and sustainability. New concepts for the application of Information & Communication Technology (ICT) need to address information quality, lead time, accessibility 24/7, usability and an overall reduction of cost for information management related to maintenance and support. Capability also needs to be developed to enable more agile and efficient use of new maintenance and support functions integrated in the aircraft, exploitation of operational feedback, as well as rapid supplier adaptation to continuously changing customer specific requirements on both hardware and software products as well as services.

## 2. SCOPE

This paper focuses on a concept for ICT-based products and services for maintenance and support to modern aircraft operation. However, it is believed to be extensively applicable to similar challenges regarding maintenance and support of other complex technical systems, e.g. within the transport, process and power industries, as well as telecom and health care. The paper presents requirements and needs regarding the mentioned products and services that are important for both suppliers and customers (operators) of modern aircraft systems in a global support environment and proposes some central components of an information management concept, called eMaintenance Management Framework (eMMF), that integrates maintenance and ICT perspectives to address the challenges presented above.

The discussion of the central characteristics of system-of-interest (e.g. aircraft) and enabling systems (e.g. a maintenance and support system external to the aircraft) uses nomenclature based on established and agreed international standards [5] [6]. 'Availability' is used as a general term referring to availability performance and its influencing factors: reliability performance (the way the aircraft is designed to eliminate the need of maintenance, i.e. reducing or eliminating the probability of loss of required functions); maintainability performance (the way the aircraft is designed to facilitate maintenance, i.e. to retain or restore the aircraft's required functions); as well as maintenance support performance (effectiveness and efficiency of the maintenance and support organization).

## 3. MAINTENANCE WITHIN AVIATION

Experience from maintenance and support system development and real life operations [14], combined with expectations for future scenarios, stress the importance of supporting the operational capability and competitiveness through high availability of aircraft (but also other complex technical systems, such as, maritime and ground systems). Increasing civil requirements on mobility and availability, and military operations from provisional bases combined with rapidly shifting conditions, increase the importance of information and decision support to personnel that service and maintain systems in operation.

The aircraft design, as well as the maintenance and support system, needs to be very structured and controlled, meeting requirements with the overall objective of maximizing the total system capability at the lowest LCC, see Figure 1. The design of the maintenance and support system itself also needs to take into account other requirements, such as operators' requests to consider re-use of existing resources and capabilities (e.g. facilities, manpower, competencies, ICT infrastructure and standards) and future requirements, operational or product development requirements, as well as desired levels of self-support.



Figure 1: Important requirements related to aircraft effectiveness

New technology and innovation also drive development and create new needs. A military example is the so-called fourth generation combat aircraft, e.g. Dassault Rafale, Eurofighter Typhoon and Saab Gripen. These are system aircraft with a digital infrastructure and fully integrated computer systems that utilize a common database through standardized interfaces [1] [10]. The building principle of a system-of-systems supplies an immense potential for functional development, but also an extremely complex aircraft system [14]. The civilian equivalents, such as the Boeing 787 Dreamliner and Airbus A350, have focused on ICT as a central component for more efficient maintenance and support solutions. A central part of this aircraft technology development is advanced Built-in Test (BIT) systems. The aircraft BIT is constantly being developed to improve safety, maintainability, testability and supportability of the aircraft as well as to provide health information. This extended access to qualified data from operation and maintenance provides the technical foundation for condition monitoring, extensive data recording, test, diagnostics, prognostics and decision support for condition-based operation and maintenance [14]. These technology trends, together with the pervasiveness of ICT in the maintenance system and support processes, are also key enabling factors for implementation of remote support services accessible world wide and 24/7. Nevertheless, the BIT is itself a development that adds further requirements and puts strain on supporting ICT frameworks and information management processes.

Thus information management and new ICT solutions has become a central aspect and common denominator for many of the new challenges regarding system complexity, configuration control, change management and applicability of product information, both for the systems-of-interests and their related support system products. To meet the increasing demand on availability and to cut costs, maintenance and support actors are becoming more and more dependant on ICT to provide timely and accurate information. Efficient ICT solutions have rapidly risen as a key driver for good decision-making and effective operations. One example of an area with great improvement potential is technical publications. A large proportion of the information support used by maintainers in the aerospace industry is still paper documents, or ‘paper-on-screen’ solutions (e.g. paper publication suits published as PDF). All this, despite the fact that new aircraft complexity, integrated digital systems and air-to-ground real-time communication tools make paper-based approaches increasingly inadequate. This generates unnecessary cost for the simple reason that maintainers often lack products and services for information support that are adapted to specific roles and situations, and therefore cannot work as efficiently as possible. [3] [4].

With reference to the problem and solution domains presented above, the concept of eMaintenance presented in this paper can be defined as a structured and coherent application of ICT in the design of the maintenance and support system, coordinated with technical solutions in the aircraft system. The main goal is to create a more efficient maintenance and support process by optimization of an eMaintenance framework as a part of the enabling systems, and thereby improve overall system effectiveness,

To secure the performance of an aircraft at a reasonable cost, it is vital that the design of maintenance and product support concepts is done correctly right from the design phase [2] [11]. The character, scope and allocation of the support needed, must also be influenced by the customers’ competencies, as well as the environment for the operation, but also organizational and cultural issues [11] [13]. The overall maintenance process needs to be taken into consideration, including its sub-processes for management, support planning, preparation, execution, assessment and improvement (see Figure 2). Hence, the requirements analysis must consider a multitude of aspects, facts, needs and properties of the technical system, customer requirements and the context for operation and

maintenance for the given system, supplier requirements and other stakeholders, as well as environment and legislation.

Yet another aspect is the fact that traditionally the civil and defence aerospace industries have built and sold systems to operators. Today, this approach is changing and the industry also has to provide services that traditionally have been carried out by the operators or other third party suppliers. The highest degree of commitment is needed when delivering total care, or functional products, where the customers are offered availability performance at a fixed price. One example of this is the requirement of ‘Maintenance Free Operating Period’ (MFOP). These are market driven requirements on an eMaintenance solution, which introduce additional stakeholder perspectives. [3]

#### 4. EMAINTENANCE REQUIREMENTS

With reference to the material presented above, the development of products and services integrated with ICT in an eMaintenance solution for support to operation and maintenance of complex systems, needs to address a number of central requirements such as:

- integration of the system-of-interest and its enabling system, to exploit technological development of modern aircraft and ICT in efficient solutions for global maintenance and support 24/7,
- Facilitation of configuration control, change management and directive information applicability for both the system-of-interest and products and services included in the enabling system,
- Integration of role and situation adapted products and services for information and performance support with high accessibility and usability,
- coordination and integration of consumption and production of information at different phases of the maintenance process
- coordination and integration of tests, diagnostics and prognostics for condition-based operation and support at different maintenance echelons
- support to performance-based contracts and functional sales (e.g. power-by-the-hour)
- adherence to international (information) standards.

eMaintenance needs to facilitate support to operators’ and other stakeholders’ work through information and performance support to the overall maintenance process related to modern aircraft, including ground support equipment and training devices. eMaintenance also needs to provide a framework and processes for managing product data and information, maintenance and support information as well as feedback of data and information from operational and maintenance activities. This spectrum of requirements built on industrial and operator experience, drives the approach that the improvement of the operative performance and effectiveness of maintenance and support through the introduction of eMaintenance, need to target all phases of the maintenance process (see Figure 2).

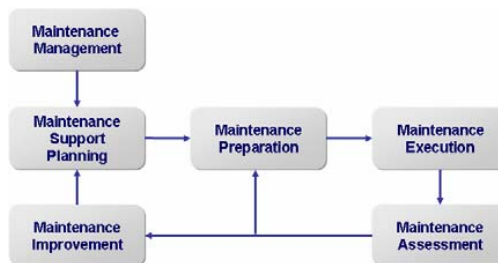

Figure 2: Sub-processes of an overall maintenance process, adapted from [5]

In order for the aerospace industry to manage the risks associated with these new, diversified and enhanced solutions in a global support environment, a wide collection of heterogeneous information sources need to be funnelled and made available for the right user, in the right format, in the right place, at the right time. In the past, the information flow has been quite rigid and inflexible between a rather small number of stakeholders. However, in

the future the exchange of information is required to reflect closer working relationships and a more dynamic, global support environment and deliver efficient and tailored support for decision-making to stakeholders spanning from Original Equipment Manufacturers (OEMs), sub-system suppliers, through system integrators on to operators, maintainers and support providers.

Another important requirement that follows on from the character of the challenges presented above is that information management concepts and application of new ICT solutions within the aerospace industry, to a growing extent need to be both based on, and capitalize on international standards for structured product data sharing. Central among these standards are Product Life Cycle Support (PLCS) [12], Sharable Content Object Reference Model (SCORM) [15] and the ASD (AeroSpace and Defense Industries Association of Europe) specifications suite of standards for Integrated Logistic Support (ILS); S1000D, S2000M and the emerging S3000L and S4000M.

As discussed above, the overall maintenance process involves sub-processes for management, support planning, preparation, execution, assessment, and improvement, see Figure 2. These sub-processes consist of different sets of activities, which are interrelated and adapted to fulfil requirements from different stakeholders. Stakeholders within the maintenance process consume and produce information when performing different activities. For example, during maintenance execution, a maintenance technician receives a work order that requires a maintenance action, and after the performed action the technician reports the outcome. The information from the execution process can further be aggregated to a context in the assessment process. As illustrated in Figure 3, the maintenance technician needs to access various types and formats of information through different information sources when conducting a maintenance action.

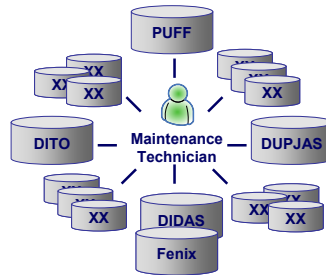

Figure 3: Illustrating the information system needs of a maintenance technician

Hence, one of the main objectives of establishing a platform for eMaintenance is to provide a supporting ICT environment that improves the performance of the maintenance process by providing seamless and integrated services for sharing content. It is commonly accepted that data collection and distribution is a major issue in the maintenance process and a cornerstone in the area of eMaintenance [7]. It is also accepted that there is a need to be able to convert data to information, and based on this information to generate knowledge valuable for decision-making. In order to make the right decisions, there is a need to be able to access and manage the right knowledge. Since knowledge, a term which basically refers to what is known, is not only a summarization of known raw data through information interpretation, but also implies other artefacts, such as documentation and experiences, the authors believe that the focus should be on the content and the content sharing in the maintenance process rather than on data and data processing. [8]

ICT is one of the main prerequisites, not only to improve the maintenance process for complex systems with long lifecycles, but also to reduce risks, and contribute to a more efficient business process. The utilization of ICT facilitates content sharing and knowledge management within the processes of the maintenance process, coordinates the maintenance process with other processes (e.g. operation and modification processes) and links it to strategic business objectives and external stakeholder requirements. In order to offer an effective and efficient eMaintenance solution, some essential requirements need to be fulfilled by means of an eMaintenance Management Framework.

As shown in Figures 5 and 6 the eMaintenance Management Framework (eMMF) is the institution of a framework, a meta-level model through which a range of concepts, models, techniques and methodologies can be clarified and/or integrated. The main aim of an eMMF is to facilitate maintenance. The framework consists of two parts: the eMaintenance Management Model (eMMM) and the eMaintenance Platform (eMP). The eMMM is a package of roles, processes and repositories required for managing the eMP. The eMP is a Service-Oriented Architecture (SOA) application, created to provide its stakeholders with tailored information for making decisions on the choice of appropriate maintenance activities.

The eMP is divided into three levels: Specification, Design, and Implementation (see Figure 6). The Specification level contains all the information necessary for conducting industrial maintenance. It describes the identified requirements, which are realized in various ways using notations such as text and models. The Design level identifies design components that are needed to fulfil the requirements specified in the Specification level. This level is realized as service components. Finally, the Implementation level materializes the service components specified in the Design level into the web services and business processes orchestrated for the needs. Each level consists of one or several groups of components. All components in the specification level provide a platform for creating other components in the Specification level or they get directly realized on the Design and/or Implementation levels. [9]

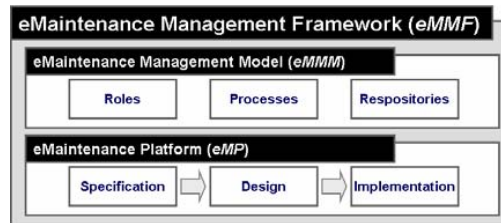

Figure 5: Illustrating the substances in eMMF [9]

eMP provides artefacts for supporting the maintenance process, e.g. situation adapted information and services for performance support [4][7]. Further, we have explored how SOA can be exploited in eMP. Hence, our conclusion is that the eMP can be utilized to implement an eMaintenance platform in organizations that provide maintenance of complex technical systems. We believe that eMP also is applicable in any organization providing maintenance, since it has been based on a generic overall maintenance process.

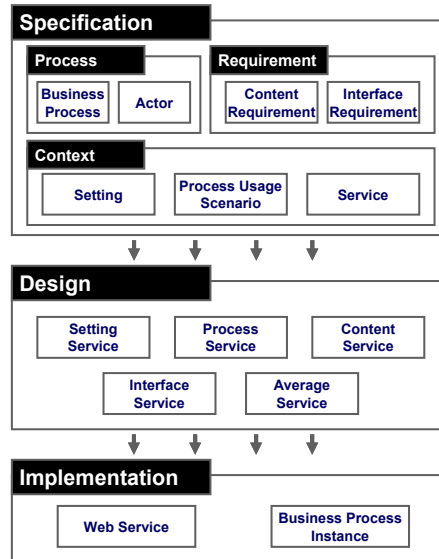

Figure 6: Illustrating the substances in eMP [9]

The Specification level contains all the information necessary for conducting industrial maintenance. It consists of three components: Process, Requirements and Context. The Process component lists and describes the business processes and actors involved in them. It consists of two parts: Business Process and Actor. The Context component lists and describes various backgrounds and their interrelated conditions in which maintenance activities take place. It consists of three components: Setting, Process Usage Scenario, and Service. The Requirement component lists and describes all the functional and non-functional requirements on the information needed for a specific maintenance task and the interface through which this information should be presented. It consists of two components: Content Requirement and Interface Requirement.



The Design level transforms most of the specification components into SOA components. The role of the Setting Service component is to design choreography for a certain set of services. The role of the Process Service component is to design a composition of miscellaneous services orchestrated for serving a particular process. The role of the Content Service component is to design services that implement logic for interaction with different data sources, such as existing systems or legacy systems. The role of the Interface Service component is to design services that handle/manage/wrap/adapt interface to other devices such as a portable handheld computer. The Implementation level materializes the SOA components into the web services and business processes orchestrated for the needs at hand. The Web Service component implements the SOA components in the design level as Web Services. We use Web Services, since they provide a generic interface for encapsulating logics and can be utilized as an intermediate layer to access legacy systems. The Business Process component corresponds to business processes as orchestrated for the needs at hand and delivered to the service consumer. In the context of eMaintenance, there is a need for both predetermined business processes and reactive business processes.

## 5. CONCLUSIONS

The positive impact of eMaintenance is to be expected on two levels. On one, the ‘maintenance micro-level’, it will serve as a performance support facilitating hands-on execution of maintenance tasks by technicians, mechanics and support engineers, by providing a reduced number of interfaces to information sources, improved fault diagnosis, knowledge sharing and automated or facilitated procedures for technical administration. On the higher ‘maintenance macro-level’, eMaintenance will support managerial maintenance planning, preparation and assessment, enabling information driven maintenance and support processes, and fleet-efficiency, e.g. aircraft maintenance programme evaluation, elimination of redundant information and operational monitoring.

There is also the challenge of going from a product-oriented to a service-oriented business strategy. Product-oriented strategy relies on a transaction/exchange marketing, while service-oriented emphasizes the relation between provider and customer. A service-oriented business strategy also demands the harmonization of support processes, such as the maintenance process, to the business’s core process. The business’s core process ought to be adaptable to the changes in the customers’ value-generating process, and the business’s supporting processes need to be adaptable to the core process.

Since an eMaintenance platform’s major purpose is to support the maintenance process, the components of the platform need to be considered from a service-oriented perspective in order to increase its adaptability to the different parts of the maintenance and support process in different organizations. Hence, eMaintenance can be considered as a platform for smart content sharing between information provider and information consumer. We use the term-pair provider/consumer to emphasize that the ICT support to the maintenance process should adopt a process-centric approach, supporting efficient maintenance and support solutions. In a supplier/customer approach, the definition of the organizational boundary is important, which is not necessarily an issue of importance for delivery maintenance ICT services.

The maintenance process has to interact with a number of correlated processes in an enterprise, e.g. business, operation, information, support, and logistics. Hence, a service-oriented eMaintenance platform should provide services that can be incorporated and orchestrated to flow of these processes. While the requirements on the maintenance process vary over time, the architecture of eMaintenance should be constructed to provide applicability and effectiveness.

With applicability and effectiveness as the two major requirements, it is clear that a Service-Oriented Architecture (SOA) approach is a prerequisite for being able to design an ICT architecture which will provide applicable and effective eMaintenance services. Furthermore it should be noted that a Service-Oriented Infrastructure (SOI) is a prerequisite for implementing SOA. , It is important to be aware that Web Services (WS), and their related technologies, e.g. WS-BPEL, WS-Transaction and WS-Coordination, are not synonymous with SOA: SOA is a way of thinking that approaches the architectural issues and WS is technology that is designed to facilitate the implementation of SOA.

We believe, based on our study of the effects of eMaintenance, that the eMaintenance platform, mainly through its improvement of the different parts of the maintenance process, impacts on the dependability, safety, and life support costs of critical systems. Hence, our conclusion is that an eMaintenance platform (eMP) structured, designed, and implemented from a service-oriented perspective with focus on the business process, increases the ability to fulfil the requirements such as context-awareness, situation-awareness, seamless information integration between processes (e.g. operation and maintenance), improved knowledge-sharing, flexibility, extensibility and

cost-reduction. Further, we can conclude that SOA as an approach and Web Service as a technology can be utilized to implement service-oriented maintenance services. Loosely connected maintenance services can easily be re-composed and orchestrated to the new process, situation and context to better fulfil different stakeholders' requirements.

## ACKNOWLEDGEMENTS

The work presented in this paper has been carried out at the Division of Operations & Maintenance Engineering, Luleå University of Technology and Saab Aerotech, Linköping, Sweden. The authors would like to acknowledge the financial support of the National Aeronautics Research Programme, NFFP4 and Aircraft Services Division, Saab Aerotech as well as the valuable knowledge support from the Swedish Air Wing F21 in Luleå.

## REFERENCES

- [1] Ahlgren, J., Christofferson, L., Jansson, L. & Linnér, A., *Faktaboken om Gripen. (4th ed.)*, Industrigruppen JAS, 1998. (In Swedish).
- [2] Blanchard, B. S. , *Logistics engineering and management. (4th ed.)*, Englewood Cliffs, NJ: Prentice Hall, 1992.
- [3] Candell, O. and Söderholm, P., *A customer and product support perspective of eMaintenance. 19th International Congress on Condition Monitoring and Diagnostics Engineering Management (COMADEM)*, pp. 243-252, Luleå, Sweden, 2006.
- [4] Candell, O., *Development of User Information Products for Complex Technical Systems*, licentiate thesis, Luleå University of Technology, Luleå, Sweden, 2004.
- [5] IEC 60300-3-14: *Dependability management, Part 3-14: Application guide; Maintenance and maintenance support*. International Electrotechnical Commission (IEC), Geneva, Switzerland.
- [6] ISO/IEC-15288, "Systems engineering – System life cycle processes", (International Organization for Standardization, Geneva. International Electrotechnical Commission, Geneva., 2003), 2003.
- [7] Saab, internal document. Candell, O., *Maintenance WorkStation – MWS, Final Report*, 2007.
- [8] Karim, R and Söderholm, P., "Application of Information and Communication Technology for Remote Support Services: Transferring experiences from an e-Health Solution in Sweden", Submitted for publication, 2007.
- [9] Karim, R., Kajko-Mattsson, M. and Söderholm, "Exploitation of SOA within eMaintenance", 2008.
- [10] Lorell, M., Raymer, D. P., Kennedy, M. & Levaux, H., *Grey threat : assessing the next-generation European fighters*. Santa Monica, Ca.: Rand Corporation, 1995.
- [11] Markeset, T. and Kumar, U., *Design and development of product support and maintenance concepts for industrial systems*. *Journal of Quality in Maintenance Engineering*, 9, (4), 376-392, 2003.
- [12] OASIS, "OASIS Product Life Cycle Support (PLCS) TC". Available <[http://www.oasis-open.org/committees/tc\\_home.php?wg\\_abbrev=plcs](http://www.oasis-open.org/committees/tc_home.php?wg_abbrev=plcs)>, 2006.
- [13] Pinet, J., *Human factors: A humanist and ethical approach to aeronautics. Part I/III*. *Air & Space Europe*, 2, (1), 2000.
- [14] Sandberg, A. and Strömberg, U., *Gripen: with focus on availability performance and life support cost over the product life cycle*. *Journal of Quality in Maintenance*, 5, 325-334., 1999.
- [15] SCORM, "Sharable Content Object Reference Model", Available <http://www.w3.org/2004/04/webapps-cdfws/papers/SCORM.htm>, 2004.



